

• 15R0102B200 •

# SINUS PENTA

MULTIFUNCTION AC DRIVE

## USER MANUAL -Programming Guide-

Issued on 16/03/15

R. 00

Software Version 4.04x

**English**

- This manual is integrant and essential to the product. Carefully read the instructions contained herein as they provide important hints for use and maintenance safety.
- This device is to be used only for the purposes it has been designed to. Other uses should be considered improper and dangerous. The manufacturer is not responsible for possible damages caused by improper, erroneous and irrational uses.
- **Elettronica Santerno is responsible for the device in its original setting.**
- Any changes to the structure or operating cycle of the device must be performed or authorized by the Engineering Department of Elettronica Santerno.
- Elettronica Santerno assumes no responsibility for the consequences resulting by the use of non-original spare-parts.
- Elettronica Santerno reserves the right to make any technical changes to this manual and to the device without prior notice. If printing errors or similar are detected, the corrections will be included in the new releases of the manual.
- The information contained herein is the property of Elettronica Santerno and cannot be reproduced. Elettronica Santerno enforces its rights on the drawings and catalogues according to the law.



Elettronica Santerno S.p.A.  
Via della Concia, 7 – 40023 Castel Guelfo (BO)  
Tel. +39 0542 489711 – Fax +39 0542 489722  
[santerno.com](http://santerno.com) [info@santerno.com](mailto:info@santerno.com)

## REVISION INDEX

**Modifications in respect to Programming Guide 15R0102B1, release R.08, SW version 1.69x issued on 27/03/2013**

The following subjects covered in this Programming Guide R.00 (SW version 4.04x) have been added, changed or suppressed in respect to the previous version R.08 (SW version 1.69x).

### **New VTC Control**

The VTC control has been completely changed. Changes are as follows:

The following menus have been added:

VTC REGULATORS MENU

VTC DEAD TIME COMPENSATION MENU

Encoder Measures Menu

First Startup Procedure changed for "VTC" Control Algorithm

The following parameters have been added:

**P153** VTC Speed Error Filter Time Constant

**C213a** Proportional Gain Torque Reduction for Overvoltage

**C213b** Integral Gain Torque Reduction for Overvoltage

**C213c** Voltage Reference for Torque Reduction (%V Unlock)

**C213d** Flux Reduction for Vdc Torque Reduction Activation

**C264a** Fan Startup Logics

The following selection options have been added:

D68: Accelerating

Motor accelerating

D69: Decelerating

Motor decelerating

in Table 47

### **SAFETY ENABLE**

The new control board is provided with two separate ENABLE terminals (**ENABLE-A** and **ENABLE-B**) as safety redundancy terminals. Therefore, the function that can be allocated to the input digitals, named **ENABLE-S** in the previous versions of this manual (parameter **C152**) has been renamed as **ENABLE-SW** to avoid confusion with the safety hardware inputs.

### **Additional Changes**

The description of the Read/Write Words for all parameters in the Sinus Penta has been added to the FIELD BUS CONFIGURATION MENU.

All references to the Multipump application have been suppressed and replaced with IRIS BLUE – Programming Guide.

**Modifications in respect to Programming Guide 15R0102B1, release R.08, SW version SW 4.02x issued on 20/05/2014**

The following subjects covered in this Programming Guide R.00 (SW version 4.04x) have been added, changed or suppressed in respect to the previous version (SW version 4.02x).

First Startup Procedure changed for "VTC" Control Algorithm.

The following parameters/measurements have been added:

**M051a** RMS Input from AIN1 and AIN2  
**P269b** ESC Key to Restore Previous Value  
**C035a/ C078a/ C121a** Boost0 Application Frequency  
**C152** Enable-SW Input  
**C184a** External Torque Limit Disable in Fluxing Mode  
**C250** MDI for Speed Search Enable  
**C303** Brake Activation during Tracking Error  
**C264a** Fan Startup Logics

The following selection options have been added:

2: Active, except for torque limitation in **C194** Speed Alarm Enable  
 9: Vout in **C285 (C286,C287)** Selection of PID Reference n.1(2, 3)  
 13: Vout Measured in **C288 (C289,C290)** Selection of PID Feedback n.1(2, 3).

The following alarms have been added:

**A129** No Output Phase  
**A140** Torque Off not Safe

The following selection option has been added:

65: Actual current Iv Output Iv Current  
 in Table 34

The following selection options have been added:

|                         |  |
|-------------------------|--|
| D64: NTC Fault          | NTC Fault (heatsink temperature measurement)   |
| D65: Cumulative Warning | Logic OR in W40 (FAN FAULT), W50 (NTC FAULT), W48 (OT TIME OVER), W49 (ST TIME OVER) |
| D66: Dec to Stop        | Deceleration due to START opening or STOP activation                                 |
| D68: Accelerating       | Motor accelerating   |
| D69: Decelerating       | Motor decelerating   |
| A129: PID2 REF          | PID2 reference   |
| A130: PID2 RMP          | PID2 reference after ramps   |
| A131: PID2 Fbk          | PID2 feedback  |
| A132: PID2 Err          | Error between PID2 reference and feedback  |
| A133: PID2 Out          | PID2 output  |
| A134: Torque Demand %   | Torque demand (percentage)   |
| A135: Actual Current Iv | Iv output current  |

in Table 47

The heading

BRAKING MODULE

has been changed to

BRAKING AND RAMP EXTENSION MENU

The description of the Read/Write Words for all parameters in the Sinus Penta has been added to the FIELD BUS CONFIGURATION MENU.

All references to the Multipump application have been suppressed and replaced with IRIS BLUE – Programming Guide.

Section

Example of Compensation of Voltage Drop in a Filter  
 has been added

## USER MANUALS MENTIONED IN THIS PROGRAMMING GUIDE

The following User Manuals from Elettronica Santerno are mentioned throughout this Programming Guide:

- **15P0102B1** SINUS PENTA - Installation Guide
- **15W0102B300** SINUS PENTA - Safe Torque Off Function - Application Manual
- **15G0010B1** PROFIdrive COMMUNICATIONS BOARD – Installation and Programming Guide
- **15G0851B100** DATA LOGGER ES851 – Programming Guide
- **16B0901B1** Remote Drive DRIVE REMOTE CONTROL – User Manual
- **15R1102B100** IRIS BLUE – Programming Guide

## 0. TABLE OF CONTENTS

### 0.1. Chapters

|  |    |
|--|----|
| REVISION INDEX.....  | 2  |
| 0. TABLE OF CONTENTS.....  | 5  |
| 0.1. Chapters.....   | 5  |
| 0.2. Figures.....  | 10 |
| 0.3. Tables.....   | 11 |
| 0.4. Scope of this Manual.....   | 14 |
| 0.5. How to Use this Manual.....   | 14 |
| 0.5.1. Overview.....   | 14 |
| 0.5.2. Special Applications Dedicated to Sinus Penta Drives.....         | 14 |
| 0.5.3. Menus and Submenus.....   | 15 |
| 0.5.4. Alarms and Warnings.....  | 17 |
| 1. USING THE DISPLAY/KEYPAD UNIT.....                                    | 18 |
| 1.1. Overview.....   | 18 |
| 1.2. Menu Tree.....  | 19 |
| 1.3. Navigation.....   | 21 |
| 1.4. Parameter Modification.....   | 22 |
| 1.5. Programming the Root Page.....                                      | 22 |
| 1.6. Using the MENU Key.....   | 23 |
| 1.7. ESC Key.....  | 24 |
| 1.8. RESET Key (Alarm and Control Board Reset).....                      | 25 |
| 1.9. TX/RX Key (Download/Upload from/to the Keypad).....                 | 25 |
| 1.10. LOC/REM Key (Keypad Pages).....                                    | 26 |
| 1.11. SAVE/ENTER Key.....  | 26 |
| 1.12. Indicator LEDs on the Display/Keypad.....                          | 27 |
| 2. DESCRIPTION OF INPUT AND OUTPUT SIGNALS.....                          | 28 |
| 3. REFERENCES AND FEEDBACKS.....   | 29 |
| 3.1. Main Speed/Torque Reference.....                                    | 29 |
| 3.2. Speed/Torque Limit Reference.....                                   | 29 |
| 3.3. PID Reference.....  | 29 |
| 3.4. PID Feedback Reference.....   | 29 |
| 4. PROGRAMMABLE FUNCTIONS.....   | 30 |
| 4.1. Multimotor.....   | 30 |
| 4.2. Voltage/Frequency Pattern.....                                      | 30 |
| 4.3. Slip Compensation.....  | 30 |
| 4.4. Speed Searching.....  | 30 |
| 4.5. Controlled Stop in Case of Power Failure (Power Down).....          | 30 |
| 4.6. DC Braking.....   | 30 |
| 4.7. Motor Thermal Protection.....                                       | 30 |
| 4.8. Prohibit Speeds.....  | 31 |
| 4.9. Digital PID Regulator.....  | 31 |
| 4.10. Bridge Crane Application.....                                      | 31 |
| 4.11. Setting Two Alternative Command Sources and Reference Sources..... | 31 |
| 4.12. Fire Mode.....   | 32 |
| 5. PROGRAMMING EXAMPLES.....   | 33 |
| 5.1. Overview.....   | 33 |
| 5.2. Programming a Reference.....  | 33 |
| 5.3. Configuring the External Torque Limit.....                          | 37 |
| 5.4. Configuring the Feedback from Incremental Encoder.....              | 38 |
| 5.5. Configuring a Reference from Incremental Encoder.....               | 39 |
| 6. START-UP MENU.....  | 40 |
| 6.1. Overview.....   | 40 |
| 7. FIRST STARTUP.....  | 42 |
| 7.1. "IFD" Control Algorithm.....  | 42 |
| 7.2. "VTC" Control Algorithm.....  | 44 |
| 7.3. "FOC" Motor Control.....  | 47 |
| 8. MEASURES MENU.....  | 50 |
| 8.1. Overview.....   | 50 |
| 8.2. Motor Measures Menu.....  | 51 |
| 8.3. PID Regulator Menu.....   | 56 |
| 8.4. Digital Inputs Menu.....  | 60 |
| 8.5. References Menu.....  | 62 |

|         |  |     |
|---------|--|-----|
| 8.6.    | Outputs Menu .....   | 66  |
| 8.7.    | Temperature Measures from PT100 Menu .....                 | 68  |
| 8.8.    | Autodiagnosics Menu .....                                  | 69  |
| 8.9.    | Data Logger Measures Menu .....                            | 71  |
| 8.10.   | Encoder Measures Menu .....                                | 73  |
| 8.11.   | Digital Input Settings Menu .....                          | 74  |
| 8.12.   | Fault List Menu .....                                      | 75  |
| 8.13.   | Power Off List Menu .....                                  | 77  |
| 9.      | PRODUCT MENU .....   | 79  |
| 9.1.    | Overview .....   | 79  |
| 9.2.    | List of Parameter P263 and Fire Mode Enable Password ..... | 79  |
| 10.     | PASSWORD AND USER LEVEL MENU .....                         | 83  |
| 10.1.   | Overview .....   | 83  |
| 10.2.   | List of Parameters P000 to P003 .....                      | 83  |
| 11.     | DISPLAY/KEYPAD MENU .....                                  | 85  |
| 11.1.   | Overview .....   | 85  |
| 11.2.   | Root Page .....  | 85  |
| 11.3.   | Keypad Page and Local Mode .....                           | 86  |
| 11.4.   | List of Parameters P264 to P269b .....                     | 87  |
| 12.     | RAMPS MENU .....   | 93  |
| 12.1.   | Overview .....   | 93  |
| 12.1.1. | Description of the Speed Ramps .....                       | 93  |
| 12.1.2. | Description of the Torque Ramps .....                      | 96  |
| 12.2.   | List of Parameters P009 to P033 .....                      | 97  |
| 13.     | INPUTS FOR REFERENCES MENU .....                           | 105 |
| 13.1.   | Processing Speed/Torque References .....                   | 105 |
| 13.2.   | Scaling Analog Inputs REF, AIN1, AIN2 .....                | 108 |
| 13.3.   | List of Parameters P050 to P074a .....                     | 112 |
| 14.     | MULTISPEED MENU .....                                      | 124 |
| 14.1.   | Overview .....   | 124 |
| 14.2.   | List of Parameters P080 to P100 .....                      | 124 |
| 15.     | PID MULTIREFERENCES MENU .....                             | 127 |
| 15.1.   | Overview .....   | 127 |
| 15.2.   | List of Parameters P080a to P099a .....                    | 128 |
| 16.     | PROHIBIT SPEED MENU .....                                  | 130 |
| 16.1.   | Overview .....   | 130 |
| 16.2.   | List of Parameters P105 to P108 .....                      | 131 |
| 17.     | REFERENCE VARIATION PERCENT MENU .....                     | 132 |
| 17.1.   | Overview .....   | 132 |
| 17.2.   | List of Parameters P115 to P121 .....                      | 133 |
| 18.     | SPEED LOOP AND CURRENT BALANCING MENU .....                | 134 |
| 18.1.   | Overview .....   | 134 |
| 18.2.   | List of Parameters P125 to P153 .....                      | 135 |
| 19.     | FOC REGULATORS MENU .....                                  | 138 |
| 19.1.   | Overview .....   | 138 |
| 19.2.   | List of Parameters P155 to P173 .....                      | 138 |
| 20.     | VTC REGULATORS MENU .....                                  | 141 |
| 20.1.   | Overview .....   | 141 |
| 20.2.   | List of Parameters P175h1 to P175w .....                   | 141 |
| 21.     | ANALOG AND FREQUENCY OUTPUTS MENU .....                    | 145 |
| 21.1.   | Overview .....   | 145 |
| 21.1.1. | Factory-setting of the Analog Outputs .....                | 145 |
| 21.1.2. | Analog Outputs .....                                       | 145 |
| 21.1.3. | Frequency Output .....                                     | 147 |
| 21.2.   | Variables .....  | 148 |
| 21.2.1. | Operating Mode of Analog and Frequency Outputs .....       | 149 |
| 21.2.2. | Analog Output Programming Examples .....                   | 150 |
| 21.3.   | List of Parameters P176 to P215 .....                      | 153 |
| 22.     | TIMERS MENU .....  | 162 |
| 22.1.   | Overview .....   | 162 |
| 22.2.   | List of Parameters P216 to P229 .....                      | 164 |
| 23.     | VTC DEAD TIME COMPENSATION MENU .....                      | 168 |
| 23.1.   | Overview .....   | 168 |
| 23.2.   | List of Parameters P230 to P234 .....                      | 168 |
| 24.     | PID PARAMETERS MENU .....                                  | 170 |
| 24.1.   | Overview .....   | 170 |

|         |   |     |
|---------|---|-----|
| 24.2.   | PID Regulator Tuning – Method of Ziegler and Nichols .....            | 171 |
| 24.3.   | Manual Tuning of the PI Regulator .....                               | 172 |
| 24.3.1. | Proportional Action (P) .....   | 172 |
| 24.3.2. | Integral Action (I) .....   | 174 |
| 24.3.3. | Derivative Action (D).....  | 176 |
| 24.3.4. | Tuning Actions at Constant Speed .....                                | 176 |
| 24.4.   | Anti-windup .....   | 176 |
| 24.5.   | List of Parameters P236 to P260 .....                                 | 177 |
| 25.     | PID2 PARAMETERS MENU .....  | 185 |
| 25.1.   | Overview .....  | 185 |
| 25.2.   | List of Parameters P436 to P460 .....                                 | 186 |
| 26.     | DIGITAL OUTPUTS MENU .....  | 187 |
| 26.1.   | Overview .....  | 187 |
| 26.1.1. | Factory Settings .....  | 187 |
| 26.1.2. | Structure of the Digital Outputs .....                                | 187 |
| 26.2.   | Programmable Operating Modes (Diagrams) .....                         | 195 |
| 26.3.   | Examples .....  | 198 |
| 26.4.   | List of Parameters P270 to P305 .....                                 | 203 |
| 27.     | AUXILIARY DIGITAL OUTPUTS MENU .....                                  | 217 |
| 27.1.   | Overview .....  | 217 |
| 27.2.   | List of Parameters P306 to P317 .....                                 | 217 |
| 28.     | MEASURE CONTROL FROM PT100 .....                                      | 221 |
| 28.1.   | Overview .....  | 221 |
| 28.2.   | List of Parameters P318 to P325 .....                                 | 221 |
| 29.     | FIELD BUS PARAMETERS MENU .....                                       | 224 |
| 29.1.   | Overview .....  | 224 |
| 29.2.   | List of Parameters P330 to P331 .....                                 | 224 |
| 30.     | VIRTUAL DIGITAL OUTPUTS (MPL) MENU .....                              | 226 |
| 30.1.   | Overview .....  | 226 |
| 30.1.1. | Factory Setting .....   | 226 |
| 30.1.2. | Structure of the Virtual Digital Outputs .....                        | 226 |
| 30.2.   | Operating Diagram of the Virtual Digital Outputs .....                | 232 |
| 30.3.   | List of Parameters P350 to P385 .....                                 | 236 |
| 31.     | INPUTS FOR REFERENCES FROM OPTIONAL BOARD .....                       | 250 |
| 31.1.   | Scaling Analog Inputs XAIN4, XAIN5.....                               | 250 |
| 31.2.   | List of parameters P390 to P399 .....                                 | 251 |
| 32.     | AUTOTUNE MENU .....   | 255 |
| 32.1.   | Overview .....  | 255 |
| 32.1.1. | Motor Autotune and Adjusting Loops .....                              | 255 |
| 32.1.2. | Checking the Encoder Operation .....                                  | 257 |
| 32.2.   | List of Inputs I073 - I074 .....                                      | 258 |
| 33.     | CARRIER FREQUENCY MENU .....  | 259 |
| 33.1.   | Overview .....  | 259 |
| 33.1.1. | IFD Control and VTC Control .....                                     | 259 |
| 33.1.2. | Example (IFD and VTC) .....   | 259 |
| 33.1.3. | FOC Control .....   | 260 |
| 33.1.4. | Any Control Algorithm.....  | 260 |
| 33.2.   | List of Parameters C001 to C004.....                                  | 261 |
| 34.     | MOTOR CONFIGURATION MENU .....  | 263 |
| 34.1.   | Overview .....  | 263 |
| 34.1.1. | Electrical Specifications of the Connected Motor .....                | 264 |
| 34.1.2. | Motor Ratings .....   | 264 |
| 34.1.3. | Parameters of the Equivalent Circuit of the Asynchronous Machine..... | 265 |
| 34.1.4. | V/f Pattern (IFD Only) .....  | 266 |
| 34.1.5. | Example 1 - V/f Pattern Parameterization .....                        | 267 |
| 34.1.6. | Example 2 - V/f Pattern Parameterization .....                        | 268 |
| 34.1.7. | Slip Compensation (IFD Only).....                                     | 268 |
| 34.1.8. | Torque Control (VTC and FOC Only) .....                               | 269 |
| 34.2.   | List of Parameters C008 to C128.....                                  | 270 |
| 34.3.   | Tables Including the Parameters Depending on the Drive Size.....      | 284 |
| 34.3.1. | Voltage Class 2T/4T .....   | 284 |
| 34.3.2. | Voltage Class 5T/6T .....   | 292 |
| 35.     | LIMITS MENU .....   | 296 |
| 35.1.   | Overview .....  | 296 |
| 35.2.   | List of Parameters C043 to C135.....                                  | 297 |
| 36.     | CONTROL METHOD MENU .....   | 300 |

- 36.1. Overview ..... 300
  - 36.1.1. Command Sources ..... 301
  - 36.1.2. Speed/Torque REFERENCE Sources ..... 303
  - 36.1.3. Alternative Command and Reference Sources ..... 305
  - 36.1.4. Torque Limit Source ..... 306
  - 36.1.5. Remote/Local Mode ..... 306
- 36.2. How to Manage the Reference Sources ..... 307
- 36.3. List of Parameters C140 to C148 ..... 309
- 37. DIGITAL INPUTS MENU ..... 312
  - 37.1. Overview ..... 312
    - 37.1.1. START ..... 314
    - 37.1.2. ENABLE (Terminals 15:MDI2 and S) ..... 315
    - 37.1.3. RESET (Terminal 16:MDI3) ..... 317
  - 37.2. Factory-setting of the Digital Inputs ..... 318
  - 37.3. List of Parameters C149 to C188c and I006 ..... 319
- 38. ENCODER/FREQUENCY INPUTS MENU ..... 339
  - 38.1. Overview ..... 339
    - 38.1.1. When ES836 is NOT Used ..... 339
    - 38.1.2. When Using ES836 or ES913 Optional Board ..... 340
    - 38.1.3. When Using Two Encoders ..... 341
  - 38.2. List of Parameters C189 to C199 ..... 343
- 39. BRAKING AND RAMP EXTENSION MENU ..... 347
  - 39.1. Overview ..... 347
    - 39.1.1. Braking module and ramp extension ..... 347
    - 39.1.2. Torque Limit and Frequency Increase Due to Overvoltage ..... 348
  - 39.2. List of Parameters C210 to C213d ..... 349
- 40. DC BRAKING MENU ..... 352
  - 40.1. Overview ..... 352
    - 40.1.1. DC Braking at Start and Non-condensing Function ..... 352
    - 40.1.2. DC Braking at Stop ..... 354
    - 40.1.3. DC Braking Command Sent from Terminal Board ..... 355
  - 40.2. List of Parameters C215 to C224 ..... 358
- 41. POWER DOWN MENU ..... 361
  - 41.1. Overview ..... 361
  - 41.2. List of Parameters C225 to C235 ..... 363
- 42. SPEED SEARCHING MENU ..... 367
  - 42.1. Overview ..... 367
  - 42.2. List of Parameters C245 to C250 ..... 370
- 43. AUTORESET MENU ..... 373
  - 43.1. Overview ..... 373
  - 43.2. List of Parameters C255 to C258 ..... 373
- 44. MOTOR THERMAL PROTECTION MENU ..... 375
  - 44.1. Overview ..... 375
  - 44.2. Choosing the Characteristic Parameters ..... 376
    - 44.2.1. IEC Class ..... 376
    - 44.2.2. Maximum Locked Rotor Time – Basic ..... 376
    - 44.2.3. Maximum Locked Rotor Time – Enhanced ..... 378
  - 44.3. Thermal Protection Trip Delay ..... 379
  - 44.4. List of Parameters C264 to C274 ..... 380
- 45. MAINTENANCE MENU ..... 382
  - 45.1. Overview ..... 382
  - 45.2. List of Parameters C275 to C278 ..... 382
- 46. PID CONFIGURATION MENU ..... 383
  - 46.1. Overview ..... 383
  - 46.2. Operation and Structure of the PID Regulator ..... 383
  - 46.3. List of Parameters C285 to C294 ..... 386
  - 46.4. Keeping Fluid Level Constant (Example) ..... 393
  - 46.5. Example of Compensation of Voltage Drop in a Filter ..... 396
    - 46.5.1. Voltage Drop Compensation – Feedback from Single Analog Input ..... 396
    - 46.5.2. Voltage Drop Compensation - Feedback from Two Analog Inputs ..... 397
- 47. BRIDGE CRANE MENU ..... 398
  - 47.1. Overview ..... 398
  - 47.2. List of Parameters C300 to C303 ..... 398
- 48. DATE AND TIME MENU ..... 401
  - 48.1. Overview ..... 401
  - 48.2. List of Parameters C310 to C316 ..... 404

|         |  |     |
|---------|--|-----|
| 49.     | TIMED FLAGS MENU .....                     | 407 |
| 49.1.   | Overview .....                             | 407 |
| 49.2.   | Examples .....                             | 407 |
| 49.3.   | List of Parameters from C330 to C357 ..... | 408 |
| 50.     | SERIAL COMMUNICATIONS .....                | 411 |
| 50.1.   | Overview .....                             | 411 |
| 50.2.   | MODBUS-RTU PROTOCOL .....                  | 411 |
| 51.     | SERIAL LINKS MENU .....                    | 414 |
| 51.1.   | Overview .....                             | 414 |
| 51.1.1. | Watchdog Alarms .....                      | 414 |
| 51.2.   | List of Parameters R001 to R013 .....      | 415 |
| 52.     | FIELDBUS CONFIGURATION MENU .....          | 418 |
| 52.1.   | Overview .....                             | 418 |
| 52.1.1. | Alarm A070 (Communication Suspended) ..... | 418 |
| 52.2.   | List of Parameters R016 to R017 .....      | 418 |
| 52.3.   | Exchanged Parameters .....                 | 420 |
| 52.3.1. | From the Master to the Sinus Penta .....   | 420 |
| 52.3.2. | From the Sinus Penta to the Master .....   | 424 |
| 53.     | EXPANSION BOARD CONFIGURATION MENU .....   | 426 |
| 53.1.   | Overview .....                             | 426 |
| 53.2.   | List of Parameters R021 to R023 .....      | 426 |
| 54.     | PROFIDRIVE BOARD CONFIGURATION MENU .....  | 427 |
| 54.1.   | Overview .....                             | 427 |
| 54.2.   | List of Parameters R025 to R045 .....      | 427 |
| 55.     | DAYLIGHT SAVING TIME .....                 | 430 |
| 55.1.   | Overview .....                             | 430 |
| 55.2.   | List of Parameters R050 to R053 .....      | 430 |
| 56.     | DATA LOGGER MENU .....                     | 432 |
| 56.1.   | Overview .....                             | 432 |
| 56.2.   | List of Parameters R115 and R116 .....     | 432 |
| 57.     | EEPROM MENU .....                          | 434 |
| 57.1.   | Overview .....                             | 434 |
| 57.2.   | List of Inputs I009 to I012 .....          | 435 |
| 58.     | ALARMS AND WARNINGS .....                  | 436 |
| 58.1.   | What Happens When a Protection Trips ..... | 436 |
| 58.2.   | What To Do When an Alarm Trips .....       | 437 |
| 58.3.   | Alarm List .....                           | 438 |
| 58.4.   | List of the DRIVECOM Alarm Codes .....     | 456 |
| 58.5.   | Warnings .....                             | 458 |
| 58.6.   | Warning List .....                         | 459 |
| 58.7.   | State List .....                           | 460 |
| 59.     | CUSTOM PARAMETERS .....                    | 461 |
| 60.     | INDEX .....                                | 471 |

## 0.2. Figures

---

|  |     |
|--|-----|
| Figure 1: Menu Tree.....   | 20  |
| Figure 2: Navigation example .....   | 21  |
| Figure 3: Display/keypad .....   | 27  |
| Figure 4: Example of S ramps.....  | 94  |
| Figure 5: Speed profile without Rounding Off and with Rounding Off 2 (example).....          | 95  |
| Figure 6: Speed profile with Acceleration Reset - Yes to No (Example).....                   | 96  |
| Figure 7: Speed Reference computing .....  | 106 |
| Figure 8: Torque Reference computing .....   | 107 |
| Figure 9: Computing Speed Analog Reference from terminal board: AIN1 .....                   | 109 |
| Figure 10: Computing Inputs REF (1) and (2) (examples).....                                  | 110 |
| Figure 11: Computing REF Input (Example 3).....  | 111 |
| Figure 12: Prohibit Speed ranges .....   | 130 |
| Figure 13: Speed Control (example).....  | 132 |
| Figure 14: Dual Parameterization function (example).....                                     | 134 |
| Figure 15: Typical structure of the Analog Outputs.....                                      | 146 |
| Figure 16: Structure of the Frequency Output.....  | 147 |
| Figure 17: Curve (voltage; speed) implemented by AO1 (Example 1).....                        | 150 |
| Figure 18: Curve (voltage; speed) implemented by AO1 (Example 2).....                        | 151 |
| Figure 19: Curve (voltage; speed) implemented by AO1 (Example 3).....                        | 151 |
| Figure 20: Curve (voltage; speed) implemented by AO1 (Example 4).....                        | 152 |
| Figure 21: Curve (voltage; speed) implemented by AO1 (Example 5).....                        | 152 |
| Figure 22: Using Timers (example).....   | 163 |
| Figure 23: PID Block Diagram .....   | 170 |
| Figure 24: Permanent oscillation with $K_p$ , critical gain .....                            | 171 |
| Figure 25: Response to a system tuned with the method of Ziegler and Nichols .....           | 172 |
| Figure 26: Response to the step based on the value of $K_p$ when $T_i$ is kept constant..... | 173 |
| Figure 27: Response to the step when $K_p$ is too large .....                                | 174 |
| Figure 28: Response to the step based on the value of $T_i$ when $K_p$ is kept constant..... | 175 |
| Figure 29: Response to the step when the values of $K_p$ and $T_i$ are too small.....        | 175 |
| Figure 30: PID Sleep and Wake-up Mode when P237a is set to 1 .....                           | 179 |
| Figure 31: MDO block-diagram .....   | 187 |
| Figure 32: DIGITAL Mode .....  | 195 |
| Figure 33: ANALOG Mode .....   | 196 |
| Figure 34: DOUBLE DIGITAL Mode .....   | 196 |
| Figure 35: General structure of the parameterization of a digital output.....                | 197 |
| Figure 36: Digital output for speed thresholds (example) .....                               | 199 |
| Figure 37: Electromechanical brake command (example).....                                    | 200 |
| Figure 38: Block diagram of the virtual digital outputs (MPL).....                           | 226 |
| Figure 39: Example of MPL functionality.....   | 232 |
| Figure 40: Carrier frequency (example) .....   | 259 |
| Figure 41: Equivalent circuit of the asynchronous machine.....                               | 265 |
| Figure 42: Types of programmable V/f curves .....  | 266 |
| Figure 43: Torque control with speed limit .....   | 274 |
| Figure 44: Current limit decreased based on the carrier frequency.....                       | 296 |
| Figure 45: Selecting the command sources.....  | 301 |
| Figure 46: Selecting the source references .....   | 305 |
| Figure 47: Inputs that can be selected to implement control functions.....                   | 312 |
| Figure 48: The ENABLE Function.....  | 315 |
| Figure 49: Controlling Run and Direction when the STOP Input is not programmed.....          | 323 |
| Figure 50: Controlling Run and Direction when the STOP Input is programmed.....              | 324 |
| Figure 51: Using two encoders (example) .....  | 341 |
| Figure 52: DCB Hold and DCB at Start.....  | 352 |
| Figure 53: DCB at Start with VTC Control.....  | 353 |
| Figure 54: DCB at Stop.....  | 354 |
| Figure 55: Manual DCB (Example 1) .....  | 355 |
| Figure 56: Manual DCB (Example 2) .....  | 356 |
| Figure 57: Manual DCB (Example 3) .....  | 357 |
| Figure 58: Power Down (Example) .....  | 361 |
| Figure 59: Speed Searching (Example 1).....  | 368 |
| Figure 60: Speed Searching (Example 2).....  | 369 |
| Figure 61: Trip current drop depending on speed values .....                                 | 375 |
| Figure 62: Set up of parameter C267 depending on the LRC/FLC ratio.....                      | 378 |
| Figure 63: Trip delay of alarm A075 based on the IEC Class .....                             | 379 |
| Figure 64: Structure of the PID Regulator.....   | 383 |

|  |     |
|--|-----|
| Figure 65: Reference source and feedback source selection..... | 384 |
| Figure 66: PID ramp reference .....                            | 385 |
| Figure 67: Details of the PID regulator structure.....         | 385 |
| Figure 68: Keeping fluid level constant (Example).....         | 393 |

### 0.3. Tables

|   |     |
|---|-----|
| Table 1: Coding of Measures M031, M032.....   | 60  |
| Table 2: Coding of Measures M033.....   | 60  |
| Table 3: Coding of Measures M034, M035.....   | 61  |
| Table 4: Coding of Measures M036, M036a, M036b.....   | 61  |
| Table 5: Coding of Measure M056.....  | 66  |
| Table 6: Coding of Measure M056a.....   | 66  |
| Table 7: Coding of Measure M056b.....   | 66  |
| Table 8: Coding of Measure M061.....  | 67  |
| Table 9: Data Logger connection status.....   | 72  |
| Table 10: Coding of the functions assigned to the digital inputs.....                                 | 74  |
| Table 11: Modbus base addresses in the Fault Lists.....   | 76  |
| Table 12: List of the measures in the Fault Lists.....  | 76  |
| Table 13: List of the measures in the Power Off List.....   | 78  |
| Table 14: List of parameter P263 and Fire Mode Enable Password.....                                   | 79  |
| Table 15: Indexes corresponding to the different models (sizes) of the Penta Drive.....               | 80  |
| Table 16: Voltage classes of the PD.....  | 80  |
| Table 17: Fan control modes.....  | 81  |
| Table 18: Coding for fan activation.....  | 81  |
| Table 19: List of parameters P000 to P003.....  | 83  |
| Table 20: List of parameters P264 to P269b.....   | 87  |
| Table 21: Preset PID units of measure.....  | 90  |
| Table 22: Example of a Speed Ramp.....  | 93  |
| Table 23: List of parameters P009 to P033.....  | 97  |
| Table 24: Parameters used for the Inputs for References Menu.....                                     | 105 |
| Table 25: Analog Input Hardware Mode.....   | 108 |
| Table 26: List of parameters P050 to P074a.....   | 112 |
| Table 27: List of parameters P080 to P100.....  | 124 |
| Table 28: List of parameters P080a ÷ P099a.....   | 128 |
| Table 29: List of parameters P105 to P108.....  | 131 |
| Table 30: List of parameters P115 to P121.....  | 133 |
| Table 31: List of parameters P125 to P153.....  | 135 |
| Table 32: List of parameters P155 to P173.....  | 138 |
| Table 33: List of Parameters P175a1 to P175w.....   | 141 |
| Table 34: Variables to be selected for the Analog and Frequency Outputs.....                          | 148 |
| Table 35: Programming AO1 (0÷ 10V).....   | 150 |
| Table 36: Programming AO1 (0 ÷ 10V).....  | 150 |
| Table 37: Programming AO1 (ABS 0 ÷ 10V).....  | 151 |
| Table 38: Programming AO1 (ABS 0 ÷ 10V).....  | 152 |
| Table 39: Programming AO1 (± 10V).....  | 152 |
| Table 40: List of parameters P176 to P215.....  | 153 |
| Table 41: List of parameters P216 to P229.....  | 164 |
| Table 42: Coding of P226: Timers assigned to digital inputs MDI 1÷4.....                              | 166 |
| Table 43: List of parameters P230 to P234.....  | 168 |
| Table 44: List of parameters P236 to P260.....  | 177 |
| Table 45: List of parameters P436 to P460.....  | 186 |
| Table 46: Digital Output Mode.....  | 188 |
| Table 47: List of the selectable digital inputs and analog outputs.....                               | 189 |
| Table 48: Test functions.....   | 192 |
| Table 49: MDO parameterization for PD Status OK.....  | 198 |
| Table 50: MDO parameterization for drive Run OK.....  | 198 |
| Table 51: MDO parameterization for speed thresholds.....  | 199 |
| Table 52: MDO parameterization for electromechanical brake command.....                               | 200 |
| Table 53: MDO parameterization for the PWM function.....  | 201 |
| Table 54: MDO parameterization for the Ready state of a PLC supervisor.....                           | 202 |
| Table 55: List of parameters P270 to P305.....  | 203 |
| Table 56: List of parameters P306 to P317.....  | 217 |
| Table 57: List of parameters P318 to P325.....  | 221 |
| Table 58: List of parameters P330 to P331.....  | 224 |
| Table 59: List of the programmable measures in P330 to P331 and P268, P268a, P268b, P268c, P268d..... | 225 |

|  |     |
|--|-----|
| Table 60: Digital Output Modes.....  | 227 |
| Table 61: Test functions.....  | 228 |
| Table 62: MPL parameterization for Dry Run Detection.....                          | 233 |
| Table 63: MPL parameterization for Pipe Fill function .....                        | 235 |
| Table 64: List of parameters P350 to P385 .....                                    | 236 |
| Table 65: Analog input hardware mode .....   | 250 |
| Table 66: List of parameters P390 to P399 .....                                    | 251 |
| Table 67: Programmable “Motor Tune” functions .....                                | 256 |
| Table 68: List of inputs I073 - I074.....  | 258 |
| Table 69: Maximum value of the output frequency depending on the Penta size.....   | 260 |
| Table 70: List of parameters C001 to C004.....                                     | 261 |
| Table 71: Description of the parameters classified by motor .....                  | 264 |
| Table 72: Motor ratings .....  | 264 |
| Table 73: Parameters of the equivalent circuit of the asynchronous machine.....    | 265 |
| Table 74: Motor parameters used by control algorithms.....                         | 265 |
| Table 75: IFD control parameters for the connected motors .....                    | 267 |
| Table 76: Parameters setting Slip Compensation (IFD Control).....                  | 268 |
| Table 77: List of parameters C008 to C128.....                                     | 270 |
| Table 78: Equivalence between AC mains range and DC range.....                     | 272 |
| Table 79: Parameters depending on the Drive Size and Model / Class 2T/4T / 1 ..... | 284 |
| Table 80: Parameters depending on the Drive Size and Model - Class 2T/4T / 2 ..... | 286 |
| Table 81: Parameters depending on the Drive Size and Model - Class 2T/4T / 3 ..... | 288 |
| Table 82: Parameters depending on the Drive Size and Model - Class 2T/4T / 4 ..... | 290 |
| Table 83: Parameters depending on the Drive Size and Model - Class 5T/6T / 1 ..... | 292 |
| Table 84: Parameters depending on the Drive Size and Model - Class 5T/6T / 2 ..... | 293 |
| Table 85: Parameters depending on the Drive Size and Model - Class 5T/6T / 3 ..... | 294 |
| Table 86: Parameters depending on the Drive Size and Model - Class 5T/6T / 4 ..... | 295 |
| Table 87: List of parameters C043 to C135.....                                     | 297 |
| Table 88: Remote command inputs from serial link.....                              | 302 |
| Table 89: Reference inputs from serial link.....                                   | 304 |
| Table 90: List of parameters C140 to C148.....                                     | 309 |
| Table 91: Unprogrammable functions.....  | 313 |
| Table 92: Terminals used for other inputs .....                                    | 313 |
| Table 93: Terminal board: Factory-setting .....                                    | 318 |
| Table 94: List of parameters C149 to C188c and I006 .....                          | 319 |
| Table 95: Multispeed selection .....   | 326 |
| Table 96: Selected Speed reference .....   | 326 |
| Table 97: Multiramp selection .....  | 329 |
| Table 98: Selected ramp.....   | 329 |
| Table 99: Motor selection.....   | 332 |
| Table 100: Selection of the speed reference variation.....                         | 333 |
| Table 101: Variation of the selected speed reference .....                         | 333 |
| Table 102: Selection of PID Multireferences.....                                   | 338 |
| Table 103: List of parameters C189 to C199 .....                                   | 343 |
| Table 104: Coding of C189 .....  | 344 |
| Table 105: Coding of C199 .....  | 346 |
| Table 106: List of parameters C210 to C213d.....                                   | 349 |
| Table 107: List of parameters C215 to C224 .....                                   | 358 |
| Table 108: List of parameters C225 to C235 .....                                   | 363 |
| Table 109: List of parameters C245 to C250 .....                                   | 370 |
| Table 110: List of parameters C255 to C258 .....                                   | 373 |
| Table 111: Suggested values for the motor thermal time constant.....               | 376 |
| Table 112: Typical datasheet for 4-pole, 50Hz-400V motors.....                     | 377 |
| Table 113: List of parameters C264 to C274 .....                                   | 380 |
| Table 114: List of parameters C275 to C278 .....                                   | 382 |
| Table 115: Reference sources from serial link.....                                 | 386 |
| Table 116: List of parameters C285 to C294 .....                                   | 386 |
| Table 117: List of parameters C300 to C303 .....                                   | 398 |
| Table 118: List of Parameters C310 to C316.....                                    | 404 |
| Table 119: List of Parameters C330 ÷ C357.....                                     | 408 |
| Table 120: List of parameters R001 to R013.....                                    | 415 |
| Table 121: List of parameters R016 to R017 .....                                   | 418 |
| Table 122: List of parameters R021 to R023 .....                                   | 426 |
| Table 123: List of parameters R025 to R045.....                                    | 427 |
| Table 124: List of Parameters R050 to R053.....                                    | 430 |
| Table 125: List of parameters R115 and R116 .....                                  | 432 |
| Table 126: Preset connections .....  | 433 |
| Table 127: List of programmable inputs I009 to I012.....                           | 435 |



|  |     |
|--|-----|
| Table 128: List of the possible alarms .....     | 438 |
| Table 129: List of the DRIVECOM alarm codes..... | 456 |
| Table 130: Warning list.....                     | 459 |
| Table 131: State list .....                      | 460 |

## 0.4. Scope of this Manual

---

Elettronica Santerno is committed to update its User Manuals available for download from [santerno.com](http://santerno.com) with the latest software version officially released. Please contact Elettronica Santerno if you require technical documents related to previous software versions.

## 0.5. How to Use this Manual

---

### 0.5.1. OVERVIEW

This User Manual (Programming Guide) provides any information required to setup and monitor the drives of the Sinus Penta series manufactured by Elettronica Santerno SpA.

Setup/monitoring may be obtained using one of the following options:

- Display/keypad unit;
- Serial link through RS485 standard port or ES822 (isolated optional serial board) RS485/RS32;
- ES851 (optional Data Logger and communications board).

For the instructions on how to use and remote the display/keypad unit, please refer to the Sinus Penta's Installation Guide.

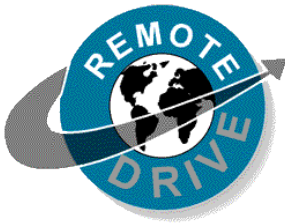

Any information sent to/from the drive via the display/keypad unit may be obtained also via serial link using the RemoteDrive software application offered by Elettronica Santerno. RemoteDrive allows the following functions: image acquisition, keypad simulation, oscilloscope functions and multifunction tester, data logger, table compiler including history data, parameter setup and data reception-transmission-storage from and to a calculator, scan function for the automatic detection of the connected drives (up to 247 drives may be connected).

You can also create your own dedicated software via serial communication link. This manual provides any information concerning addressing (Address field) and scaling (Range field) for the drive interfacing.

### 0.5.2. SPECIAL APPLICATIONS DEDICATED TO SINUS PENTA DRIVES

Special software is supplied with the drives of the Sinus Penta series, that can be used for particular applications. The menu tree, the programming mode and navigation mode of the Sinus Penta are used; parameters or menus will be added/(removed) whether required/(not required) for the implemented application.

The dedicated applications implement the most common automation applications, thus replacing PLCs or dedicated control boards, and they reduce to a minimum the electric equipment required, thus ensuring lower maintenance costs.

Such operating modes can be implemented through the firmware updating and/or through additional interface boards.

The following applications are currently available:

| Identifier | Application                                    |
|------------|--|
| PD         | Sinus Penta Drive (Asynchronous Motor control) |
| PR         | Sinus Penta – Regenerative                     |
| PS         | Sinus Penta – Synchronous Motor Control        |



**NOTE**

In order to install your application SW and update the firmware packages of the SINUS PENTA drive, you can use the Remote Drive software provided by Elettronica Santerno. Please refer to the Remote Drive DRIVE REMOTE CONTROL – User Manual for detailed instructions.

Any detail concerning optional functionality is given in separate manuals covering SINUS PENTA's optional applications.

### 0.5.3. MENUS AND SUBMENUS

This User Manual (Programming Guide) is divided into different Menus. Their sequence is the same as their display sequence in the display/keypad and the RemoteDrive software.

Programming parameters and Measure parameters are divided into:

**Mxxx** Measures (always Read Only):

|             |                 |   |  |
|-------------|-----------------|---|--|
| <b>Mxxx</b> | <b>Range</b>    | Drive representation (integer)                              | Display on the display/keypad and the RemoteDrive (may be a decimal figure) plus unit of measure |
|             | <b>Active</b>   | Type of control (IFD / VTC / FOC) the measure is related to |  |
|             | <b>Address</b>  | Modbus address which the measure can be read from (integer) |  |
|             | <b>Function</b> | Measure description   |  |

**Pxxx** Parameters (always R/W):

|             |                 |   |  |
|-------------|-----------------|---|--|
| <b>Pxxx</b> | <b>Range</b>    | Drive representation (integer)  | Display on the display/keypad and the RemoteDrive (may be a decimal figure) plus unit of measure |
|             | <b>Default</b>  | Factory-setting of the parameter (as represented for the drive)   | Factory-setting of the parameter (as displayed) plus unit of measure                             |
|             | <b>Level</b>    | User level (BASIC / ADVANCED / ENGINEERING)   |  |
|             | <b>Address</b>  | Modbus address which the parameter can be read from (integer)   |  |
|             | <b>Control</b>  | This optional field is displayed when a parameter is not active for all types of motor controls (IFD / VTC / FOC) |  |
|             | <b>Function</b> | Parameter description   |  |

**Cxxx** Parameters (Read Only when the drive is running and the motor is operating; R/W when the drive is in stand-by or in Run, but the motor is stopped: see **P003** in PASSWORD AND USER LEVEL MENU).

|             |                 |   |  |
|-------------|-----------------|---|--|
| <b>Cxxx</b> | <b>Range</b>    | Drive representation (integer)  | Display on the display/keypad and the RemoteDrive (may be a decimal figure) plus unit of measure |
|             | <b>Default</b>  | Factory-setting of the parameter (as represented for the drive)   | Factory-setting of the parameter (as displayed) plus unit of measure                             |
|             | <b>Level</b>    | User level (BASIC / ADVANCED / ENGINEERING)   |  |
|             | <b>Address</b>  | Modbus address which the parameter can be read from/written to (integer)  |  |
|             | <b>Control</b>  | This optional field is displayed when a parameter is not active for all types of motor controls (IFD / VTC / FOC) |  |
|             | <b>Function</b> | Parameter description   |  |

**Rxxx** Parameters (Read Only when the drive is in Run; R/W when the drive is in stand-by or in Run, but the motor is stopped: see **P003** Condition required for changing C parameters in the PASSWORD AND USER LEVEL MENU).

|             |                 |   |  |
|-------------|-----------------|---|--|
| <b>Rxxx</b> | <b>Range</b>    | Drive representation (integer)  | Display on the display/keypad and the RemoteDrive (may be a decimal figure) plus unit of measure |
|             | <b>Default</b>  | Factory-setting of the parameter (as represented for the drive)   | Factory-setting of the parameter (as displayed) plus unit of measure                             |
|             | <b>Level</b>    | User level (BASIC / ADVANCED / ENGINEERING)   |  |
|             | <b>Address</b>  | Modbus address which the parameter can be read from/written to (integer)  |  |
|             | <b>Control</b>  | This optional field is displayed when a parameter is not active for all types of motor controls (IFD / VTC / FOC) |  |
|             | <b>Function</b> | Parameter description   |  |



**NOTE**

Unlike **Cxxx** parameters, **Rxxx** parameters become active only after the drive has been switched off and switched on again, or after resetting its control board by pressing the **RESET** button for more than 5 seconds.

**Ixxx** Inputs. These are not parameters, but inputs (the values allocated to these inputs are not stored to non-volatile memory. Ixxx value is always 0 when the drive is powered on).

|             |                 |   |  |
|-------------|-----------------|---|--|
| <b>Ixxx</b> | <b>Range</b>    | Drive representation (integer)  | Display on the display/keypad and the RemoteDrive (may be a decimal figure) plus unit of measure |
|             | <b>Level</b>    | User level (BASIC / ADVANCED / ENGINEERING)   |  |
|             | <b>Address</b>  | Modbus address which the input can be read from/written to (integer)  |  |
|             | <b>Control</b>  | This optional field is displayed when a parameter is not active for all types of motor controls (IFD / VTC / FOC) |  |
|             | <b>Function</b> | Input description   |  |



**NOTE**

Use the **ESC** key to enter the value of an **Ixxx** input. If the **SAVE/ENTER** key is used, **W17 SAVE IMPOSSIBLE** (warning) is displayed.



**NOTE**

When changing a **Pxxx** or **Cxxx** parameter via the display/keypad, you may activate its new value immediately (flashing cursor) or when you quit the programming mode (fixed cursor). Typically, numeric parameters immediately come to effect, while alphanumeric parameters have a delayed effect.



**NOTE**

When changing a **Pxxx** or **Cxxx** parameter via the RemoteDrive, the drive will immediately use the new parameter value.

### 0.5.4. ALARMS AND WARNINGS

The last part of this User Manual covers alarms (**Axxx**) and warnings (**Wxxx**) displayed by the drive:

|             |                       |  |
|-------------|-----------------------|--|
| <b>Axxx</b> | <b>Description</b>    |  |
|             | <b>Event</b>          |  |
|             | <b>Possible cause</b> |  |
|             | <b>Solution</b>       |  |

## 1. USING THE DISPLAY/KEYPAD UNIT

### 1.1. Overview

---

This section contains several examples about navigating in the display/keypad unit and the UPLOAD and DOWNLOAD functions of the programming settings of the drive when using the keypad.

More details about the keypad settings (contrast, backlight, etc.) are given in the section covering the display/keypad in the Installation Guide. Details about custom navigation in the root page, the measures in the Keypad page and the Root page and the custom unit of measure of the PID controller are given in the DISPLAY/KEYPAD MENU in this manual.

When using the navigation “by menu” mode (**P264** = BY MENU), the structure of the menu tree that can be explored using the display/keypad is described in the Menu Tree section.

The complete tree structure is displayed, but the actual structure depends on the user level set in **P001** and on the implemented programming. For example, if only motor 1 is programmed (**C009**=1), the menus relating to motors 2 and 3 will not be displayed (Motor 2/3 Configuration and Motor 2/3 Limit). Also, if the type of motor control is **C010**=IFD Voltage/Freq., the BRIDGE CRANE MENU will not be displayed.

When **P264** = Linear (linear navigation), the parameters displayed are no longer grouped into menus, and you can scroll through all parameters using the ▲ and ▼ keys.

When **P264** = Modified Pars. Only, only the parameters having different values than the factory settings are displayed, and you can scroll through all parameters using the ▲ and ▼ keys.

The Navigation section shows how to use function keys to navigate through the parameters and to change parameter values (**P264** = BY MENU).

The function keys and their functionality are described below.

## 1.2. Menu Tree

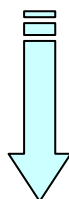
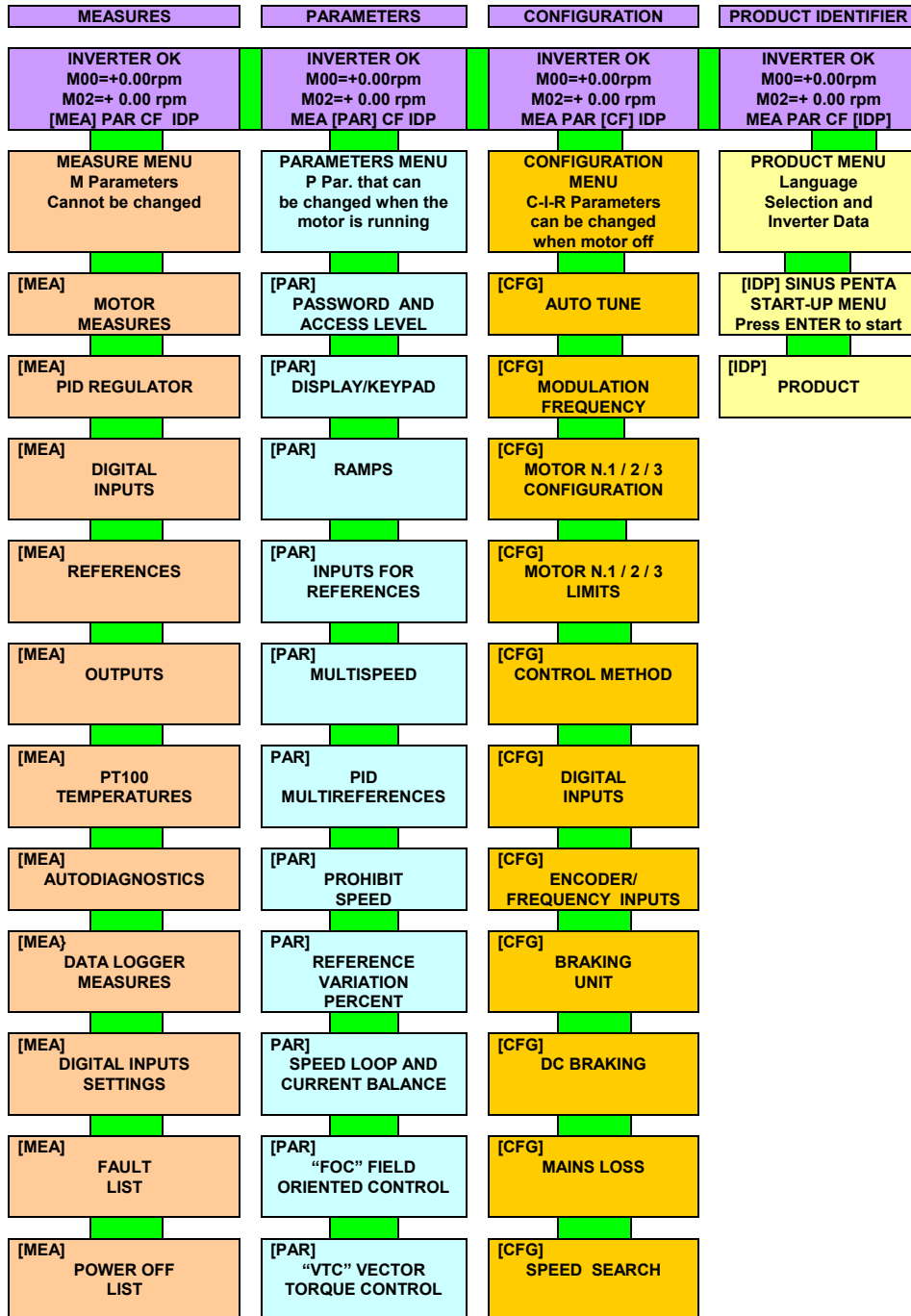

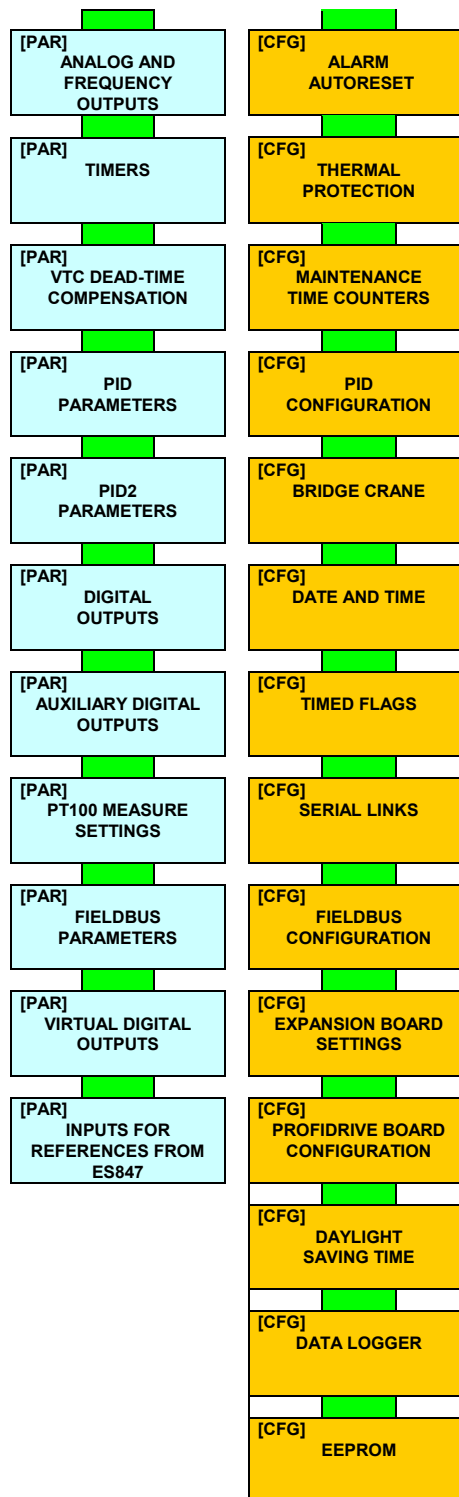
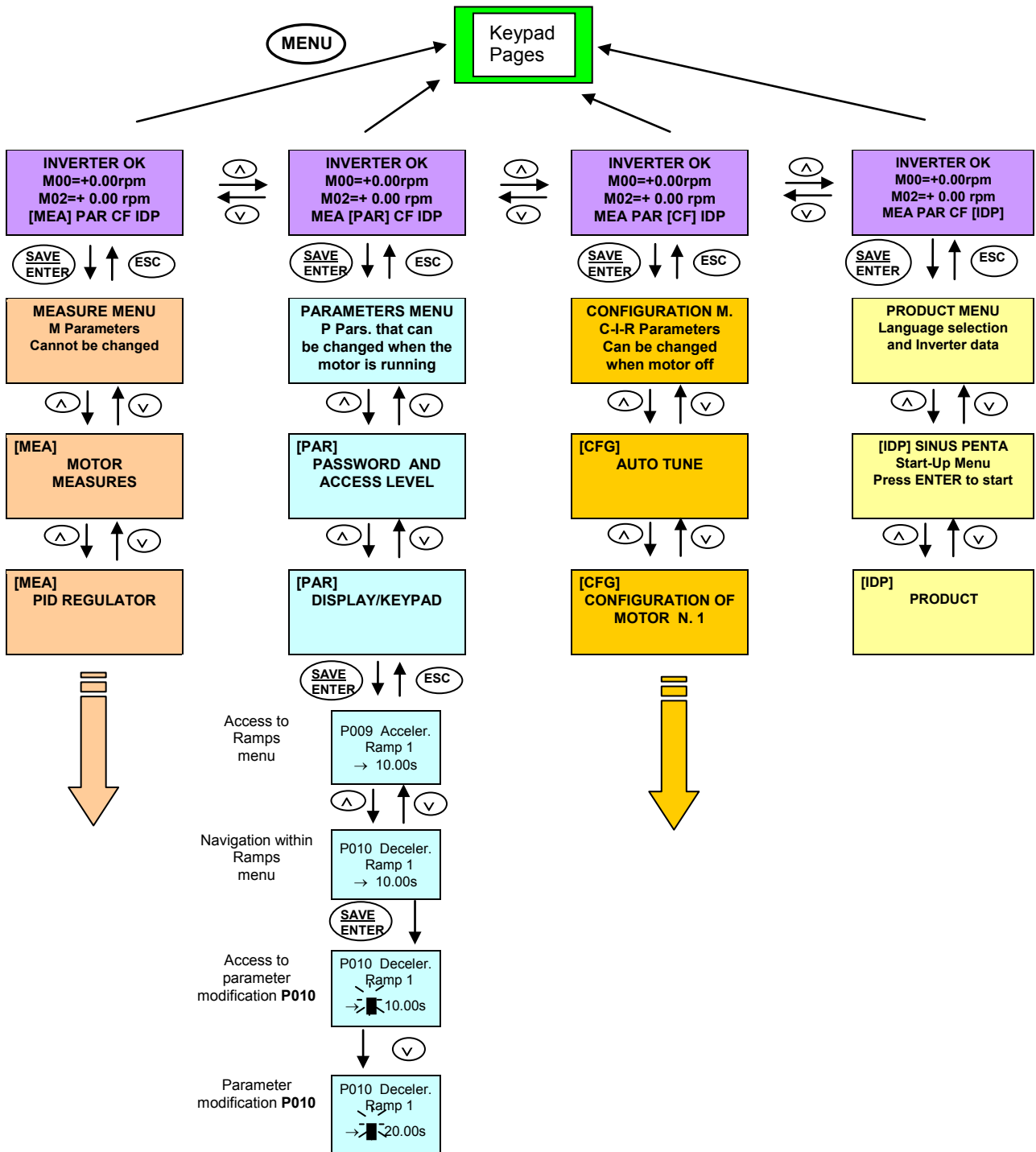

Figure 1: Menu Tree

### 1.3 Navigation

Figure 2: Navigation example



If the **ESC** key is pressed to quit, the new parameter value will be acknowledged but not saved to non-volatile memory, and will therefore be lost at power off. Press **SAVE/ENTER** to confirm parameter alteration.

## 1.4. Parameter Modification

---

Factory setting allows parameter modification. The parameters included in the Parameters Menu (**Pxxx** parameters) can be changed at any moment, whereas the parameters included in the Configuration Menu (**Cxxx**, **Rxxx**, **Ixxx** parameters) can be changed only when the motor is stopped.

For safer operating conditions, the configuration parameters must be changed only when the drive is disabled (the **ENABLE-A** and **ENABLE-B** commands are inactive): to do so, **P003** must be set to **0 (stand-by only)**.

To disable parameter changes, just change **P000** (write enable) and save its new setting. **P000** and **P002** (password) are both factory-set to 1. If **P000=0**, an inexperienced user cannot change parameter values, but if **P000=1**, an advanced user will be able to change the parameter values.

For even safer operating conditions, you can change the password stored in **P002**; in that case, you must set **P000** accordingly.



**NOTE** Note down and keep at hand the value set in **P002**.

Press the **SAVE/ENTER** key for parameter modifications; when a flashing cursor appears, press **▲** and **▼** to change the parameter value. Do one of the following to quit the editing mode:

Press **ESC** with **P269b = 0**: [No] → the parameter value used by the drive is changed and is maintained until the drive is shut down, then the value is lost when the drive is powered on again.

Press **ESC** with **P269b = 1**: [YES] → the previous value is restored.

Press **SAVE/ENTER** → the parameter value is used by the inverter and stored to non-volatile memory and is not deleted when the drive is shut down.

Inputs (**Ixxx**) cannot be saved to non-volatile memory and are automatically set to their default values.

**Rxxx** parameters become active only when the drive control board has been reset by pressing the **RESET** key for a few seconds or by switching off the drive.

## 1.5. Programming the Root Page

---

When the drive is turned on, the Root page is displayed as the starting page. The Root page allows you to access the main menus (Measures, Parameters, Configuration, Product ID) or to shift to the Keypad pages using the **MENU** key.

**Root page**

|   |   |   |   |   |   |   |   |   |       |       |   |   |
|---|---|---|---|---|---|---|---|---|-------|-------|---|---|
| I | N | V | E | R | T | E | R |   | O     | K     |   |   |
|   | + |   | 1 | 5 | 0 | 0 | . | 0 | 0     | r p m |   |   |
|   | + |   |   |   | 0 | . | 0 | 0 | r p m |       |   |   |
| M | E | A | [ | P | A | R | ] | C | F     | I     | D | P |

You can customise the root page using parameter **P265** (see the DISPLAY/KEYPAD MENU).

## 1.6. Using the MENU Key

The **MENU** key allows going to the next menu. From the Root page, press the MENU key to enable circular navigation.

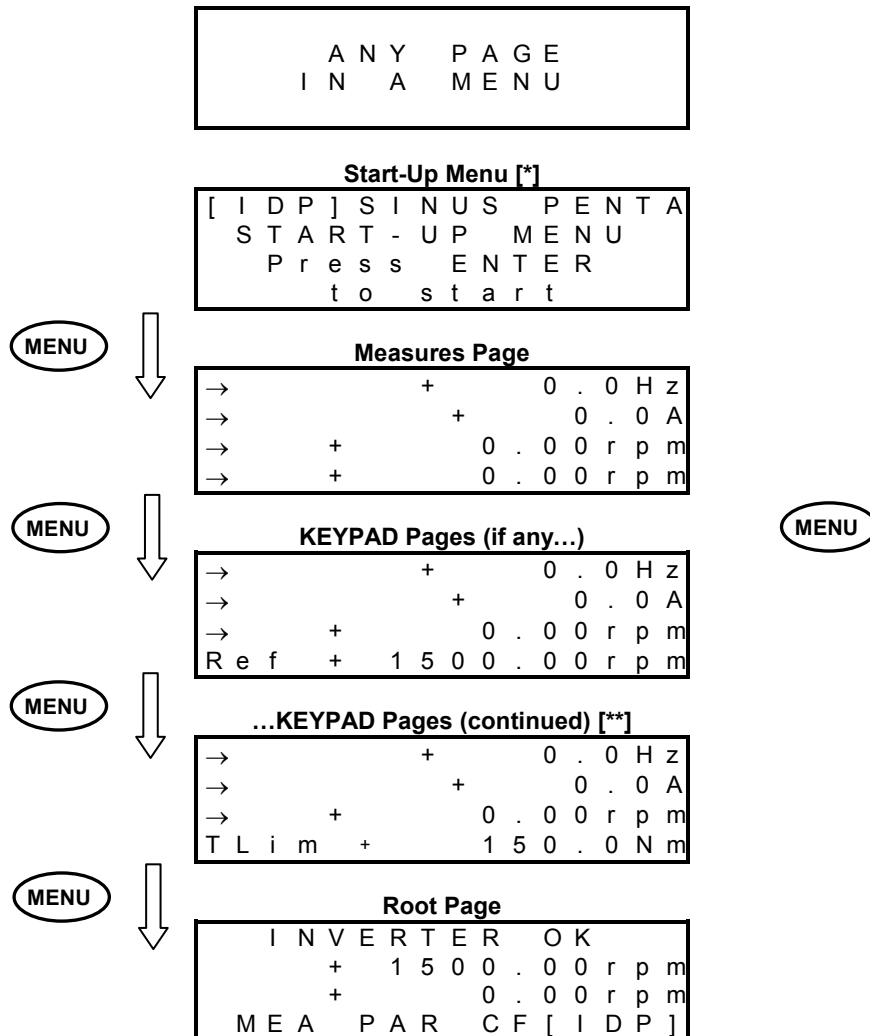

**NOTE [\*]** The Start-Up menu is available only if **P265=3: Start-Up** (see the DISPLAY/KEYPAD MENU).



**NOTE [\*\*]** The Keypad pages are available only if the relevant references / feedback / limits are activated (see the CONTROL METHOD MENU and the PID CONFIGURATION MENU).



3. Press the following keys to quit the last page displayed:
  - **ESC** without saving the value to EEPROM if **P269b = 0:[No]** → press **ESC** to confirm the parameter, that will not be saved (the previous value will be restored at next power on);
  - **ESC** without saving the value to EEPROM if **P269b = 1:[No]** → press **ESC** to restore the previous value;
  - **SAVE/ENTER** (new values are saved to Eeprom).

## 1.8. RESET Key (Alarm and Control Board Reset)

The **RESET** key is used to reset the drive after an alarm trips and the cause responsible for the alarm has been removed.

Press the **RESET** key for **more than 5 seconds to reset the control board and reinitiate it**. This procedure may be useful when changes made to **Rxxx** parameters (which activate only after resetting the equipment) must immediately come to effect, with no need to switch off the drive.

## 1.9. TX/RX Key (Download/Upload from/to the Keypad)

Use the keypad to perform the following functions:

1. **UPLOAD** (parameters stored in the drive are copied to the display/keypad);
2. **DOWNLOAD** (parameters stored in the keypad are copied to the drive).

Press the **TX/RX** key to go to the **UPLOAD** page; press the **TX/RX** key again to toggle between the **UPLOAD** and **DOWNLOAD** pages.



**CAUTION**

A Warning is displayed (one among **W41** to **W46**) when trying to **DOWNLOAD** parameters to a drive whose SW Version, IDP, PIN or current/voltage classes are different from those of the drive previously used for parameter **UPLOAD**. In that case, download is not allowed.



**NOTE**

The **DOWNLOAD** function allows the parameters stored in the keypad to be copied to the drive. However, parameters are not stored to the non-volatile memory of the drive. To store the downloaded parameters to the non-volatile memory of the drive, go to the **EEPROM** menu and execute a "Save Work" command once the download procedure is complete. Otherwise, when power is lost, the parameters downloaded to the drive are lost.

The **TX/RX** key is disabled under the following conditions:

- no password is entered in **P000**
- the **OPERATOR** mode is activated with the **MENU** Key (**P264b = OPERATOR**)
- the drive is running.

In the example below, you can go to the **UPLOAD** page from any page (the upper LED starts flashing). If you then press the **TX/RX** key, you can go to the **UPLOAD** and **DOWNLOAD** pages.

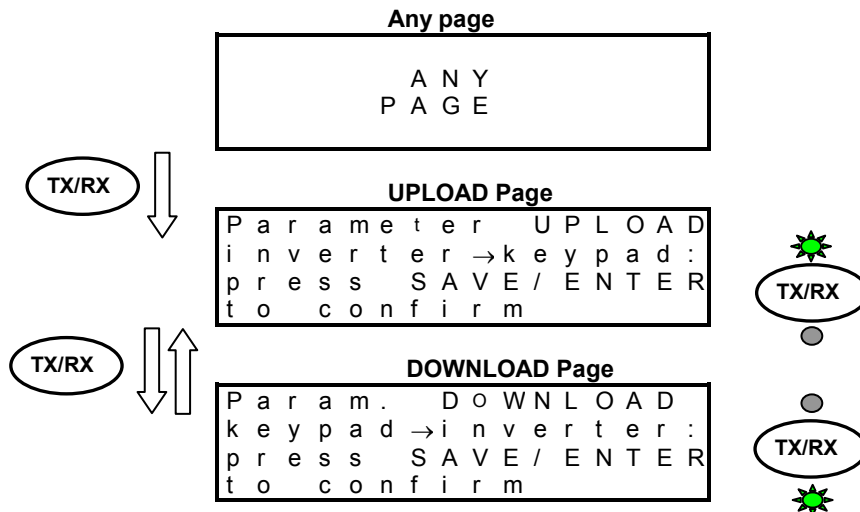

Press **SAVE/ENTER** from the **UPLOAD** (/ **DOWNLOAD**) page to confirm **UPLOADING** (/ **DOWNLOADING**). The relevant LED will come on (fixed light).

If the **SAVE/ENTER** key is not pressed for confirmation within 10 seconds from the selection of the UPLOAD (/DOWNLOAD) page, the starting page is automatically displayed.

While UPLOADING, **W08 UPLOADING** (flashing warning) appears.  
If parameters are successfully uploaded, the following warning appears:  
W11 UPLOAD OK  
If not, the **W12 UPLOAD KO** warning appears. [Retry parameter upload.](#)

While DOWNLOADING, **W07 DOWNLOADING** (flashing warning) appears.  
If parameters are successfully downloaded, the following warning appears:  
**W09 DOWNLOAD OK**  
If not, alarm **A073** trips, and download must be retried before restarting the drive.

## 1.10. LOC/REM Key (Keypad Pages)

---

To enable the Local/Remote operating mode (Remote sources are command and/or reference sources other than the display/keypad) press the **LOC/REM** key in the display/keypad, or use a digital input configured as **Loc/Rem** (see **C180**).



### NOTE

The **LOC/REM** key is enabled when no digital input is configured as **Loc/Rem**, or when a digital input is configured as a **Loc/Rem** button (see **C180a**).  
The **LOC/REM** key is disabled when a digital input is configured as a **Loc/Rem** selector switch (see **C180a**).

**C148** sets whether toggling between Remote mode and Local mode is activated only when the drive is disabled, or whether toggling from Remote to Local mode does not affect the drive running conditions (bumpless commands), but it does affect the reference. You can also choose to keep running conditions and reference unaffected (any command is bumpless). For more details, please refer to the description of parameter **C148** (CONTROL METHOD MENU).

In LOCAL mode (the L-CMD and L-REF LEDs come on), when drive references and commands are sent via display/keypad, the Keypad page allows changing the given reference using the ▲ and ▼ keys (see **P266** in the DISPLAY/KEYPAD menu).

When not in LOCAL mode, press the **MENU** key to access the Keypad pages from the root page. Only the Keypad pages relating to the Keypad source will be displayed along with the Measure Keypad page.

Example: Parameter **C147** (Torque Limit Reference Selection) is set to Keypad. From the root page, press the **MENU** key once to display the Measure Keypad page, and press the **MENU** key twice to display the Keypad page relating to the torque limit and allowing changing the torque limit reference using the ▲ and ▼ keys.

The Keypad page allows entering custom measures (see parameters **P268b** to **P268e** in the DISPLAY/KEYPAD menu).

From the Keypad pages, press the **SAVE/ENTER** key to access the Keypad Help page containing any details about the measures displayed in the Keypad page.

## 1.11. SAVE/ENTER Key

---

The **SAVE/ENTER** key allows selecting a lower level when navigating within the programming menus. It also allows changing a parameter value (to change a parameter value, press the **SAVE/ENTER** key from the page of the parameter you want to change). An example is given in Figure 2.

From the Keypad pages, the **SAVE/ENTER** key allows accessing the Keypad Help page containing any details about the measures displayed in the Keypad page.

## 1.12. Indicator LEDs on the Display/Keypad

Eleven LEDs are located on the keypad, along with a 4-line, 16-character LCD display, a buzzer and 12 function keys. The display shows the parameter values, the diagnostic messages and the variables processed by the drive. The figure below shows the location of the indicator LEDs and their functionality.

Figure 3: Display/keypad

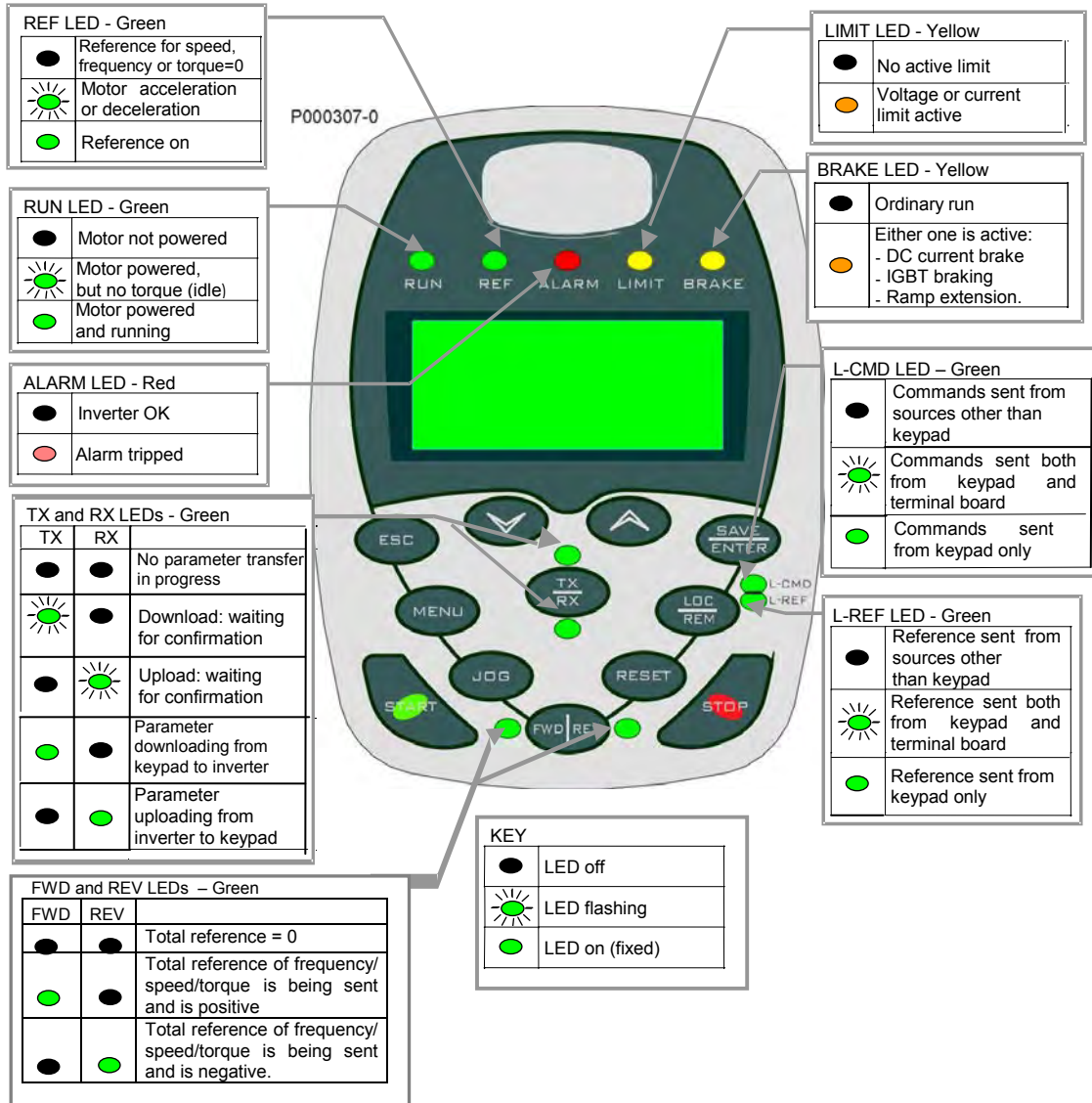

**NOTE**

See also the OPERATING AND REMOTING THE KEYPAD section in the Sinus Penta's Installation Guide.

## 2. DESCRIPTION OF INPUT AND OUTPUT SIGNALS

The control board of the drives of the Sinus Penta series is provided with the following inputs/outputs:

- **3 Analog Inputs** (single-ended REF input, differential AIN1 & AIN2 inputs) that can be programmed as voltage/current inputs via SW1 DIP-switch (see Configuration DIP-switches in the Sinus Penta's Installation Guide).
- **3 Analog Outputs** that can be programmed as voltage/current inputs via SW2 DIP-switch (see Configuration DIP-switches in the Sinus Penta's Installation Guide).
- **8 MDI Multifunction Digital Inputs**; 3 of them (MDI6, MDI7, MDI8) are fast-acquisition inputs allowing acquiring frequency signal or encoder signals.
- MDI6 can be used to acquire a frequency signal called FINA; if used in conjunction with MDI7, it also allows acquiring a push-pull encoder signal called Encoder A.
- MDI8 can be used to acquire a frequency input called FINB (this avoids acquiring encoder B via **ES836** or **ES913** optional board).
- **4 MDO Multifunction Digital Outputs**; MDO1 is a Push-pull output, MDO2 is an Open Collector output and MDO3-4 are relay outputs.



**NOTE** Relay digital output **MDO4** is allocated to the **Safe Torque Off (STO)** function and cannot be configured by the user.

Electrical ratings of the control board inputs/outputs are given in the Sinus Penta's Installation Guide.

When programming:

- **Analog Inputs**, see the INPUTS FOR REFERENCES MENU
- **Analog Outputs**, see the ANALOG AND FREQUENCY OUTPUTS MENU
- **Digital Inputs**, see the DIGITAL INPUTS MENU
- **Digital Inputs used as Frequency/Encoder Inputs**, see the ENCODER/FREQUENCY INPUTS MENU
- **Multifunction Digital Outputs**, see the DIGITAL OUTPUTS MENU



**CAUTION** The drive is factory-set with the REF input configured as 0-10V and AIN1-AIN2 inputs configured as 4-20mA.  
SW1 dip-switches, which are located on the control board, must be set as follows:

SW1

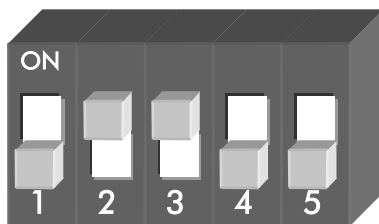

### 3. REFERENCES AND FEEDBACKS

The drive references are the following:

- Main speed/torque reference
- Speed/torque limit reference
- PID reference
- PID feedback

#### 3.1. Main Speed/Torque Reference

---

If a speed control (e.g. **C011 = Speed** for Motor 1) is used, the main reference is a speed reference, while if a torque control is used (e.g. **C011=Torque** or **C011=Speed** for Motor 1, but the digital input is closed for the Slave programmed with C170), the main reference of the drive is a torque reference.

The main reference can be one of the following:

- Analog/digital inputs programmed as sources (see parameters **C143-C146** in the CONTROL METHOD MENU)
- PID output if **C294 PID Action = Reference**
- Digital inputs programmed as Multispeed (see MULTISPEED MENU) only when the main reference is a speed reference.

#### 3.2. Speed/Torque Limit Reference

---

If a speed control is used (e.g. **C011 = Speed** for Motor 1) and a VTC or FOC algorithm is used, you can program a source as an external torque limit (see parameter **C147** in the CONTROL METHOD MENU).

If a torque control is used and an external speed limit has been set up (e.g. **C011 = Torque with Speed Limit** for Motor 1) and a FOC algorithm is used, you can program one source as an external speed limit (see parameter **C147** in the CONTROL METHOD MENU).

#### 3.3. PID Reference

---

If the internal PID regulator is enabled (**C291 different from Disabled**), its reference is given by default by the sum of the three sources programmed as references (see parameters **C285-C287** in the PID CONFIGURATION MENU).

Different types of PID reference control (Two PIDs and 2-zone mode) are available based on the setting in parameter **C291a** (PID Control Mode).

#### 3.4. PID Feedback Reference

---

The PID feedback by default is the sum of the three sources programmed as feedback (see parameters **C288-C290** in the PID CONFIGURATION MENU).

Different types of PID feedback control (Two PIDs and 2-zone mode) are available based on the setting in parameter **C291a** (PID Control Mode).

## 4. PROGRAMMABLE FUNCTIONS

### 4.1. Multimotor

---

The Sinus Penta drive provides 3 separate sets of parameters allowing configuring three control algorithms for 3 types of motors:

- **C009** Number of configured motors =2
- **C173** Digital input for Motor 2 = MDI6

When MDI6 is open, the parameters relating to Motor 1 are used for the motor control; when MDI6 is closed, the parameters relating to Motor 2 are used for the motor control (see the MOTOR CONFIGURATION MENU and the MULTISPEED MENU).

### 4.2. Voltage/Frequency Pattern

---

When using a Volt/Freq IFD control algorithm (e.g. **C010 = V/F IFD** for Motor 1), you can select different types of V/f patterns (see the V/f Pattern (IFD Only) section in the MOTOR CONFIGURATION MENU).

### 4.3. Slip Compensation

---

When using a Volt/Freq IFD control algorithm (e.g. **C010 = V/F IFD** for Motor 1), you can set the slip compensation function for a more accurate speed control (see the Slip Compensation (IFD Only) section in the MOTOR CONFIGURATION MENU).

### 4.4. Speed Searching

---

When using a Volt/Freq IFD control algorithm (e.g. **C010 = V/F IFD** for Motor 1), you can set the speed searching function for the motor speed of rotation, which is useful when the drive controls a motor which is already running (as for motors connected to fans). See the SPEED SEARCHING MENU for more details.

### 4.5. Controlled Stop in Case of Power Failure (Power Down)

---

See the POWER DOWN MENU to set a controlled stop in case of power failure.

### 4.6. DC Braking

---

When using a Volt/Freq IFD or Vector Torque VTC control algorithm, you can set DC braking at start or at stop. The DCB Hold function can be set for the Volt/Freq IFD function. See the DC BRAKING MENU for more details.

### 4.7. Motor Thermal Protection

---

The Motor Thermal Protection function protects the motor against possible overloads. This function can be obtained via a PTC acquired in AIN2 analog input—up to 6 PTCs can be series-connected—or it can be a software protection implemented through an algorithm reproducing the motor thermal image.

See the MOTOR THERMAL PROTECTION MENU for more details.

For more details about using AIN2 input, please refer to the Sinus Penta's Installation Guide.

## 4.8. Prohibit Speeds

---

Prohibit speeds are speed ranges corresponding to mechanical resonance frequencies. They prevent the drive from running at the preset speed ranges.

See the PROHIBIT SPEED MENU for more details.

## 4.9. Digital PID Regulator

---

The Sinus Penta drive is provided with a digital PID (proportional, integral, derivative) regulator that can be used to implement the following:

- Analog output
- Main reference of the drive (Speed/Torque reference)
- Correction of the main reference
- Correction of the output voltage (only for Volt/Freq IFD control)

See the PID PARAMETERS MENU and the PID CONFIGURATION MENU for more details.

## 4.10. Bridge Crane Application

---

For lifting applications, such as a bridge crane, it may be useful to consider the actual time required to release the safety electromechanical brake (the delay between the electrical command and the actual opening of the brake) and the closure of the electromechanical brake.

For a detailed description of the benefits offered by the parameters relating to lifting applications, see the BRIDGE CRANE MENU.

## 4.11. Setting Two Alternative Command Sources and Reference Sources

---

You can set a digital input as a selector switch allowing selecting two alternative control sources and reference sources.

Example:

A selector switch is required to select **control mode B** (the drive references and commands are sent via fieldbus) and **control mode A** (the drive reference is sent via AIN1 analog input and commands are sent via keypad).

The following parameters shall be set up accordingly:

**C179** MDI for source selection= **MDI6**

**C140** Selection of control source n. 1 = **Keypad**

**C141** Selection of control source n. 2 = **Fieldbus**

**C143** Selection of reference n. 1 = **AIN1**

**C144** Selection of reference n. 2 = **Fieldbus**

When MDI6 digital input in the terminal board is open (terminal 19), the command sources and reference sources n. 1 are selected (Keypad and AIN1 analog input, control mode A). When MDI6 is closed, the command sources and reference sources n. 2 are selected (Fieldbus, control mode B).



### CAUTION

In the example above, if **C179 = Disable**, the OR logic for the Keypad and Fieldbus is considered, whereas the Fieldbus and AIN1 control sources are considered as summed up.

See also parameter **C179** in the DIGITAL INPUTS MENU.

## 4.12. Fire Mode

---

When the digital input programmed as FIRE MODE is activated, all the protecting functions of the drive are ignored, so that no alarm trips when the drive is operating.



### CAUTION

The Fire Mode function must be used only when it is strictly necessary, such as in fire pumps, to protect human lives. This function must never be used to prevent alarms from tripping in domestic or industrial applications.



### NOTE

To activate the parameters relating to the Fire Mode, enter the Password in the PRODUCT MENU .

This Password is provided by Elettronica Santerno's Service Department. The drive Serial Number is required (see the Serial Number parameter in the PRODUCT MENU ).

The following parameters can be accessed only after entering the Password enabling the Fire Mode:

- **P032** Acceleration Ramp in Fire Mode (see the RAMPS MENU)
- **P033** Deceleration Ramp in Fire Mode (see the RAMPS MENU)
- **P099** Speed Fire Mode (see the MULTISPEED MENU)
- **C186** MDI Enabling Fire Mode (see the DIGITAL INPUTS MENU)

The Fire Mode is enabled when closing the MDI set through **C186**. The drive will use the speed reference set in **P099** and the ramp times set in **P032**, **P033**. All alarms will be ignored, except for the following:

|             |                   |   |
|-------------|-------------------|---|
| <b>A041</b> | IGBT FAULT Side A | IGBT Hardware Side A, general alarm           |
| <b>A044</b> | OVERLOAD SW       | Software Overcurrent                          |
| <b>A048</b> | OVER VOLTAGE      | DC-bus voltage exceeding Vdc_max              |
| <b>A050</b> | IGBT FAULT A      | Hardware Fault from IGBT Drive, side A        |
| <b>A051</b> | OVERLOAD HW A     | Hardware Overcurrent, side A                  |
| <b>A053</b> | PWMA Not ON       | Hardware Failure, Side A IGBT cannot be fired |
|             |                   | <i>Control Board Failure</i>                  |

When the Fire Mode is active, innumerable alarm autoresets are automatically enabled.



### CAUTION

If an asterisk (\*) appears next to **INVERTER OK** on the display, the product guarantee is no longer valid.

The asterisk appears if at least one condition requiring the activation of a protection feature occurs when the inverter is running in Fire Mode.

## 5. PROGRAMMING EXAMPLES

### 5.1. Overview

---

This section illustrates some programming examples for particular functions of the Penta drive. Flowcharts are used for easier reference.

For any detail concerning individual parameters, see the relevant sections in this manual.

### 5.2. Programming a Reference

---

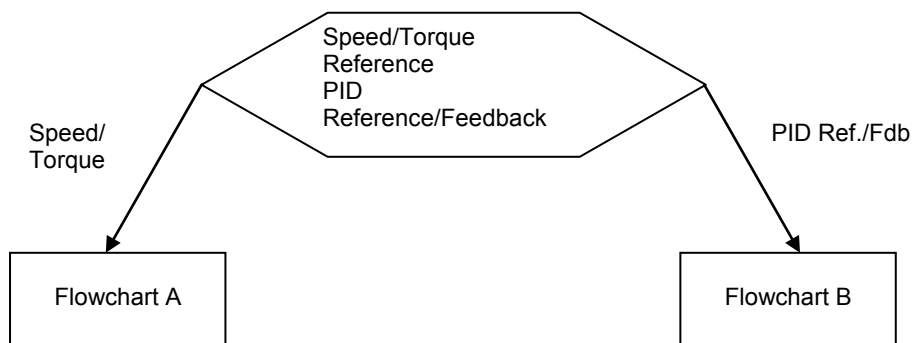

**FLOWCHART A**

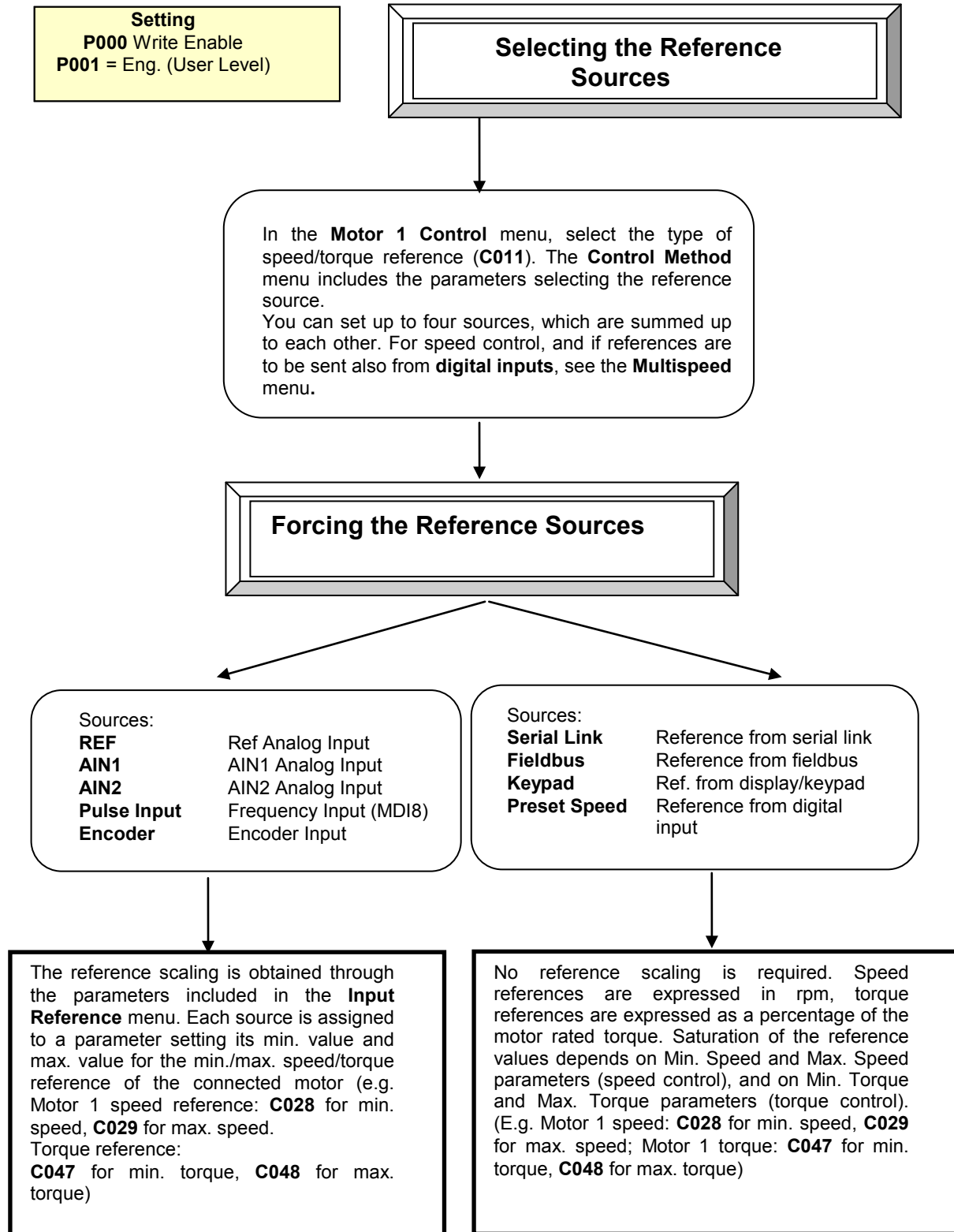

**FLOWCHART B**

**Setting**  
**P000** Write Enable  
**P001** = Eng. (User Level)

**Selecting the Ref/Feedback Sources**

The **PID Configuration** menu includes the parameters selecting the reference/feedback source. You can set up to three sources, which are summed up to each other.

**Forcing the Reference/Feedback Sources**

Sources:

|                    |                        |
|--------------------|------------------------|
| <b>REF</b>         | Ref Analog Input       |
| <b>AIN1</b>        | AIN1 Analog Input      |
| <b>AIN2</b>        | AIN2 Analog Input      |
| <b>Pulse Input</b> | Frequency Input (MDI8) |
| <b>Encoder</b>     | Encoder Input          |

Sources:

|                           |                            |
|---------------------------|----------------------------|
| <b>Serial Link</b>        | Reference from serial link |
| <b>Fieldbus</b>           | Reference from fieldbus    |
| <b>Keypad</b>             | Ref. from display/keypad   |
| Feedback reference only : |                            |
| <b>Iout</b>               | Output current             |
| <b>Vout</b>               | Output voltage             |
| <b>Vdc</b>                | DC bus voltage             |
| <b>Pout</b>               | Output power               |

The reference scaling is obtained through the parameters included in the **Reference** menu. Each source is assigned to a parameter setting its min. value and max. value for the min./max. PID Reference/Feedback value. See the **PID Parameters** menu.  
 Reference      **P245** Min., **P246** Max.  
 Feedback      **P247** Min., **P248** Max.

No reference scaling is required. References are expressed as a percentage. As a feedback reference, output current (Iout), output voltage (Vout), DC bus voltage (Vdc) are available, which refer (as full-scale values) to the following:  
 Rated current of the selected motor (Mot.1 **C018**)  
 Rated voltage of the selected motor (Mot.1 **C019**)  
 DCb Bus 1500 V.

**EXAMPLE:**

The speed of a motor is to be controlled via a 0 ÷ 5 V analog input. Speed range is 0 ÷ 1500 rpm; two digital inputs are available to increase three speed values with steps of 100rpm.

**Setting the min. and max. speed:**

The parameters for the motor min./max. speed are **C028** = 0 rpm, **C029** = 1800 rpm.

**Setting the analog reference:**

Default setting: the analog reference is sent from REF input (**C143** = REF).

The speed range for the analog input must be 0 ÷ 1500 rpm.

Default setting in the INPUTS FOR REFERENCES MENU for REF analog input:

**P050** = 3: 0 –10 V           Type of reference for REF input  
**P051** = 0.0 V               Min. value for REF input  
**P052** = 10.0 V              Max. value for REF input

**P052** is the voltage value for REF input for a speed reference of 1800rpm (**C029**)

For a speed reference of 1500rpm with 5 V, **P052** is to be set as follows:

(Max. speed REF): (5 V) = (**C029**): (Vx)

$$Vx = 5 V * 1800rpm / 1500rpm = 6 V$$

If **P052** = 6V, a speed reference of 1500rpm is set for REF with 5V.

**Setting the reference from digital inputs:**

Default setting: two digital inputs for multispeed values.

Digital Inputs Menu: **C155** = MDI4; **C156** = MDI5

Depending on the status of digital inputs MDI4 and MDI5:

| MDI4 | MDI5 | Multispeed |
|------|------|------------|
| 0    | 0    | 0          |
| 1    | 0    | 1          |
| 0    | 1    | 2          |
| 1    | 1    | 3          |

In the MULTISPEED MENU, set the speed steps as follows:

**P080** = 1: Sum Speed  
**P081** = 100rpm Multispeed 1  
**P083** = 200rpm Multispeed 2  
**P085** = 300rpm Multispeed 3

**P080** → Multispeed function: the selected multispeed is summed up to the reference for the analog input.

**P081, P083, P085** are the steps depending on the selected multispeed for digital inputs MDI4, MDI5.

### 5.3. Configuring the External Torque Limit

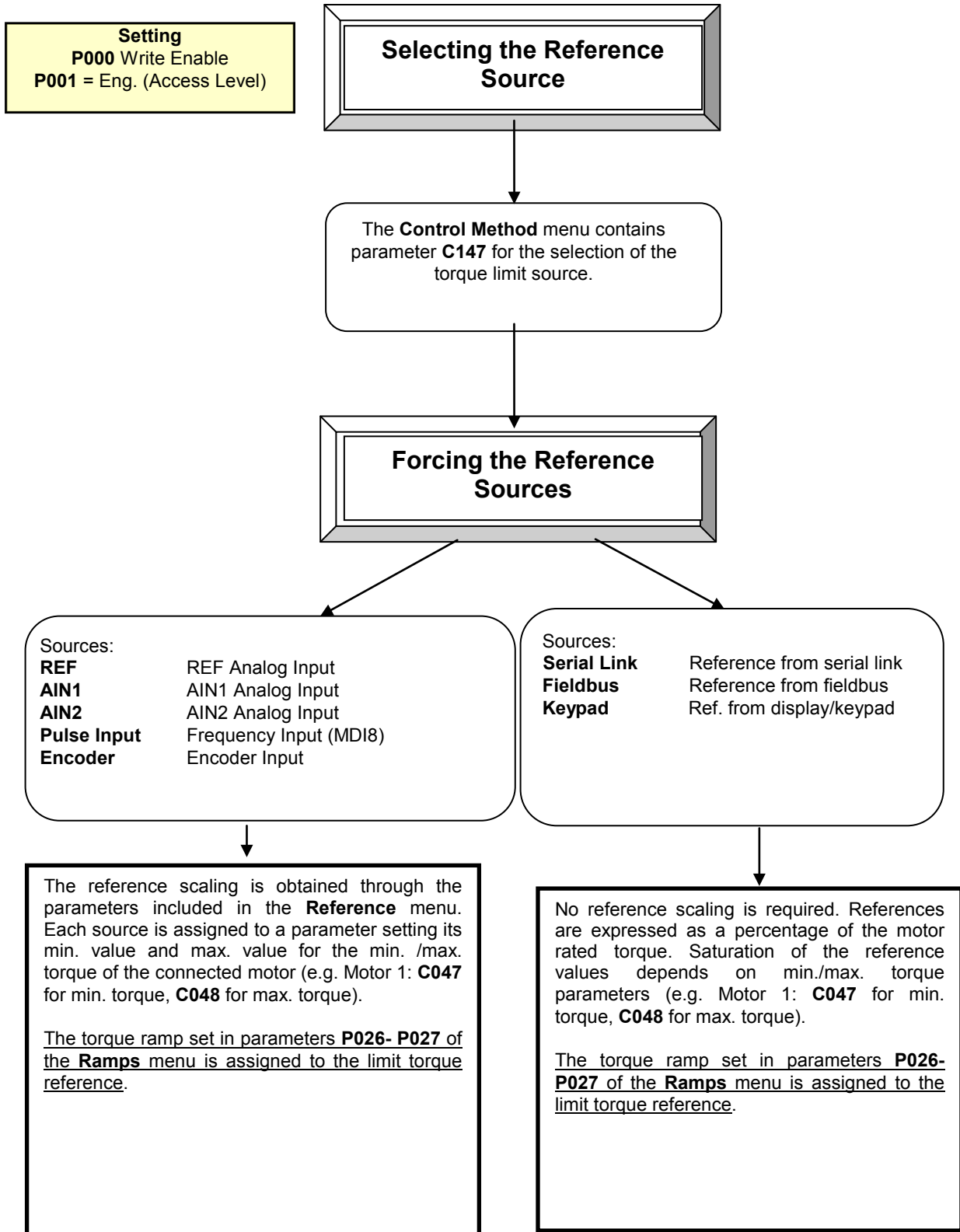

## 5.4. Configuring the Feedback from Incremental Encoder

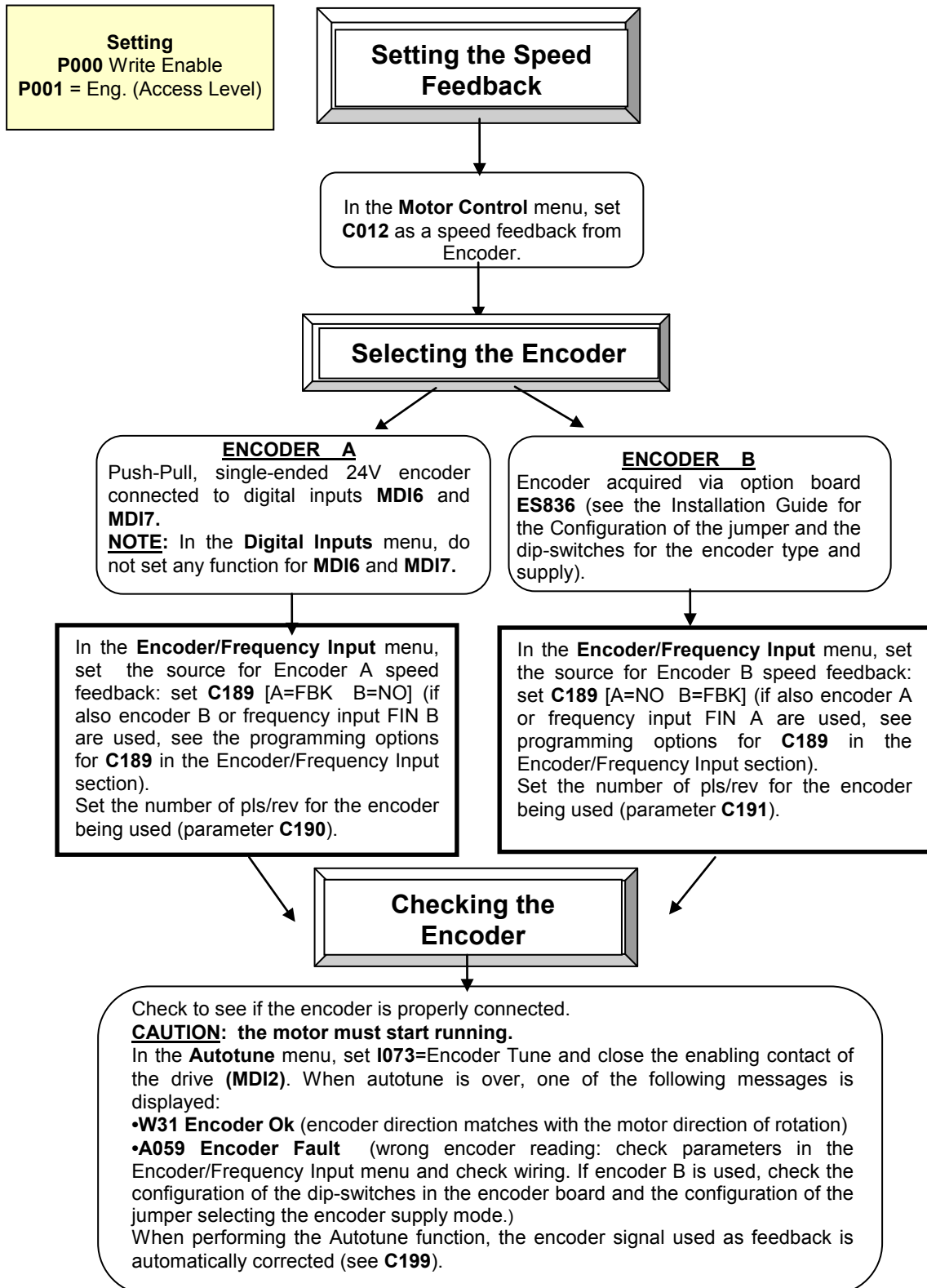

### 5.5. Configuring a Reference from Incremental Encoder

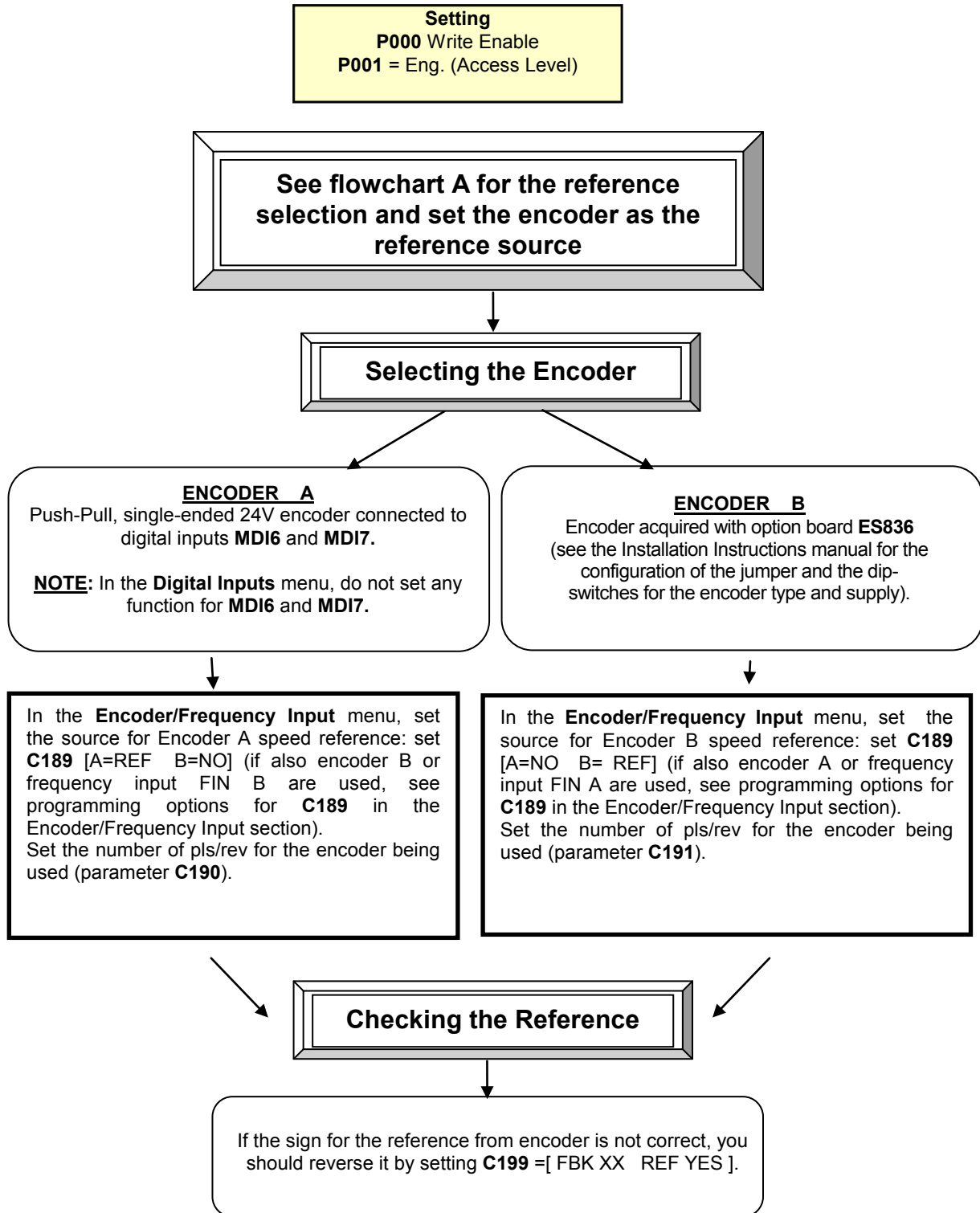

## 6. START-UP MENU

### 6.1. Overview

---

For easier startup of the Penta drive, you can activate the Start-Up Menu. The Start-Up Menu is a wizard allowing programming the main parameters for the connected motor and the parameters for PID control. The parameters in this menu are the same as described in the FIRST STARTUP section.

The Start-Up Menu is displayed when the Penta drive is first started. The Start-Up Menu can be reactivated at any time. To do so, set **P265** in “Start Up” mode (see the DISPLAY/KEYPAD MENU) and power on the Penta drive again.

The following is the root page of the Start-Up menu:

```
[ I D P ] S I N U S   P E N T A
S T A R T - U P   M E N U
P r e s s   E N T E R
t o   s t a r t
```

Press **ENTER** to enter the wizard.

Before entering the control parameters, you are asked to choose a dialogue language:

```
P 2 6 3   L a n g u a g e
→@@@@@@@@@@@@@@@@@
```

then you are asked to choose the display mode of the Start Up Menu:

```
W h e n   d o e s   t h e
S t a r t - U p   M e n u
a c t i v a t e ?
→@@@@@@@@@@@@@@@@@
```

Choose one of the following:

```
1 : E V E R Y   S T A R T - U P
2 : O N L Y   N O W
3 : N E X T   S T A R T - U P
4 : N E V E R
```

If you select “EVERY START-UP”, the wizard appears whenever the Penta drive is powered on;  
if you select “ONLY NOW”, you can scroll through the menu and the wizard is disabled as soon as you quit the menu;  
if you select “NEXT START-UP”, the menu is displayed only when the Penta drive is next started up;  
if you select “NEVER”, the Start-Up menu is disabled.

Parameters included in the Start-Up menu:

| Parameter | Description                      | Visibility                     |
|-----------|----------------------------------|--------------------------------|
| C008      | Rated mains voltage              |                                |
| C010      | Type of control algorithm        |                                |
| C012      | Speed feedback from encoder      | [only if FOC is active]        |
| C013      | Type of V/f pattern              | [only if IFD is active]        |
| C015      | Rated motor frequency            |                                |
| C016      | Rated motor rpm                  |                                |
| C017      | Rated motor power                |                                |
| C018      | Rated motor current              |                                |
| C019      | Rated motor voltage              |                                |
| C021      | No-load current of the motor     | [only if FOC is active]        |
| C028      | Min. motor speed                 |                                |
| C029      | Max. motor speed                 |                                |
| C034      | Voltage preboost                 | [only if IFD is active]        |
| P009      | Acceleration ramp time           |                                |
| P010      | Deceleration ramp time           |                                |
| C043      | Current limit while accelerating | [only if IFD is active]        |
| C044      | Current limit at constant rpm    | [only if IFD is active]        |
| C045      | Current limit while decelerating | [only if IFD is active]        |
| C048      | Torque limit                     | [only if VTC/FOC are active]   |
| C189      | Encoder operating mode           | [only if FOC is active]        |
| C190      | Encoder A pls/rev                | [only if FOC is active]        |
| C191      | Encoder B pls/rev                | [only if FOC is active]        |
| I073      | Autotuning selection             | [only if VTC/FOC are active]   |
| I074      | Motor tuning selection           | [only if VTC/FOC are active]   |
| C265      | Motor thermal protection         |                                |
| C267      | Motor thermal time constant      | [only if protection is active] |

After setting the last parameter and moving the cursor forward, the following page will appear:

**P r e s s   U P   A R R O W**  
**t o   q u i t**  
**D O W N   A R R O W**  
**t o   c o n t i n u e**

Press ▲ to quit the Start-up menu. The default page of the system will be displayed.

## 7. FIRST STARTUP

For the signal wiring and power wiring, please refer to the Sinus Penta's Installation Guide. Parameter programming is detailed in the START-UP MENU.

### 7.1. "IFD" Control Algorithm

---

SINUS PENTA drives are factory set with the IFD (**C010**) control algorithm for the first startup of the equipment. The default functions of the drive terminals are given in the table below. For more details, please refer to the Sinus Penta's Installation Guide.

- 1) Wiring:** Follow the instructions stated in the "Caution Statements" and "Installation" sections (Installation Guide).
- 2) Power on:** Power on the drive and do not close the link to the **ENABLE-A** and **ENABLE-B** inputs to prevent the motor from running. Check if the display/keypad turns on.
- 3) Parameter setting:** The equipment startup is made easier by the START-UP MENU, which is a wizard for the set up of the main motor control parameters.

From the START-UP MENU, set the following:

1. The real power supply voltage in **C008**. It is possible to select the rated mains voltage range or the power supply from a DC-bus stabilized by a Regenerative Penta;
2. The motor ratings by way of:
  - **C015** (fmot1) rated frequency
  - **C016** (rpmnom1) rated rpm
  - **C017** (Pmot1) rated power
  - **C018** (Imot1) rated current
  - **C019** (Vmot1) rated voltage
  - **C029** (Speedmax1) max. allowable speed.

The motor V/f pattern may be programmed in **C013**. For loads with quadratic torque in respect to the rpm (centrifugal pumps, fans, etc.), set **C034** (preboost1) to 0%.

- 4) Autotune::** **For the IFD control algorithm, the Autotune function is not necessary but is always recommended.**

With the **ENABLE-A** and **ENABLE-B** commands open, access the AUTOTUNE MENU and set **I073** = [1: Motor Tune] and **I074** = [0: All Ctrl no rotation]. Use the **ESC** key to accept changes.

Close the **ENABLE-A** and **ENABLE-B** commands and wait until tune is complete (Warning "**W32** Open Enable" is displayed). The drive has computed and saved the values for **C022** (stator resistance) and **C023** (leakage inductance).

If alarm "**A097** Motor Wires KO" trips, check the motor wiring. If alarm "**A065** Autotune KO" trips, this means that the **ENABLE** command has opened before autotune was complete. In this case, reset the drive sending a command from terminal MDI3, or press the **RESET** key in the display/keypad and perform the autotune procedure again.

- 5) Overload:** Set parameters **C043**, **C044** and **C045** as the maximum desired overload current.

- 6) Startup:** Activate the **ENABLE-A** input (terminal 15), **ENABLE-B** input (terminal S) and the **START** input (terminal 14) and send a speed reference: the **RUN** LED and **REF** LEDs will come on and the motor will start running. Make sure that the motor is rotating in the correct direction. If not, set parameter **C014** (Phase Rotation) to [1:Yes], or open the **ENABLE-A**, **ENABLE-B** and **START** inputs, remove voltage from the drive and, after waiting at least 20 minutes, swap two of the motor phases.

**7) Possible failures:** If no failure occurred, go to step 8. Otherwise, check the drive connections paying particular attention to supply voltages, DC link and input reference. Also check if alarm messages are displayed. In the MEASURES MENU, check the reference speed (**M001**), the supply voltage to the control section (**M030**), the DC link voltage (**M029**), and the condition of control terminals (**M033**). Check to see if these readouts match with the measured values.

**8) Additional parameter modifications:** When parameter **P003** = Standby Only (condition required for changing C parameters), you can change **Cxxx** parameters in the CONFIGURATION menu only when the drive is DISABLED or STOPPED, whereas if **P003** = Standby + Fluxing, you can change **Cxxx** parameters when the motor is stopped but the drive is enabled.

You can write down any custom parameters in the table provided on the last pages of this Programming Guide (CUSTOM PARAMETERS).

**9) Reset:** If an alarm trips, find the cause responsible for the alarm and reset the drive. Enable input MDI3 (terminal 16) for some time, or press the **RESET** key on the display/keypad.



**NOTE** When the IFD control algorithm is used, only speed references can be set up.



**NOTE** The **ENABLE-A** and **ENABLE-B** inputs are allocated to the STO function. If this safety functionality is to be adopted, the control mode and the control circuit of these signals must be accomplished as per the Safe Torque Off Function - Application Manual.

That manual also includes a detailed validation procedure of the control configuration of the STO function to be executed upon first start-up and also periodically at yearly intervals.

## 7.2. “VTC” Control Algorithm

---

- 1) Wiring:** Follow the instructions stated in the “Caution Statements” and “Installation” sections in the Sinus Penta’s Installation Guide.
- 2) Power on:** Power on the drive and do not close the link to the **ENABLE-A** and **ENABLE-B** inputs to prevent the motor from running. Check if the display/keypad turns on.
- 3) Parameter setting:** The equipment startup is made easier by the START-UP MENU, which is a wizard for the setup of the main motor control parameters.

From the START-UP MENU, set the following:

1. The real power supply voltage in **C008**. It is possible to select the rated mains voltage range or the power supply from a DC-bus stabilized by a Regenerative Penta;
2. The control algorithm as VTC (Vector Torque Control) in **C010**;
3. The motor ratings by way of:
  - **C015** (fmot1) rated frequency
  - **C016** (rpmnom1) rated rpm
  - **C017** (Pmot1) rated power
  - **C018** (Imot1) rated current
  - **C019** (Vmot1) rated voltage
  - **C029** (Speedmax1) max. allowable speed.

---

**CAUTION:** It is not advisable to set rated motor power and current lower than 50% of the drive size. This would adversely affect the motor control performance.

If the no-load current of the motor is known, set **C021** ( $I_0$ ) with the  $I_0$  value expressed as a percentage of the rated motor current.

If the no-load current of the motor is not known but the motor can rotate freely without any connected load, start the motor in IFD mode at nominal rpm, read out the current value from the Motor Measures Menu (**M026**) and use it as a first trial value for  $I_0$ .

Then, if known, set **C022** (resistance of one stator phase for a star connection or one third of the phase resistance for a delta connection) and **C023** (stator leakage inductance of one phase, for a star connection, or one third of that of one phase for a delta connection). **C022** is half the resistance value measured with an ohmmeter between two of the motor phases.

If the values to be set for **C022** and **C023** are not known, perform the motor autotune procedure (see step 4) or go to step 5. Press **SAVE/ENTER** to store a parameter each time it has been changed.

- 4) Autotune for stator resistance and leakage reactor:** With the **ENABLE-A** and **ENABLE-B** commands open, access the AUTOTUNE MENU and set **I073** = [1: Motor Tune] and **I074** = [0: All Ctrl no rotation]. Press **ESC** to confirm the new values.

Close the **ENABLE-A** and **ENABLE-B** commands and wait until tune is complete (Warning “**W32** Open Enable” is displayed). The drive has computed and saved the values for **C022** (stator resistance) and **C023** (leakage inductance).

If alarm “**A097** Motor Wires KO” trips, check the motor wiring. If alarm “**A065** Autotune KO” trips, this means that the **ENABLE-A** and **ENABLE-B** commands have opened before autotune was complete. In that case, reset the drive sending a command from terminal MDI3, or press the **RESET** key in the display/keypad and perform the autotune procedure again.

- 5) Autotune for rotor time constant and current loop:** With the **ENABLE-A** and **ENABLE-B** commands open, access the AUTOTUNE MENU and set **I073** = [1: Motor Tune] and **I074** = [1: FOC (VTC) Auto no rot]. Press **ESC** to confirm the new values. Close the **ENABLE-A** and **ENABLE-B** commands and wait until tune is complete (Warning “**W32** Open Enable” is displayed).

If alarm “**A065** Autotune KO” trips, this means that the **ENABLE-A** and **ENABLE-B** commands have opened before autotune was complete or the autotune algorithm has failed within the preset timeout. In that case, reset the drive sending a command from terminal MDI3, or press the **RESET** key in the display/keypad and perform the autotune procedure again.

At the end of the autotune procedure, the system will have computed the FOC current loop (useful for the following steps) and parameter **C024** (mutual inductance).

If the motor can rotate with no connected load, do the following to estimate the rotor time constant: access the AUTOTUNE MENU and set **I073**= [1: Motor Tune] and **I074**= [2: FOC/VTC Auto+rot (tau)]. Press **ESC** to confirm changes. Close the **ENABLE-A**, **ENABLE-B** and **START** commands and wait until tune is complete (Warning “**W32** Open Enable” is displayed). The system has now computed and saved the values in **C025** (Rotor Time Constant), **P175r1**, **P175s1**, **P175t1**, **P175u1**, **P175v1** (current regulator parameters). If alarm “**A065** Autotune KO” trips, this means either that the **ENABLE-A** and **ENABLE-B** commands have opened before autotune was complete, or that the available timeout has elapsed. In either case, reset the drive sending a command from terminal MDI3, or press the **RESET** key on the display/keypad and perform the autotune procedure again.

If the motor cannot rotate with any connected load, only perform the current loop autotune procedure by accessing the AUTOTUNE MENU and by setting **I073** = [1: Motor Tune] and **I074** = [6: VTC Auto no rot].

In that way, **C024** (rotor time constant) is set to an estimated value, while the system computes and saves the current regulator parameters (**P175r1**, **P175s1**, **P175t1**, **P175u1**, **P175v1**).

If alarm “**A065** Autotune KO” trips, this means either that the **ENABLE-A** and **ENABLE-B** commands have opened before autotune was complete, or that the available timeout has elapsed. In either case, reset the drive sending a command from terminal MDI3, or press the **RESET** key on the display/keypad and perform the autotune procedure again.

- 6) Overload:** Set parameter **C048** in the LIMITS MENU based on the maximum torque that can be generated expressed as a percentage of the motor rated torque.
- 7) Startup:** Activate the **ENABLE-A** input (terminal 15), **ENABLE-B** (terminal S) and the **START** input (terminal 14) and send a speed reference. The **RUN** LED and **REF** LED will come on and the motor will start. Make sure that the motor is rotating in the correct direction. If not, set parameter **C014** (Phase Rotation) = [1:Yes], or open the **ENABLE-A**, **ENABLE-B** and **START** inputs, remove voltage from the drive and, after waiting at least 20 minutes, swap two of the motor phases.
- 8) Speed regulator adjustment:** If overshoot occurs when the speed setpoint is attained or if a system instability is detected (jerking), adjust the parameters relating to the speed loop (SPEED LOOP AND CURRENT BALANCING MENU). Set the two parameters relating to integral time (**P125**, **P126**) as [Disabled] and set low values for the parameters relating to proportional gain (**P127**, **P128**). Set equal values for **P127** and **P128** and increase them equally until overshoot takes place when the setpoint is attained. Decrease **P127** and **P128** by approx. 30%, then decrease the high values set for integral time in **P125** and **P126** (keep both values equal) until an acceptable setpoint response is obtained. Check to see if the motor runs smoothly at constant speed.
- 9) Possible failures:** If no failure occurred, go to step 10. Otherwise, check the drive connections paying particular attention to supply voltages, DC link and input reference. Also check if alarm messages are displayed. In the MEASURES MENU, check the reference speed (**M000**), the reference speed processed by the ramps (**M002**), the supply voltage of the control section (**M030**), the DC-link voltage (**M029**), the condition of the control terminals (**M033**). Check to see if these readouts match with the measured values.

Decrease the value set for **C022** if the motor is not able to start or if oscillations occur when the motor is rotating at low speed and with no connected load.

When low-speed operation failures occur, such as oscillations or difficulty in keeping the reference speed, decrease the flux boost (**P175h1**) at low frequency. The flux boost is usually increased for steady control when the motor is not rotating or is rotating at low frequency, but can have adverse effects based on the type of motor being used.

In the event of heavy oscillations at high power (i.e. at high speed with high torque demand) it is recommended that the flux feedback gain in the current loop (**P175v1**) be decreased.

In the event of jerky control, it is recommended that the current loop proportional gain (**P175t1**) be decreased; if required, increase the integral time constant (**P175u1**).

**10) Additional parameter modifications:** When parameter **P003** = Standby Only (condition required for changing **Cxxx** parameters), you can change **Cxxx** parameters only when the drive is DISABLED or STOPPED, whereas if **P003** = Standby + Fluxing, you can change **Cxxx** parameters when the motor is stopped but the drive is enabled.

Before changing any parameters, remember that the correct code for parameter **P000** must be previously set up.

You can write down any custom parameters in the table provided on the last pages of this Programming Manual (CUSTOM PARAMETERS).

**11) Reset:** If an alarm trips, find the cause responsible for the alarm and reset the drive. Enable input MDI3 (terminal 16) for some time, or press the **RESET** key on the display/keypad.

**NOTE**

The **ENABLE-A** and **ENABLE-B** inputs are allocated to the STO function. If this safety functionality is to be adopted, the control mode and the control circuit of these signals must be accomplished as per the Safe Torque Off Function - Application Manual. That manual also includes a detailed validation procedure of the control configuration of the STO function to be executed upon first start-up and also periodically at yearly intervals.

### 7.3. “FOC” Motor Control

---

- 1) Wiring:** Follow the instructions stated in the “Caution Statements” and “Installation” sections in the Sinus Penta’s Installation Guide.
- 2) Power on:** Power on the drive and do not close the link to the **ENABLE-A** and **ENABLE-B** inputs to prevent the motor from running. Check to see if the display/keypad turns on.
- 3) Parameter setting:** The equipment startup is made easier by the START-UP MENU, which is a wizard for the set up of the main motor control parameters.
- From the START-UP MENU, set the following:
1. The real power supply voltage in **C008**. It is possible to select the rated mains voltage range or the power supply from a DC-bus stabilized by a Regenerative Penta;
  2. Control algorithm as FOC (Field Oriented Control) in **C010**;
  3. The motor ratings by way of:
    - **C015** (fmot1) rated frequency
    - **C016** (rpmnom1) rated rpm
    - **C017** (Pmot1) rated power
    - **C018** (Imot1) rated current
    - **C019** (Vmot1) rated voltage
    - **C029** (Speedmax1) max. allowable speed.

---

**CAUTION:** It is not advisable to set rated motor power and current lower than 50% of the drive size. This would adversely affect the motor control performance.

If the no-load current of the motor is known, set **C021** ( $I_0$ ) with the  $I_0$  value expressed as a percentage of the rated motor current.

If the no-load current of the motor is not known but the motor can rotate freely without any connected load, start the motor in IFD control at nominal rpm, read out the current value from the Motor Measures Menu (**M026**) and use it as a first trial value for  $I_0$ .

---

**NOTE** If the connected motor must run at a higher speed than its rated speed (flux weakening), measure the no-load current value of the motor at its rated speed, not at its max. speed.

If the no-load current of the motor is not known and the motor cannot run in no-load conditions, use a first trial value for  $I_0$  that is automatically computed by the drive, as described in step 5.

---

**NOTE** When parameter **C021** ( $I_0$ ) = 0, the drive will automatically set a value depending on the motor ratings whenever the motor autotune (step 5) is performed.

---

Once a no-load current value is entered in **C021**, the value of the parameter relating to mutual inductance (**C024**) will be automatically computed when parameters **I073**= [1: Motor Tune] and **I074**= [1: FOC Auto no rotation] are set up (**C024** is computed even if no autotune procedure occurs).

- 4) Encoder Test:** **The motor must run when testing the encoder.**
- Set the source of the encoder signal used as a speed feedback (Encoder A in terminal board, Encoder B from ES836 or ES913 optional board) in parameter **C189**; enter the number of pulse/rev (**C190** or **C191**).
- Set the parameter relating to speed feedback from encoder: **C012** = Yes.
- With the **ENABLE-A** and **ENABLE-B** commands open, access the AUTOTUNE MENU and set parameter **I073**= [2: Encoder Tune]. Use the **ESC** key to confirm changes. Close the **ENABLE-A** and **ENABLE-B** commands and wait until encoder tune is complete (“**W32** Open Enable” is displayed).
- Once encoder tune is complete, the display will show one of the following messages:
- “**W31** Encoder Ok”; the speed feedback is correct. If the speed detected by the encoder is opposite to the desired speed, the drive will automatically reverse the feedback sign (parameter **C199**).
- “**A059** Encoder Fault”; the speed detected from the encoder is not consistent with the control speed. Possible causes:
- Wrong number of pls/rev of the encoder
  - Wrong power supply of the Encoder (e.g. +5V instead of +24V): check the encoder ratings and

the position of jumpers and DIP-switches for the encoder supply in the optional encoder board

- Wrong configuration of the DIP-switches for the encoder selection (push-pull or line-driver encoder) in the optional encoder board
- No connection to the encoder channel (check wiring)
- At least one Encoder channel is faulty (replace the encoder).

**5) Autotune of the stator resistance and leakage inductance:** With the **ENABLE-A** and **ENABLE-B** commands open, access the AUTOTUNE MENU and set **I073** = [1: Motor Tune] and **I074** = [0: All Ctrl no rotation]. Use the **ESC** key to accept changes. Close the **ENABLE-A** and **ENABLE-B** commands and wait until autotune is complete (warning "W32 Open Enable" is displayed). The drive has computed and saved the values for **C022** (stator resistance), **C023** (leakage inductance), **C021** ( $I_0$ ) if it was at 0% in step 3 and **C025** (tau) as the first trial value. If alarm "A097 Motor Wires KO" trips, check the motor wiring. If alarm "A065 Autotune KO" trips, this means that the **ENABLE-A** and **ENABLE-B** commands have opened before autotune was complete. In this case, reset the drive sending a command from terminal MDI3, or press the **RESET** key in the display/keypad and perform the autotune procedure again.

**6) Autotune of the current loop and flux loop:** With the **ENABLE-A** and **ENABLE-B** commands open, access the AUTOTUNE MENU and set **I073** = [1: Motor Tune] and **I074** = [1: FOC Auto no rotation]. Use the **ESC** key to accept changes. Close the **ENABLE-A** and **ENABLE-B** commands and wait until autotune is complete (warning "W32 Open Enable" is displayed). The drive has computed and saved the values in the FOC REGULATORS MENU (**P155** kp gain and **P156** integral time  $T_i$  of the current loop and flux loop). If alarm "A065 Autotune KO" trips, this means that the **ENABLE-A** and **ENABLE-B** commands have opened before autotune was completed or that the autotune algorithm has failed. In this case, reset the drive sending a command from terminal MDI3, or press the **RESET** key in the display/keypad and perform the autotune procedure again.

---

**NOTE:** If the **ENABLE-A** and **ENABLE-B** commands were not opened before autotune was over, decrease by 5% the no-load current value set in **C021** and perform autotune again.

---

**7) Tuning the mutual inductance and the rotor time constant:** **CAUTION:** For this autotune procedure, the motor must be free to rotate with no connected load. If the motor cannot start running with any connected load, the drive will automatically save a first trial value for the rotor time constant based on the motor ratings when performing autotune described in step 5.

The rotor time constant (**C025**) is estimated with a special autotune procedure allowing the motor to run even in no-load conditions.

With the **ENABLE-A** and **ENABLE-B** commands open, access the AUTOTUNE MENU and set **I073** [1: Motor Tune] and **I074** = [2: FOC Auto + rot]. Use the **ESC** key to accept changes.

Close the **ENABLE-A** and **ENABLE-B** commands and wait until autotune is over (warning "W32 Open Enable" is displayed). When autotune is complete, the value obtained for the mutual inductance (**C024**) and the rotor time constant (**C025**) are automatically saved.

**8) Startup:** Now that all the parameters have been set for the FOC motor control algorithm, activate the **ENABLE-A** input (terminal 15), the **ENABLE-B** input and the **START** input (terminal 14) and send a speed reference: the **RUN** LED and **REF** LED will come on and the motor will start rotating. Make sure that the motor is rotating in the correct direction. If not, set parameter **C014** (Phase Rotation) = [1:Yes], or open the **ENABLE-A**, **ENABLE-B** and **START** inputs, remove voltage from the drive and, after waiting at least 20 minutes, swap two of the motor phases.

**9) Speed regulator adjustment:** If overshoot occurs when the speed setpoint is attained or if a system instability is detected (uneven motor operation), adjust the parameters relating to the speed loop (SPEED LOOP AND CURRENT BALANCING MENU). Set the two parameters relating to integral time (**P125**, **P126**) as [Disabled] and set low values for the parameters relating to proportional gain (**P128**, **P129**). Set equal values for **P127** and **P128** and increase them until overshoot takes place when the setpoint is attained. Decrease **P128** and **P129** by approx. 30%, then decrease the high values set for integral time in **P125** and **P126** (keep both values equal) until an acceptable setpoint response is obtained. Check to see if the motor runs smoothly at constant speed.

**10) Possible failures:** If alarm “**A060** Fault No Curr.” trips, this means that the current loop is not properly tuned. Follow the instructions given in step 6 and decrease the value of  $I_0$  (parameter **C021** in the MOTOR CONFIGURATION MENU).

If the motor is noisy when starting, this means that the rotor time constant is not correct. Follow the instructions given in step 7 again, or manually change the value of the rotor time constant (parameter **C025**) for a smooth motor startup.

If no failure occurred, go to step 11. Otherwise, check the drive connections paying particular attention to supply voltages, DC link and input reference. Also check if alarm messages are displayed. In the Motor Measures Menu, check the speed reference (**M000**), the reference speed processed by the ramps (**M002**), the supply voltage of the control section (**M030**), the DC link voltage (**M029**), the condition of the control terminals (**M033**). Check to see if these readouts match with the measured values.

**11) Additional parameter modifications:**

For the optimization of the motor performance, adjust parameters **C021** (no-load current), **C024** (mutual inductance), **C025** (rotor time constant). Consider the following:

- **C021 Too high values** → Lower torque, especially at rated speed, because most part of the voltage imposed by the drive is used to magnetize the motor instead of generating a proper motor torque;
- **C021 Too low values** → Because of the motor flux weakening, higher current ratings are needed;
- **C024 Mutual inductance** → This is computed each time the no-load current level is changed. This is not binding for the motor control, but strongly affects the correct estimation of the output torque; in case of overestimation, decrease **C024**, and vice versa;
- **C025 Optimum value** → To obtain the optimum value of the rotor time constant, the best way consists in performing several attempts with a constant load but with different values of **C025**. The optimum value is the one ensuring to obtain the output torque with the lower current (see **M026**).

When parameter **P003** = Standby Only (condition required for changing C parameters), you can change **Cxxx** parameters in the CONFIGURATION menu only when the drive is DISABLED or STOPPED, whereas if **P003** = Standby + Fluxing, you can change **Cxxx** parameters when the motor is stopped but the drive is enabled.

You can write down any custom parameters in the table provided on the last pages of this Programming Guide (CUSTOM PARAMETERS).

**12) Reset:**

If an alarm trips, find the cause responsible for the alarm and reset the drive. Enable input MDI3 (terminal 16) for some time, or press the **RESET** key on the display/keypad.



**NOTE**

The **ENABLE-A** and **ENABLE-B** inputs are allocated to the STO function. If this safety functionality is to be adopted, the control mode and the control circuit of these signals must be accomplished as per the Safe Torque Off Function - Application Manual.

That manual also includes a detailed validation procedure of the control configuration of the STO function to be executed upon first start-up and also periodically at yearly intervals.

## 8. MEASURES MENU

### 8.1. Overview

---

The Measures Menu contains the variables measured by the drive that can be used by the user. In the display/keypad, measures are divided into subgroups. The measure subgroups are the following:

#### **Motor Measures Menu**

This menu contains: the values of the speed reference at constant rpm, the values of the reference being used and the speed values of the connected motor expressed in rpm; the drive rated frequency; the torque reference at constant rpm, the torque demand and the motor torque output, the torque limit reference at constant speed and the torque limit being used expressed both in Nm and as a percentage of the rated torque of the selected motor; the flux reference and the electrical variables measured by the drive mains side, the DC-bus and output; the measures of the incremental or absolute encoders being used.

#### **PID Controller Menu**

This menu contains the values relating to the PID controller of the Penta drive.

#### **Digital Inputs Menu**

This menu contains the state of the drive digital inputs and the indication of the functions programmed for the digital inputs of the Penta drive.

#### **References Menu**

This menu contains the following values: analog references, the encoder input and the frequency input references, the speed/torque or reference/feedback values of the PID coming from serial link or fieldbus.

#### **Outputs Menu**

This menu contains the state of the drive digital outputs, analog outputs and frequency outputs.

#### **Temperatures from PT100 Menu**

This menu contains the temperature values detected in the first four analog channels of ES847 I/O expansion board (this menu is available only if ES847 is fitted).

#### **Autodiagnosics Menu**

This menu contains the temperature values, the operation time counter and the supply time counter, the active alarm and the drive status.

#### **Data Logger Measures Menu**

This menu contains the status of the type of connections (serial links, Ethernet and modem) supported by ES851 Data Logger board (this menu is available only if the Data Logger ES851 is fitted).

#### **Digital Input Settings Menu**

This menu contains the functions assigned to the digital inputs.

#### **Fault List Menu**

This menu contains the trip log of the last eight alarms tripped and the values of some measures being used when the alarm trip was stored.

#### **PowerOff Log Menu**

This menu contains the value of some measures being used at the drive power off.

## 8.2. Motor Measures Menu

This menu contains speed values, torque values and electrical variables measured by the drive on the mains side, DC bus and output.

### M000 Speed Reference at Constant RPM

|               |                 |  |  |
|---------------|-----------------|--|--|
| <b>M000-1</b> | <b>Range</b>    | ± 32000<br>(integer part)<br>± 99 (decimal<br>part)  | ± 32000.99 rpm<br><b>Note:</b> The actual range depends on the selected motor, because it is defined by the value set in the parameters for the motor max. speed and min. speed.<br><b>C028–C029</b> Motor 1<br><b>C071–C072</b> Motor 2<br><b>C114–C115</b> Motor 3 |
|               | <b>Active</b>   | Active only when a speed reference is used for the selected motor.   |  |
|               | <b>Address</b>  | 1650 (integer part) 1651 (decimal part)  |  |
|               | <b>Function</b> | Value of the speed reference obtained when the motor rotates at constant speed, once the preset ramp time is over. |  |

### M002 Speed Ramp Output

|               |                 |   |  |
|---------------|-----------------|---|--|
| <b>M002-3</b> | <b>Range</b>    | ± 32000<br>(integer part)<br>± 99 (decimal<br>part)                             | ± 32000.99 rpm<br><b>Note:</b> The actual range depends on the selected motor, because it is defined by the value set in the parameters for the motor max. speed and min. speed.<br><b>C028–C029</b> Motor 1<br><b>C071–C072</b> Motor 2<br><b>C114–C115</b> Motor 3 |
|               | <b>Active</b>   | Active only when a speed reference is used for the selected motor.              |  |
|               | <b>Address</b>  | 1652 (integer part) 1653 (decimal part)   |  |
|               | <b>Function</b> | This is the measure of the speed value processed with respect to the ramp time. |  |

### M004 Motor Speed

|               |                 |   |                |
|---------------|-----------------|---|----------------|
| <b>M004-5</b> | <b>Range</b>    | ± 32000<br>(integer part)<br>± 99 (decimal<br>part) | ± 32000.99 rpm |
|               | <b>Active</b>   | Always active.                                      |                |
|               | <b>Address</b>  | 1654 (integer part) 1655 (decimal part)             |                |
|               | <b>Function</b> | Motor speed value.                                  |                |

### M006 Drive Output Frequency

|             |                 |   |                            |
|-------------|-----------------|---|----------------------------|
| <b>M006</b> | <b>Range</b>    | ± 10000   | ± 1000.0 Hz (see Table 69) |
|             | <b>Active</b>   | Always active.  |                            |
|             | <b>Address</b>  | 1656  |                            |
|             | <b>Function</b> | This is the measure of the voltage frequency output of the drive. |                            |

**M007 Torque Reference at Constant Speed (Nm)**

|             |                 |   |   |
|-------------|-----------------|---|---|
| <b>M007</b> | <b>Range</b>    | ± 3200  | ± 3200 Nm<br><u>Note:</u> The actual range depends on the torque limit values set for the selected motor.<br><b>C047–C048</b> Motor 1<br><b>C090–C091</b> Motor 2<br><b>C133–C134</b> Motor 3 |
|             | <b>Active</b>   | Active only when a torque reference is used for the selected motor.                         |   |
|             | <b>Address</b>  | 1657  |   |
|             | <b>Function</b> | This is the measure of the torque reference required at constant speed and expressed in Nm. |   |

**M008 Torque Demand (Nm)**

|             |                 |  |   |
|-------------|-----------------|--|---|
| <b>M008</b> | <b>Range</b>    | ± 32000  | ± 32000 Nm<br><u>Note:</u> The actual range depends on the rated torque and the torque limit values set for the selected motor.<br><b>C047–C048</b> Motor 1<br><b>C090–C091</b> Motor 2<br><b>C133–C134</b> Motor 3 |
|             | <b>Active</b>   | Active for VTC and FOC controls only.  |   |
|             | <b>Address</b>  | 1658   |   |
|             | <b>Function</b> | <u>With speed control:</u> Torque demand of the speed regulator for the type of control used.<br><u>With torque control:</u> Torque reference processed in respect to the preset torque ramp time. |   |

**M009 Torque Generated by the Motor (Nm)**

|             |                 |  |            |
|-------------|-----------------|--|------------|
| <b>M009</b> | <b>Range</b>    | ± 32000  | ± 32000 Nm |
|             | <b>Active</b>   | Active for VTC and FOC controls only.                            |            |
|             | <b>Address</b>  | 1659   |            |
|             | <b>Function</b> | Approximate value of the torque produced by the connected motor. |            |

**M010 Torque Reference at Constant RPM (%)**

|             |                 |   |   |
|-------------|-----------------|---|---|
| <b>M010</b> | <b>Range</b>    | ± 500   | ± 500 %<br><u>Note:</u> The actual range depends on the torque limit values set for the selected motor.<br><b>C047–C048</b> Motor 1<br><b>C090–C091</b> Motor 2<br><b>C133–C134</b> Motor 3 |
|             | <b>Active</b>   | Active only when a torque reference is used for the selected motor.   |   |
|             | <b>Address</b>  | 1660  |   |
|             | <b>Function</b> | This is the measure of the torque reference required at constant speed and expressed as a percentage of the motor rated torque. |   |

**M011 Torque Demand (%)**

|             |                 |  |   |
|-------------|-----------------|--|---|
| <b>M011</b> | <b>Range</b>    | ± 500  | ± 500 %<br><u>Note:</u> The actual range depends on the torque limit values set for the selected motor.<br><b>C047–C048</b> Motor 1<br><b>C090–C091</b> Motor 2<br><b>C133–C134</b> Motor 3 |
|             | <b>Active</b>   | Active for VTC and FOC controls only.  |   |
|             | <b>Address</b>  | 1661   |   |
|             | <b>Function</b> | <u>With speed control:</u> Torque demand of the speed regulator expressed as a percentage of the motor rated torque.<br><u>With torque control:</u> Torque reference processed with respect to the preset torque ramp time and expressed as a reference of the motor rated torque. |   |

**M012 Torque Generated by the Motor (%)**

|                 |  |                                       |         |
|-----------------|--|---------------------------------------|---------|
| <b>M012</b>     | <b>Range</b>   | ± 500                                 | ± 500 % |
|                 | <b>Active</b>  | Active only for VTC and FOC controls. |         |
|                 | <b>Address</b>   | 1662                                  |         |
| <b>Function</b> | Approximate value of the torque produced by the motor and expressed as a percentage of the rated torque of the selected motor. |                                       |         |

**M013 Torque Limit Demand before Ramps (Nm)**

|             |                 |  |   |
|-------------|-----------------|--|---|
| <b>M013</b> | <b>Range</b>    | ± 32000  | ± 32000 Nm<br><u>Note:</u> The actual range depends on the preset torque limit values and the rated torque of the selected motor.<br><b>C047–C048</b> Motor 1<br><b>C090–C091</b> Motor 2<br><b>C133–C134</b> Motor 3 |
|             | <b>Active</b>   | Active for VTC and FOC controls only.  |   |
|             | <b>Address</b>  | 1663   |   |
|             | <b>Function</b> | This is the limit value for the torque at constant speed. If an external torque limit is used, the value of this measure is the torque limit obtained at constant speed; on the other hand, if the torque limit is internal to the drive, this value is the actual torque limit expressed in Nm. |   |

**M014 Torque Limit Demand after Ramps (Nm)**

|             |                 |   |   |
|-------------|-----------------|---|---|
| <b>M014</b> | <b>Range</b>    | ± 32000   | ± 32000 Nm<br><u>Note:</u> The actual range depends on the preset torque limit values and the rated torque of the selected motor.<br><b>C047–C048</b> Motor 1<br><b>C090–C091</b> Motor 2<br><b>C133–C134</b> Motor 3 |
|             | <b>Active</b>   | Active for VTC and FOC controls only.                       |   |
|             | <b>Address</b>  | 1664  |   |
|             | <b>Function</b> | This is the torque limit value being used, expressed in Nm. |   |

**M013a Speed Limit before the Ramps**

|              |                 |   |             |
|--------------|-----------------|---|-------------|
| <b>M013a</b> | <b>Range</b>    | ± 32000   | ± 32000 rpm |
|              | <b>Active</b>   | Active for FOC only.  |             |
|              | <b>Address</b>  | 1726  |             |
|              | <b>Function</b> | Limit value at constant speed of the motor speed of rotation in “torque control with speed limit” mode (C011=2 for Motor 1; C054, C097 for Motors 2 and 3). |             |

**M014a Speed Limits after the Ramps**

|              |                 |   |            |
|--------------|-----------------|---|------------|
| <b>M014a</b> | <b>Range</b>    | ± 32000   | ± 2000 rpm |
|              | <b>Active</b>   | Active for FOC only.  |            |
|              | <b>Address</b>  | 1727  |            |
|              | <b>Function</b> | Current limit value of the motor speed of rotation in “torque control with speed limit” mode (C011=2 for Motor 1; C054, C097 for Motors 2 and 3). |            |

**M015 Torque Limit Reference before Ramps (%)**

|             |                 |  |   |
|-------------|-----------------|--|---|
| <b>M015</b> | <b>Range</b>    | ± 500  | ± 500 %<br><u>Note:</u> The actual range depends on the torque limit values set for the selected motor.<br><b>C047–C048</b> Motor 1<br><b>C090–C091</b> Motor 2<br><b>C133–C134</b> Motor 3 |
|             | <b>Active</b>   | Active for VTC and FOC controls only.  |   |
|             | <b>Address</b>  | 1665   |   |
|             | <b>Function</b> | This is the limit value for the torque at constant speed expressed as a percentage of the rated torque of the selected motor. If an external torque limit is used, the value of this measure is the torque limit obtained at constant speed; on the other hand, if the torque limit is internal to the drive, this value is the actual torque limit. |   |

**M016 Torque Limit Reference after Ramps (%)**

|             |                 |  |   |
|-------------|-----------------|--|---|
| <b>M016</b> | <b>Range</b>    | ± 500  | ± 500 %<br><u>Note:</u> The actual range depends on the torque limit values set for the selected motor.<br><b>C047–C048</b> Motor 1<br><b>C090–C091</b> Motor 2<br><b>C133–C134</b> Motor 3 |
|             | <b>Active</b>   | Active for VTC and FOC controls only.  |   |
|             | <b>Address</b>  | 1666   |   |
|             | <b>Function</b> | This is the torque limit value being used expressed as a percentage of the motor rated torque. |   |

**M017 Flux Reference**

|             |                 |  |             |
|-------------|-----------------|--|-------------|
| <b>M017</b> | <b>Range</b>    | 0 ÷ 500  | 0 ÷ 5.00 Wb |
|             | <b>Active</b>   | Active for VTC and FOC controls only.                |             |
|             | <b>Address</b>  | 1667   |             |
|             | <b>Function</b> | Flux reference required and expressed in Weber (Wb). |             |

**M026 Output Current**

|             |                 |   |  |
|-------------|-----------------|---|--|
| <b>M026</b> | <b>Range</b>    | 0 ÷ 65535                                     | 0 ÷ 6553.5 A<br><i>Note:</i> The actual range depends on the drive size. |
|             | <b>Active</b>   | Always active.                                |  |
|             | <b>Address</b>  | 1676  |  |
|             | <b>Function</b> | Measurement of the RMS of the output current. |  |

**M026a Motor Thermal Capacity**

|              |                 |   |              |
|--------------|-----------------|---|--------------|
| <b>M026a</b> | <b>Range</b>    | 0 ÷ 1000  | 0.0 ÷ 100.0% |
|              | <b>Active</b>   | Always active.  |              |
|              | <b>Address</b>  | 1728  |              |
|              | <b>Function</b> | Heating of the connected motor.<br>This parameter indicates the current level of the motor heating following I2t pattern set in the MOTOR THERMAL PROTECTION MENU. This value is expressed as a percentage of the allowable asymptotic value. |              |

**M027 Output Voltage**

|             |                 |   |  |
|-------------|-----------------|---|--|
| <b>M027</b> | <b>Range</b>    | 0 ÷ 65535                                 | 0 ÷ 65535 V<br><i>Note:</i> The actual range depends on the drive voltage class. |
|             | <b>Active</b>   | Always active.                            |  |
|             | <b>Address</b>  | 1677                                      |  |
|             | <b>Function</b> | Measure of the RMS of the output voltage. |  |

**M028 Output Power**

|             |                 |  |  |
|-------------|-----------------|--|--|
| <b>M028</b> | <b>Range</b>    | -32768 ÷ +32767  | -3276.8 ÷ +3276.7 kW<br><i>Note:</i> The actual range depends on the drive size. |
|             | <b>Active</b>   | Always active.   |  |
|             | <b>Address</b>  | 1678   |  |
|             | <b>Function</b> | Measure of the active power produced by the drive.<br>A negative value indicates input power (the motor is regenerating energy). |  |

**M028a Energy Consumption**

|              |                 |   |                     |
|--------------|-----------------|---|---------------------|
| <b>M028a</b> | <b>Range</b>    | 0 ÷ 1000000000  | 0 ÷ 10000000.00 kWh |
|              | <b>Active</b>   | Always active.  |                     |
|              | <b>Address</b>  | 1723-1724 (LSWord, MSWord)  |                     |
|              | <b>Function</b> | Counter of the drive energy consumption.<br>This is a value expressed in 32 bits divided into two 16-bit words: the low part and the high part. |                     |

**M029 DC-Bus Voltage**

|             |                 |  |            |
|-------------|-----------------|--|------------|
| <b>M029</b> | <b>Range</b>    | 0 ÷ 1400                                     | 0 ÷ 1400 V |
|             | <b>Active</b>   | Always active.                               |            |
|             | <b>Address</b>  | 1679   |            |
|             | <b>Function</b> | Measure of the voltage in the drive DC-link. |            |

**M030 Supply Voltage**

|             |                 |   |            |
|-------------|-----------------|---|------------|
| <b>M030</b> | <b>Range</b>    | 0 ÷ 1000  | 0 ÷ 1000 V |
|             | <b>Active</b>   | Always active.  |            |
|             | <b>Address</b>  | 1680  |            |
|             | <b>Function</b> | Measure of the RMS value of the drive supply voltage. |            |

### 8.3. PID Regulator Menu

This menu contains the measures relating to the input and output values of the internal PID regulator.

#### M018 PID Reference at Constant RPM (%)

|             |                 |  |   |
|-------------|-----------------|--|---|
| <b>M018</b> | <b>Range</b>    | ±10000   | ±100.00 %<br><b>Note:</b> The actual range depends on the max. value and the min. value of the PID reference set in parameters <b>P245–P246</b> . |
|             | <b>Active</b>   | Always active.   |   |
|             | <b>Address</b>  | 1668   |   |
|             | <b>Function</b> | This is the measure of the PID reference expressed as a percentage. Scaling is detailed in the PID PARAMETERS MENU and the PID CONFIGURATION MENU. |   |

#### M018a PID2 Reference at Constant RPM (%)

|              |                 |   |  |
|--------------|-----------------|---|--|
| <b>M018a</b> | <b>Range</b>    | ±10000  | ±100.00 %<br><b>Note:</b> The actual range depends on the max. value and the min. value of the PID2 reference set in parameters <b>P445-P446</b> . |
|              | <b>Active</b>   | This measure is active if enabled from <b>C291a</b>   |  |
|              | <b>Address</b>  | 1731  |  |
|              | <b>Function</b> | This is the measure percent of the reference selected with <b>C286</b> for the PID2 or the 2-zone mode. Scaling is detailed in the PID2 PARAMETERS MENU and the PID CONFIGURATION MENU. |  |

#### M019 PID Reference after Ramps (%)

|             |                 |  |   |
|-------------|-----------------|--|---|
| <b>M019</b> | <b>Range</b>    | ±10000   | ±100.00 %<br><b>Note:</b> The actual range depends on the max. value and the min. value of the PID reference set in parameters <b>P245–P246</b> . |
|             | <b>Active</b>   | Always active.   |   |
|             | <b>Address</b>  | 1669   |   |
|             | <b>Function</b> | This is the measure of the PID reference after the ramps expressed as a percentage. Scaling is detailed in the PID PARAMETERS MENU and the PID CONFIGURATION MENU. |   |

#### M019a PID2 Reference after Ramps (%)

|              |                 |   |  |
|--------------|-----------------|---|--|
| <b>M019a</b> | <b>Range</b>    | ±10000  | ±100.00 %<br><b>Note:</b> The actual range depends on the max. value and the min. value of the PID2 reference set in parameters <b>P445-P446</b> . |
|              | <b>Active</b>   | This measure is active if enabled from <b>C291a</b>   |  |
|              | <b>Address</b>  | 1732  |  |
|              | <b>Function</b> | This is the measure percent of the current PID reference after the ramps selected with <b>C286</b> for the PID2 or the 2-zone mode. Scaling is detailed in the PID2 PARAMETERS MENU and the PID CONFIGURATION MENU. |  |

**M020 PID Feedback (%)**

|             |                 |  |  |
|-------------|-----------------|--|--|
| <b>M020</b> | <b>Range</b>    | ±10000   | ±100.00 %<br><b>Note:</b> The actual range depends on the max. value and the min. value of the PID feedback set in parameters <b>P247–P248</b> . |
|             | <b>Active</b>   | Always active.   |  |
|             | <b>Address</b>  | 1670   |  |
|             | <b>Function</b> | This is the measure of the PID feedback expressed as a percentage. Scaling is detailed in the PID PARAMETERS MENU and the PID CONFIGURATION MENU.. |  |

**M020a PID2 Feedback (%)**

|              |                 |   |   |
|--------------|-----------------|---|---|
| <b>M020a</b> | <b>Range</b>    | ±10000  | ±100.00 %<br><b>Note:</b> The actual range depends on the max. value and the min. value of the PID2 feedback set in parameters <b>P447-P448</b> . |
|              | <b>Active</b>   | This measure is active if enabled from <b>C291a</b>   |   |
|              | <b>Address</b>  | 1733  |   |
|              | <b>Function</b> | This is the measure percent of the PID2 feedback selected with <b>C286</b> for the PID2 or the 2-zone mode. Scaling is detailed in the PID2 PARAMETERS MENU and the PID CONFIGURATION MENU. |   |

**M021 PID Error (%)**

|             |                 |  |  |
|-------------|-----------------|--|--|
| <b>M021</b> | <b>Range</b>    | ±10000   | ±100.00 %<br><b>Note:</b> The actual range depends on the min. and max. saturation values of the reference and the feedback set in parameters <b>P245–P246</b> for the reference and in <b>P247–P248</b> for the feedback. |
|             | <b>Active</b>   | Always active.   |  |
|             | <b>Address</b>  | 1671   |  |
|             | <b>Function</b> | This is the measure of the PID input error expressed as a percentage. See also the PID PARAMETERS MENU and the PID CONFIGURATION MENU. |  |

**M021a PID2 Error (%)**

|              |                 |   |  |
|--------------|-----------------|---|--|
| <b>M021a</b> | <b>Range</b>    | ±10000  | ±100.00 %<br><b>Note:</b> The actual range depends on the min. and max. saturation values of the reference and the feedback set in parameters <b>P445-P446</b> for the reference and in <b>P447–P448</b> for the feedback. |
|              | <b>Active</b>   | This measure is active if enabled from <b>C291a</b>   |  |
|              | <b>Address</b>  | 1736  |  |
|              | <b>Function</b> | This is the measure percent of the PID2 input error or the 2-zone mode input error (difference between the reference selected with <b>C286</b> and the feedback selected with <b>C289</b> ). Please refer to the PID2 PARAMETERS MENU and the PID CONFIGURATION MENU. |  |

**M022 PID Output (%)**

|             |                 |  |  |
|-------------|-----------------|--|--|
| <b>M022</b> | <b>Range</b>    | ±10000   | ±100.00 %<br><b>Note:</b> The actual range depends on the min. and max. saturation values of the PID output set in parameters <b>P236–P237</b> . |
|             | <b>Active</b>   | Always active.   |  |
|             | <b>Address</b>  | 1672   |  |
|             | <b>Function</b> | This is the measure of the output produced by the PID regulator and expressed as a percentage. Please refer to the PID PARAMETERS MENU and the PID CONFIGURATION MENU for the scaling of the PID output. |  |

**M022a PID2 Output (%)**

|              |                 |   |  |
|--------------|-----------------|---|--|
| <b>M022a</b> | <b>Range</b>    | ±10000  | ±100.00 %<br><b>Note:</b> The actual range depends on the min. and max. saturation values of the PID output set in parameters <b>P436–P437</b> . |
|              | <b>Active</b>   | This measure is active if enabled from <b>C291a</b>   |  |
|              | <b>Address</b>  | 1718  |  |
|              | <b>Function</b> | This is the measure of the output produced by the PID2 regulator and expressed as a percentage. Scaling is detailed in the PID2 PARAMETERS MENU and the PID CONFIGURATION MENU. |  |

**M023 PID Reference after Ramps**

|             |                 |  |   |
|-------------|-----------------|--|---|
| <b>M023</b> | <b>Range</b>    | ±32000   | <b>Note:</b> The actual range depends on the max. value and the min. value of the PID reference set in parameters <b>P245–P246</b> and on the gain level set in <b>P257</b> . |
|             | <b>Active</b>   | Always active.   |   |
|             | <b>Address</b>  | 1673   |   |
|             | <b>Function</b> | This is the measure of the reference after the ramps being used for the PID regulator, as <b>M019</b> but multiplied by the gain level set in <b>P257</b> (see also the PID PARAMETERS MENU and the PID CONFIGURATION MENU). As for the display/keypad, the unit of measure can be programmed with parameters <b>P267, P267a</b> in the DISPLAY/KEYPAD menu. |   |

**M023a PID2 Reference after Ramps**

|              |                 |   |   |
|--------------|-----------------|---|---|
| <b>M023a</b> | <b>Range</b>    | ±32000  | <b>Note:</b> The actual range depends on the min. and max. values of the PID2 reference set in parameters <b>P445–P446</b> and on the gain level set in <b>P457</b> . |
|              | <b>Active</b>   | This measure is active if enabled from <b>C291a</b>   |   |
|              | <b>Address</b>  | 1737  |   |
|              | <b>Function</b> | This is the measure of the reference being used for the PID2 or the 2-zone mode, as <b>M019a</b> but multiplied by the gain level set in <b>P457</b> (see also the PID2 PARAMETERS MENU and the PID CONFIGURATION MENU). As for the display/keypad, the unit of measure can be programmed with parameters <b>P267b, P267c</b> in the DISPLAY/KEYPAD menu. |   |

**M024 PID Feedback**

|  |             |                 |   |  |
|--|-------------|-----------------|---|--|
|  | <b>M024</b> | <b>Range</b>    | ±32000  | <b>Note:</b> The actual range depends on the max. value and the min. value of the PID feedback set in parameters <b>P247–P248</b> and on the gain level set in <b>P257</b> . |
|  |             | <b>Active</b>   | Always active.  |  |
|  |             | <b>Address</b>  | 1674  |  |
|  |             | <b>Function</b> | This is the measure of the feedback being used for the PID regulator, as <b>M020</b> but multiplied by the gain level set in <b>P257</b> (see also the PID PARAMETERS MENU and the PID CONFIGURATION MENU). As for the display/keypad, the unit of measure can be programmed with parameters <b>P267</b> , <b>P267a</b> in the DISPLAY/KEYPAD menu. |  |

**M024a PID2 Feedback**

|  |              |                 |   |   |
|--|--------------|-----------------|---|---|
|  | <b>M024a</b> | <b>Range</b>    | ±32000  | <b>Note:</b> The actual range depends on the max. value and the min. value of the PID2 feedback set in parameters <b>P447–P448</b> and on the gain level set in <b>P457</b> . |
|  |              | <b>Active</b>   | This measure is active if enabled from <b>C291a</b>   |   |
|  |              | <b>Address</b>  | 1738  |   |
|  |              | <b>Function</b> | This is the measure of the feedback being used for the PID2 regulator or the 2-zone mode as <b>M020a</b> but multiplied by the gain level set in <b>P457</b> (see also the PID2 PARAMETERS MENU and the PID CONFIGURATION MENU). As for the display/keypad, the unit of measure can be programmed with parameters <b>P267b</b> , <b>P267c</b> in the DISPLAY/KEYPAD menu. |   |

## 8.4. Digital Inputs Menu

This menu allows checking the state of the command sources for the digital inputs (local terminals, serial link and fieldbus), the terminal board resulting from their combination and the terminals which are actually used for the drive control. The terminals which are actually used to control the drive also consider any timers applied to the digital inputs.

### M031 Delayed Digital Inputs

|             |                 |  |             |
|-------------|-----------------|--|-------------|
| <b>M031</b> | <b>Range</b>    | Bit-controlled measure   | See Table 1 |
|             | <b>Active</b>   | Always active.   |             |
|             | <b>Address</b>  | 1681   |             |
|             | <b>Function</b> | Status of the control terminal board used by the drive.<br>This is the terminal board resulting from the combination of the preset command sources (local terminal board, serial link and fieldbus), where:<br>- Inputs <b>MDI1</b> to <b>MDI8</b> are the result of the OR between the different control sources.<br>- The <b>ENABLE (E)</b> status is the result of the AND of inputs <b>MDI2&amp;S</b> of the physical terminals and of <b>MDI2</b> inputs of all the other programmed control sources.<br>- The <b>ENABLE SW (ESW)</b> is the result of the AND of the inputs programmed as <b>ENABLE SW (C152)</b> of all the programmed command sources.<br>See also the CONTROL METHOD MENU and the TIMERS MENU.<br>Refer to Figure 49 for the <b>ENABLE</b> and <b>ENABLE SW</b> status. |             |

### M032 Instant Digital Inputs

|             |                 |  |             |
|-------------|-----------------|--|-------------|
| <b>M032</b> | <b>Range</b>    | Bit-controlled measure   | See Table 1 |
|             | <b>Active</b>   | Always active.   |             |
|             | <b>Address</b>  | 1682   |             |
|             | <b>Function</b> | Status of the virtual control terminal board before applying the timers to the digital inputs (if no timer is applied, it matches with <b>M031</b> ).<br>See the CONTROL METHOD MENU and the TIMERS MENU.<br>Refer to Figure 49 for the <b>ENABLE</b> and <b>ENABLE SW</b> status. |             |

Table 1: Coding of Measures M031, M032

| Bit n. | Digital Input | Bit n. | Digital Input  |
|--------|---------------|--------|----------------|
| 0      | MDI1          | 5      | MDI6/ECHA/FINA |
| 1      | MDI2(ENABLE)  | 6      | MDI7/ECHB      |
| 2      | MDI3(RESET)   | 7      | MDI8/FINB      |
| 3      | MDI4          | 8      | ENABLE-SW      |
| 4      | MDI5          | 9      | ENABLE         |

### M033 Local Control Terminal Board

|             |                 |  |             |
|-------------|-----------------|--|-------------|
| <b>M033</b> | <b>Range</b>    | Bit-controlled measure   | See Table 3 |
|             | <b>Active</b>   | Always active.   |             |
|             | <b>Address</b>  | 1683   |             |
|             | <b>Function</b> | Status of the digital inputs in the drive physical terminal board.<br>The status of <b>MDI2&amp;S (S)</b> input is the result of a logic AND between <b>ENABLE-A</b> and <b>ENABLE-B</b> physical signals. |             |

Table 2: Coding of Measures M033

| Bit n. | Digital Input | Bit n. | Digital Input  |
|--------|---------------|--------|----------------|
| 0      | MDI1(START)   | 4      | MDI5           |
| 1      | MDI2&S (S)    | 5      | MDI6/ECHA/FINA |
| 2      | MDI3(RESET)   | 6      | MDI7/ECHB      |
| 3      | MDI4          | 7      | MDI8/FINB      |

**M034 Control Terminals from Serial Link**

|             |                 |  |             |
|-------------|-----------------|--|-------------|
| <b>M034</b> | <b>Range</b>    | Bit-controlled measure   | See Table 3 |
|             | <b>Active</b>   | Always active.   |             |
|             | <b>Address</b>  | 1684   |             |
|             | <b>Function</b> | Status of the digital inputs in the terminal board controlled via serial link. |             |

**M035 Control Terminal Board from Fieldbus**

|             |                 |  |             |
|-------------|-----------------|--|-------------|
| <b>M035</b> | <b>Range</b>    | Bit-controlled measure   | See Table 3 |
|             | <b>Active</b>   | Always active.   |             |
|             | <b>Address</b>  | 1685   |             |
|             | <b>Function</b> | State of the digital inputs in the terminal board controlled via fieldbus. |             |

**Table 3: Coding of Measures M034, M035**

| Bit n. | Digital Input | Bit n. | Digital Input  |
|--------|---------------|--------|----------------|
| 0      | MDI1          | 4      | MDI5           |
| 1      | MDI2          | 5      | MDI6/ECHA/FINA |
| 2      | MDI3(RESET)   | 6      | MDI7/ECHB      |
| 3      | MDI4          | 7      | MDI8/FINB      |

**M036 Auxiliary Digital Inputs in the Terminal Board**

|             |                 |  |             |
|-------------|-----------------|--|-------------|
| <b>M036</b> | <b>Range</b>    | Bit-controlled measure   | See Table 4 |
|             | <b>Active</b>   | Always active.   |             |
|             | <b>Address</b>  | 1686   |             |
|             | <b>Function</b> | Status of the auxiliary digital inputs in ES847 or ES870 terminal board. |             |

**M036a Auxiliary Digital Inputs via Serial Link**

|              |                 |   |             |
|--------------|-----------------|---|-------------|
| <b>M036a</b> | <b>Range</b>    | Bit-controlled measure                                  | See Table 4 |
|              | <b>Active</b>   | Always active.  |             |
|              | <b>Address</b>  | 1713  |             |
|              | <b>Function</b> | Status of the auxiliary digital inputs via serial link. |             |

**M036b Auxiliary Digital Inputs via PROFIdrive**

|              |                 |  |             |
|--------------|-----------------|--|-------------|
| <b>M036b</b> | <b>Range</b>    | Bit-controlled measure                                 | See Table 4 |
|              | <b>Active</b>   | Always active.   |             |
|              | <b>Address</b>  | 1717   |             |
|              | <b>Function</b> | Status of the auxiliary digital inputs via PROFIdrive. |             |

**Table 4: Coding of Measures M036, M036a, M036b**

| Bit n. | Digital Input | Bit n. | Digital Input |
|--------|---------------|--------|---------------|
| 0      | XMDI1         | 4      | XMDI5         |
| 1      | XMDI2         | 5      | XMDI6         |
| 2      | XMDI3         | 6      | XMDI7         |
| 3      | XMDI4         | 7      | XMDI8         |

## 8.5. References Menu

This menu contains the measures of the possible reference sources for speed, torque or PID available in the terminal board (analog inputs, frequency inputs and encoder input) and sent via serial link or fieldbus.

### M037 REF External Analog Reference

|             |                 |  |   |
|-------------|-----------------|--|---|
| <b>M037</b> | <b>Range</b>    | Function of the preset type of reference (voltage/current).                      | Function of the type of reference (voltage/current) set in <b>P050</b> . The numerical value always includes two decimal figures; the unit of measure is V or mA. |
|             | <b>Active</b>   | Always active.   |   |
|             | <b>Address</b>  | 1687   |   |
|             | <b>Function</b> | Measure of the voltage /current value detected by the drive in REF analog input. |   |

### M038 AIN1 External Analog Reference

|             |                 |   |   |
|-------------|-----------------|---|---|
| <b>M038</b> | <b>Range</b>    | Function of the preset type of reference (voltage/current)                        | Function of the type of reference (voltage/current) set in <b>P055</b> . The numerical value always includes two decimal figures; the unit of measure is V or mA. |
|             | <b>Active</b>   | Always active.  |   |
|             | <b>Address</b>  | 1688  |   |
|             | <b>Function</b> | Measure of the voltage /current value detected by the drive in AIN1 analog input. |   |

### M039 AIN2 External Analog Reference

|             |                 |   |  |
|-------------|-----------------|---|--|
| <b>M039</b> | <b>Range</b>    | Function of the preset type of reference (voltage/current).                       | Function of the type of reference (voltage/current) set in <b>P060</b> . The numerical value always includes two decimals; the unit of measure is V or mA. |
|             | <b>Active</b>   | Always active.  |  |
|             | <b>Address</b>  | 1689  |  |
|             | <b>Function</b> | Measure of the voltage /current value detected by the drive in AIN2 analog input. |  |

### M039a XAIN4 External Analog Reference

|              |                 |   |  |
|--------------|-----------------|---|--|
| <b>M039a</b> | <b>Range</b>    | Function of the preset type of reference.                                 | Function of the type of reference (voltage) set in <b>P390</b> . The numerical value always includes two decimals; the unit of measure is V. |
|              | <b>Active</b>   | Active only if set via parameter <b>R023</b> .                            |  |
|              | <b>Address</b>  | 1729  |  |
|              | <b>Function</b> | Measure of the voltage value detected by the drive in XAIN4 analog input. |  |

**M039b XAIN5 External Analog Reference**

|              |                 |   |   |
|--------------|-----------------|---|---|
| <b>M039b</b> | <b>Range</b>    | Function of the preset type of reference.                                     | Function of the type of reference (current) set in <b>P395</b> . The numerical value always includes two decimals; the unit of measure is mA. |
|              | <b>Active</b>   | Active only if set via parameter <b>R023</b> .                                |   |
|              | <b>Address</b>  | 1730  |   |
|              | <b>Function</b> | Measure of the current value detected by the drive in the XAIN5 analog input. |   |

**M040 Speed Reference from Serial Link**

|             |                 |   |  |
|-------------|-----------------|---|--|
| <b>M040</b> | <b>Range</b>    | ± 32000 (integer part)<br>± 99 (decimal part)                 | ± 32000.99 rpm<br><u>Note:</u> The actual range depends on the selected motor, because it is defined by the value set in the parameters for the max. speed and min. speed of the selected motor.<br><b>C028–C029</b> Motor 1<br><b>C072–C073</b> Motor 2<br><b>C114–C115</b> Motor 3 |
|             | <b>Active</b>   | Always active.  |  |
|             | <b>Address</b>  | 1690 (integer part), 1691 (decimal part)                      |  |
|             | <b>Function</b> | This is the value of the speed reference set via serial link. |  |

**M042 Speed Reference from Fieldbus**

|             |                 |   |  |
|-------------|-----------------|---|--|
| <b>M042</b> | <b>Range</b>    | ± 32000 (integer part)<br>± 99 (decimal part)                   | ± 32000.99 rpm<br><u>Note:</u> The actual range depends on the selected motor, because it is defined by the value set in the parameters for the max. speed and min. speed of the selected motor.<br><b>C028–C029</b> Motor 1<br><b>C072–C073</b> Motor 2<br><b>C114–C115</b> Motor 3 |
|             | <b>Active</b>   | Always active.  |  |
|             | <b>Address</b>  | 1692 (integer part), 1693 (decimal part)                        |  |
|             | <b>Function</b> | This is the measure of the speed reference set by the fieldbus. |  |

**M044 Torque Reference from Serial Link**

|             |                 |  |  |
|-------------|-----------------|--|--|
| <b>M044</b> | <b>Range</b>    | ± 5000   | ± 500.0 %<br><u>Note:</u> The actual range depends on the torque limit value set for the selected motor.<br><b>C047–C048</b> Motor 1<br><b>C090–C091</b> Motor 2<br><b>C133–C134</b> Motor 3 |
|             | <b>Active</b>   | Always active.   |  |
|             | <b>Address</b>  | 1694   |  |
|             | <b>Function</b> | This is the measure of the torque reference set via serial link and expressed as a percentage of the rated torque of the selected motor. |  |

**M045 Torque Reference from Fieldbus**

|             |                 |  |   |
|-------------|-----------------|--|---|
| <b>M045</b> | <b>Range</b>    | ± 5000   | ± 500.0 %<br><u>Note:</u> The actual range depends on the torque limit values set for the selected motor.<br><b>C047–C048</b> Motor 1<br><b>C090–C091</b> Motor 2<br><b>C133–C134</b> Motor 3 |
|             | <b>Active</b>   | Always active.   |   |
|             | <b>Address</b>  | 1695   |   |
|             | <b>Function</b> | This is the measure of the torque reference set by the fieldbus and expressed as a percentage of the rated torque of the selected motor. |   |

**M046 PID Reference from Serial Link**

|             |                 |   |   |
|-------------|-----------------|---|---|
| <b>M046</b> | <b>Range</b>    | ±10000  | ±100.00 %<br><u>Note:</u> The actual range depends on the min. value and the max. value of the PID reference set in parameters:<br><b>P245–P246</b> |
|             | <b>Active</b>   | Always active.  |   |
|             | <b>Address</b>  | 1696  |   |
|             | <b>Function</b> | This is the measure of the PID reference set via serial link and expressed as a percentage. |   |

**M047 PID Reference from Fieldbus**

|             |                 |   |   |
|-------------|-----------------|---|---|
| <b>M047</b> | <b>Range</b>    | ±10000  | ±100.00 %<br><u>Note:</u> The actual range depends on the min. value and the max. value of the PID reference set in parameters:<br><b>P245–P246</b> |
|             | <b>Active</b>   | Always active.  |   |
|             | <b>Address</b>  | 1697  |   |
|             | <b>Function</b> | This is the measure of the PID reference set by the fieldbus and expressed as a percentage. |   |

**M048 PID Feedback from Serial Link**

|             |                 |  |  |
|-------------|-----------------|--|--|
| <b>M048</b> | <b>Range</b>    | ±10000   | ±100.00 %<br><u>Note:</u> The actual range depends on the min. value and the max. value of the PID feedback set in parameters:<br><b>P247–P248</b> |
|             | <b>Active</b>   | Always active.   |  |
|             | <b>Address</b>  | 1698   |  |
|             | <b>Function</b> | This is the measure of the PID feedback set via serial link and expressed as a percentage. |  |

**M049 PID Feedback from Fieldbus**

|             |                 |  |  |
|-------------|-----------------|--|--|
| <b>M049</b> | <b>Range</b>    | ±10000   | ±100.00 %<br><b>Note:</b> The actual range depends on the min. value and the max. value of the PID feedback set in parameters:<br><b>P247–P248</b> |
|             | <b>Active</b>   | Always active.   |  |
|             | <b>Address</b>  | 1699   |  |
|             | <b>Function</b> | This is the measure of the PID feedback set by the fieldbus and expressed as a percentage. |  |

**M050 Encoder Reference**

|             |                 |   |              |
|-------------|-----------------|---|--------------|
| <b>M050</b> | <b>Range</b>    | ± 32000   | ± 32000 rpm. |
|             | <b>Active</b>   | Always active.  |              |
|             | <b>Address</b>  | 1700  |              |
|             | <b>Function</b> | Reading of the encoder set as a reference source (see the ENCODER/FREQUENCY INPUTS MENU and the CONTROL METHOD MENU). |              |

**M051 Frequency Input Reference**

|             |                 |   |  |
|-------------|-----------------|---|--|
| <b>M051</b> | <b>Range</b>    | 1000 ÷ 10000  | 10000 ÷ 100000 Hz.<br><b>Note:</b> The actual range depends on the frequency min. value and max. value set in <b>P071-P072</b> . |
|             | <b>Active</b>   | Always active.  |  |
|             | <b>Address</b>  | 1701  |  |
|             | <b>Function</b> | Frequency readout in the digital input set as a reference source (see the ENCODER/FREQUENCY INPUTS MENU and the CONTROL METHOD MENU). |  |

**M051a RMS Input from AIN1 and AIN2**

|              |                 |  |                |
|--------------|-----------------|--|----------------|
| <b>M051a</b> | <b>Range</b>    | 0 ÷ 32000  | 0.00 ÷ 32.00 V |
|              | <b>Active</b>   | This measurement is active only if one of parameters among <b>C288</b> , <b>C289</b> or <b>C290</b> = 13: Vout measured.<br>Also, <b>P055</b> , <b>P060</b> = 0: ±10V.                   |                |
|              | <b>Address</b>  | 3374   |                |
|              | <b>Function</b> | RMS voltage obtained from instantaneous values of <b>AIN1</b> and <b>AIN2</b> if they are two sinusoidal voltage values having equal amplitude and frequency phase displacement of 120°. |                |

## 8.6. Outputs Menu

This menu allows checking the status of the digital outputs, the analog outputs and the frequency outputs located in the terminal board.

### M056 Digital Outputs

|             |                 |   |             |
|-------------|-----------------|---|-------------|
| <b>M056</b> | <b>Range</b>    | Bit-controlled measure.   | See Table 5 |
|             | <b>Active</b>   | Always active.  |             |
|             | <b>Address</b>  | 1706  |             |
|             | <b>Function</b> | Status of digital outputs MDO1÷4 and status of the precharge contactor. |             |

**Table 5: Coding of Measure M056**

| Bit n. | Digital Output                    |
|--------|-----------------------------------|
| 0      | MDO1/FOUT                         |
| 1      | MDO2                              |
| 2      | MDO3                              |
| 3      | MDO4                              |
| 6      | Status of the precharge contactor |

### M056a Virtual Digital Outputs

|              |                 |   |             |
|--------------|-----------------|---|-------------|
| <b>M056a</b> | <b>Range</b>    | Bit-controlled measure.                   | See Table 6 |
|              | <b>Active</b>   | Always active.                            |             |
|              | <b>Address</b>  | 1675                                      |             |
|              | <b>Function</b> | Status of virtual digital outputs MPL1÷4. |             |

**Table 6: Coding of Measure M056a**

| Bit n. | Digital Output |
|--------|----------------|
| 0      | MPL1           |
| 1      | MPL2           |
| 2      | MPL3           |
| 3      | MPL4           |

### M056b Timed Flags

|              |                 |                                 |             |
|--------------|-----------------|---------------------------------|-------------|
| <b>M056b</b> | <b>Range</b>    | Bit-controlled measure          | See Table 7 |
|              | <b>Active</b>   | Always active.                  |             |
|              | <b>Address</b>  | 1741                            |             |
|              | <b>Function</b> | Status of timed flags TFL1 ÷ 4. |             |

**Table 7: Coding of Measure M056b**

| Bit n. | Timed Flag |
|--------|------------|
| 0      | TFL1       |
| 1      | TFL2       |
| 2      | TFL3       |
| 3      | TFL4       |

**M057 Frequency Output**

|             |                 |   |   |
|-------------|-----------------|---|---|
| <b>M057</b> | <b>Range</b>    | 10000÷100000  | 10000 ÷ 100000 Hz<br><b>Note:</b> The actual range depends on the min. value and the max. value of MDO1 digital output set as a frequency reference. Values are set in <b>P204</b> and <b>P205</b> (see ANALOG AND FREQUENCY OUTPUTS MENU). |
|             | <b>Active</b>   | Always active.  |   |
|             | <b>Address</b>  | 1707  |   |
|             | <b>Function</b> | This is the frequency measure produced by MDO1 digital output when set as a frequency output. |   |

**M058 AO1 Analog Output**

|             |                 |  |        |
|-------------|-----------------|--|--------|
| <b>M058</b> | <b>Range</b>    | ±100   | ±100 % |
|             | <b>Active</b>   | Always active.   |        |
|             | <b>Address</b>  | 1708   |        |
|             | <b>Function</b> | Value percent of analog output AO1, referred to the preset max. output value (maximum absolute value between <b>P182</b> and <b>P183</b> , see ANALOG AND FREQUENCY OUTPUTS MENU). |        |

**M059 AO2 Analog Output**

|             |                 |   |        |
|-------------|-----------------|---|--------|
| <b>M059</b> | <b>Range</b>    | ±100  | ±100 % |
|             | <b>Active</b>   | Always active.  |        |
|             | <b>Address</b>  | 1709  |        |
|             | <b>Function</b> | Value percent of AO2 analog output referred to the preset max. output value (maximum absolute value between <b>P190</b> and <b>P191</b> , see ANALOG AND FREQUENCY OUTPUTS MENU). |        |

**M060 Analog Output AO3**

|             |                 |   |        |
|-------------|-----------------|---|--------|
| <b>M060</b> | <b>Range</b>    | ±100  | ±100 % |
|             | <b>Active</b>   | Always active.  |        |
|             | <b>Address</b>  | 1710  |        |
|             | <b>Function</b> | Value percent of AO3 analog output referred to the preset max. output value (maximum absolute value between <b>P198</b> and <b>P199</b> , see ANALOG AND FREQUENCY OUTPUTS MENU). |        |

**M061 Auxiliary Digital Outputs**

|             |                 |   |             |
|-------------|-----------------|---|-------------|
| <b>M061</b> | <b>Range</b>    | Bit-controlled measure.   | See Table 8 |
|             | <b>Active</b>   | Always active.  |             |
|             | <b>Address</b>  | 1711  |             |
|             | <b>Function</b> | Status of the auxiliary digital outputs located on the expansion board. |             |

**Table 8: Coding of Measure M061**

| Bit n. | Digital Output | Bit n. | Digital Output |
|--------|----------------|--------|----------------|
| 0      | XMDO1          | 3      | XMDO4          |
| 1      | XMDO2          | 4      | XMDO5          |
| 2      | XMDO3          | 5      | XMDO6          |

## 8.7. Temperature Measures from PT100 Menu

---

This menu displays the temperatures detected in the first four analog channels of the expansion board. Scaling complies with DIN EN 60751 for PT100: 100 ohm @ 0 °C and 0.385 ohm/°C.

**ES847 Expansion Board must be fitted on the equipment.**  
See also the EXPANSION BOARD CONFIGURATION MENU

### M069 PT100 Measure in Channel 1

|             |                 |  |                 |
|-------------|-----------------|--|-----------------|
| <b>M069</b> | <b>Range</b>    | -500 ÷2600   | -50.0 ÷260.0 °C |
|             | <b>Active</b>   | This measure is active only if programmed from parameter <b>R023</b> . |                 |
|             | <b>Address</b>  | 1719   |                 |
|             | <b>Function</b> | Temperature detected in analog channel 1.                              |                 |

### M070 PT100 Measure in Channel 2

|             |                 |  |                 |
|-------------|-----------------|--|-----------------|
| <b>M070</b> | <b>Range</b>    | -500 ÷2600   | -50.0 ÷260.0 °C |
|             | <b>Active</b>   | This measure is active only if programmed from parameter <b>R023</b> . |                 |
|             | <b>Address</b>  | 1720   |                 |
|             | <b>Function</b> | Temperature detected in analog channel 2.                              |                 |

### M071 PT100 Measure in Channel 3

|             |                 |  |                 |
|-------------|-----------------|--|-----------------|
| <b>M071</b> | <b>Range</b>    | -500 ÷2600   | -50.0 ÷260.0 °C |
|             | <b>Active</b>   | This measure is active only if programmed from parameter <b>R023</b> . |                 |
|             | <b>Address</b>  | 1721   |                 |
|             | <b>Function</b> | Temperature detected in analog channel 3.                              |                 |

### M072 PT100 Measure in Channel 4

|             |                 |  |                 |
|-------------|-----------------|--|-----------------|
| <b>M072</b> | <b>Range</b>    | -500 ÷2600   | -50.0 ÷260.0 °C |
|             | <b>Active</b>   | This measure is active only if programmed from parameter <b>R023</b> . |                 |
|             | <b>Address</b>  | 1722   |                 |
|             | <b>Function</b> | Temperature detected in analog channel 4.                              |                 |

## 8.8. Autodiagnosics Menu

This menu allows the user to check the functioning times and the relevant counters (for maintenance purposes) of the Penta drive; it also allows reading out the analog channels used for temperature sensors and the relevant temperature values, as well as the drive status.

### M052 / M054 Functioning Times

|                    |                 |  |                     |
|--------------------|-----------------|--|---------------------|
| <b>M052 / M054</b> | <b>Range</b>    | 0 ÷ 2147483647 (0 ÷ 7FFFFFFh)  | 0 ÷ 429496729.4 sec |
|                    | <b>Address</b>  | Supply Time: 1702-1703 (LSWord, MSWord)<br>Operation Time: 1704-1705 (LSWord, MSWord)  |                     |
|                    | <b>Function</b> | This screen displays the ST (supply time) and the OT (operation time).<br>The Operation Time is the activation time of the drive IGBTs.<br>Both values are expressed in 32 bits divided into two 16-bit words: the low part and the high part. |                     |

Functioning Times:

|   |   |   |   |   |   |   |   |   |   |   |   |   |
|---|---|---|---|---|---|---|---|---|---|---|---|---|
| S | u | p | p | l | y | T | i | m | e |   |   |   |
| M | 0 | 5 | 4 | = | 5 | 3 | : | 2 | 5 | : | 0 | 1 |
| O | p | e | r | a | t | i | o | n | T | i | m | e |
| M | 0 | 5 | 2 | = | 2 | 9 | : | 3 | 5 | : | 5 | 1 |

### M062 Ambient temperature Measure

|             |                 |   |            |
|-------------|-----------------|---|------------|
| <b>M062</b> | <b>Range</b>    | ± 32000   | ± 320.0 °C |
|             | <b>Active</b>   | Always active.  |            |
|             | <b>Address</b>  | 1712  |            |
|             | <b>Function</b> | Ambient temperature measured on the surface of the control board. |            |

### M064 IGBT Temperature Measure

|             |                 |   |            |
|-------------|-----------------|---|------------|
| <b>M064</b> | <b>Range</b>    | ± 32000   | ± 320.0 °C |
|             | <b>Active</b>   | Always active.  |            |
|             | <b>Address</b>  | 1714  |            |
|             | <b>Function</b> | Measure of the IGBT temperature.<br><br>If the temperature readout is <-30.0 °C or >150.0 °C, warning <b>W50 NTC Fault</b> appears.<br><br><u>Note:</u> Not all models are provided with the NTC sensor (see Table 17 in the PRODUCT MENU).<br>If this sensor is not provided, the measure is forced to 32,000, corresponding to +320.0 °C. |            |

**M065 Operation Time Counter**

|             |                 |  |           |
|-------------|-----------------|--|-----------|
| <b>M065</b> | <b>Range</b>    | 0÷65000  | 0÷650000h |
|             | <b>Active</b>   | Always active.   |           |
|             | <b>Address</b>  | 1715   |           |
|             | <b>Function</b> | Time elapsed after resetting the operation time counter. The Operation Time is the activation time of the drive IGBTs. |           |

**M066 Supply Time Counter**

|             |                 |   |           |
|-------------|-----------------|---|-----------|
| <b>M066</b> | <b>Range</b>    | 0÷65000   | 0÷650000h |
|             | <b>Active</b>   | Always active.  |           |
|             | <b>Address</b>  | 1716  |           |
|             | <b>Function</b> | Time elapsed after resetting the supply time counter. |           |

**M089 Drive Status**

|             |                 |   |  |
|-------------|-----------------|---|--|
| <b>M089</b> | <b>Range</b>    | See Table 131                                       |  |
|             | <b>Active</b>   | Always active.                                      |  |
|             | <b>Address</b>  | 1739  |  |
|             | <b>Function</b> | Describes the current condition of the Penta drive. |  |

**M090 Active Alarm**

|             |                 |                              |  |
|-------------|-----------------|------------------------------|--|
| <b>M090</b> | <b>Range</b>    | See Table 128                |  |
|             | <b>Active</b>   | Always active.               |  |
|             | <b>Address</b>  | 1740                         |  |
|             | <b>Function</b> | Alarm tripped at the moment. |  |

## 8.9. Data Logger Measures Menu

This menu displays the status of the types of connections (serial links, Ethernet and modem) supported by ES851 Data Logger board.

**This menu can be viewed only if the Data Logger board is fitted.**  
See also the DATA LOGGER MENU.

### M100 Data Logger Status (Line 3)

|                        |                       |  |   |
|------------------------|-----------------------|--|---|
| <b>M100<br/>Line 3</b> | <b>Range</b>          | 0 ÷ 2  | 0: NOT FITTED<br>1: OK not interlocked<br>2: OK interlocked |
|                        | <b>Active Address</b> | This measure is active only if programmed from parameter <b>R021</b> .<br>1336   |   |
|                        | <b>Function</b>       | <p><b>0: NOT FITTED</b>, ES851 is not installed on the Penta drive.</p> <p><b>1: OK not interlocked</b>, ES851 is operating independently of the drive where it is installed. To program ES851, a connection to a computer via the RemoteDrive software is required, or a special preset set via display/keypad is required (see the DATA LOGGER MENU).</p> <p><b>2: OK interlocked</b>, ES851 is ready to be configured even through the display/keypad of the drive where it is installed.</p> |   |

### M100 ES851 Fault (Line 4)

|                        |                       |   |  |
|------------------------|-----------------------|---|--|
| <b>M100<br/>Line 4</b> | <b>Range</b>          | 0 ÷ 6, 99 ÷ 104   | 0: No alarm<br>1: Parameter save fault<br>2: Log write error<br>3: FBS configuration failure<br>4: RS232 Modbus configuration failure<br>5: RS485 Modbus configuration failure<br>6: TCP/IP stack configuration failure<br>99: Flash card lacking or inaccessible<br>100: Invalid stream access<br>101: TCP/IP socket fault<br>102: Dial out connection failure<br>103: Control board clock failure<br>104: Modem initialization failure |
|                        | <b>Active Address</b> | This measure is active only if programmed from parameter <b>R021</b> .<br>1340  |  |
|                        | <b>Function</b>       | This indicates a general alarm tripped for ES851. In case an alarm trips, please contact ELETTRONICA SANTERNO's CUSTOMER SERVICE and mention the alarm code and name. |  |

**M101 Connection Status**

|             |                       |   |             |
|-------------|-----------------------|---|-------------|
| <b>M101</b> | <b>Range</b>          | Bit-controlled measure  | See Table 9 |
|             | <b>Active Address</b> | This measure is active only if programmed from parameter <b>R021</b> .  |             |
|             | <b>Function</b>       | 1338<br>Status of the connections supported by ES851. Note that the COM1 serial link is RS232 by default, whereas COM 2 is RS485 by default.<br>For more details, please refer to the Programming Guide manual for the Data Logger ES851. |             |

**Table 9: Data Logger connection status**

| Bit n. | Connection                         | Description   |
|--------|------------------------------------|---|
| 0-7    | Type of modem connection failure   | 0: None<br>1: Dial KO<br>2: Connect KO<br>3: Authentication KO<br>4: IPCP KO*<br>5: Modem not yet initialized<br>6: Modem init KO<br>7: Modem not configured<br>8: Modem not dial out<br>16: Connect end (echo time out)<br>32: Connect end (idle time out)<br>64: Connect end (term expired) |
| 8-10   | Status of the connection via modem | 0: No conn.<br>1: Dialing<br>2: Connecting<br>4: Connected<br>5: Attempt finished   |
| 11     | COM1                               | 0: No data exchange<br>1: Data exchanged  |
| 12     | COM2                               | 0: No data exchange<br>1: Data exchanged  |
| 13     | Ethernet                           | 0: No connection<br>1: Connection   |
| 14-15  | Reserved                           |   |

\* In computer networking, the **Internet Protocol Control Protocol (IPCP)** is a network control protocol for establishing and configuring Internet Protocol over a Point-to-Point Protocol link. The IPCP configures, enables, and disables the IP protocol modules on both ends of the point-to-point link.

## 8.10. Encoder Measures Menu

The Encoder Measures Menu displays the measures of the incremental and absolute position sensors (if any), as well as some useful info for managing those sensors.

### M120 Encoder A Count Value

|             |                 |  |  |
|-------------|-----------------|--|--|
| <b>M120</b> | <b>Range</b>    | 0 ÷ 65535  | 0 ÷ 65535<br><u>Note:</u> The actual range of this measure is based on the type of encoder being used. |
|             | <b>Active</b>   | Always active  |  |
|             | <b>Address</b>  | 1743   |  |
|             | <b>Function</b> | This is the count value of encoder A (see ENCODER/FREQUENCY INPUTS MENU).<br>When the inverter is powered on, the initial value is always 0. |  |

### M121 Encoder B Count Value

|             |                 |  |  |
|-------------|-----------------|--|--|
| <b>M121</b> | <b>Range</b>    | 0 ÷ 65535  | 0 ÷ 65535<br><u>Note:</u> The actual range of this measure is based on the type of encoder being used. |
|             | <b>Active</b>   | Always active  |  |
|             | <b>Address</b>  | 1744   |  |
|             | <b>Function</b> | This is the count value of encoder B (see ENCODER/FREQUENCY INPUTS MENU).<br>When the inverter is powered on, the initial value is always 0. |  |

### M122 Absolute Encoder Count Value

|             |                 |  |  |
|-------------|-----------------|--|--|
| <b>M122</b> | <b>Range</b>    | 0 ÷ 65535  | 0 ÷ 65535<br><u>Note:</u> The actual range of this measure is based on the type of encoder being used. |
|             | <b>Active</b>   | Always active  |  |
|             | <b>Address</b>  | 1747   |  |
|             | <b>Function</b> | This is the count value of the absolute encoder (or encoder M) (see ENCODER/FREQUENCY INPUTS MENU).<br>When the inverter is powered on, the initial value is always 0. |  |

## 8.11. Digital Input Settings Menu

This menu allows checking the functions assigned to the digital inputs.

**Table 10: Coding of the functions assigned to the digital inputs**

| Displayed Items | Function Assigned to the Digital Inputs            |
|-----------------|--|
| STOP            | Stop function                                      |
| REVERSE         | Startup with negative speed                        |
| EN-SW           | ENABLE SW  |
| DISABLE         | Drive disable                                      |
| Mspd0           | Multispeed 0                                       |
| Mspd1           | Multispeed 1                                       |
| Mspd2           | Multispeed 2                                       |
| Mspd3           | Multispeed 3                                       |
| CW/CCW          | Reversal of the direction of rotation              |
| DCB             | DC braking   |
| UP              | Reference increase                                 |
| DOWN            | Reference decrease                                 |
| UDReset         | Reset of speed setpoint due to UP/DOWN command     |
| Alarm 1         | Auxiliary trip 1                                   |
| Alarm 2         | Auxiliary trip 2                                   |
| Alarm 3         | Auxiliary trip 3                                   |
| MRmp0           | Multiramp 0  |
| MRmp1           | Multiramp 1  |
| JOG             | Jog mode   |
| SLAVE           | Selection of Slave Mode                            |
| PID Dis         | PID Disable  |
| KpdLock         | Display/keypad unit                                |
| Mot 2           | Selection of Motor 2                               |
| Mot 3           | Selection of Motor 3                               |
| Var 0           | Reference Variation 0                              |
| Var 1           | Reference Variation 1                              |
| Var 2           | Reference Variation 2                              |
| PID UDR         | PID Reference Reset due to UP/DOWN commands        |
| LOCAL           | Selection of Local mode                            |
| Brk Lock        | Mechanical brake locking                           |
| FireM           | Fire Mode enabled                                  |
| Src. Sel        | Reference/command source switch                    |
| nTlim           | External torque limit disable                      |
| START_B         | START function, terminals B                        |
| STOP_B          | STOP function, terminals B                         |
| REVERSE_B       | Startup with negative speed, terminals B           |
| MRef0           | PID Multireference 1                               |
| MRef1           | PID Multireference 2                               |
| MRef2           | PID Multireference 3                               |
| PID Csl         | PID Control Selection                              |
| START           | START function                                     |
| ENABLE          | ENABLE function                                    |
| RESET           | Alarm RESET  |
| EncA            | Encoder A Input                                    |
| EncB            | Encoder B Input                                    |
| FinA            | FINA Frequency input                               |
| FinB            | FINB Frequency input                               |
| Multi           | More than one function allocated to the same input |

## 8.12. Fault List Menu

Scroll the **Fault List Menu** to display the codes of the last eight alarms tripped.

Press the **SAVE/ENTER** key to access the alarm submenu and navigate to each value measured by the drive when the alarm tripped.

The diagram below shows a navigation example for the **Fault List Menu** (relating to alarm n.1 in particular). Note that n.1 is the last alarm tripped and n.8 is the first alarm tripped.

The measures marked with **Mxxx** are the same measures covered in this section.

If the Data Logger ES851 is installed (even the ES851 RTC version only) and parameter **R021** Data Logger is set to 2: ENABLE, the date and time when the alarm has tripped are displayed instead of the Supply Time (ST) and the Operation Time (OT) respectively.

Navigation Example - Fault List Menu.

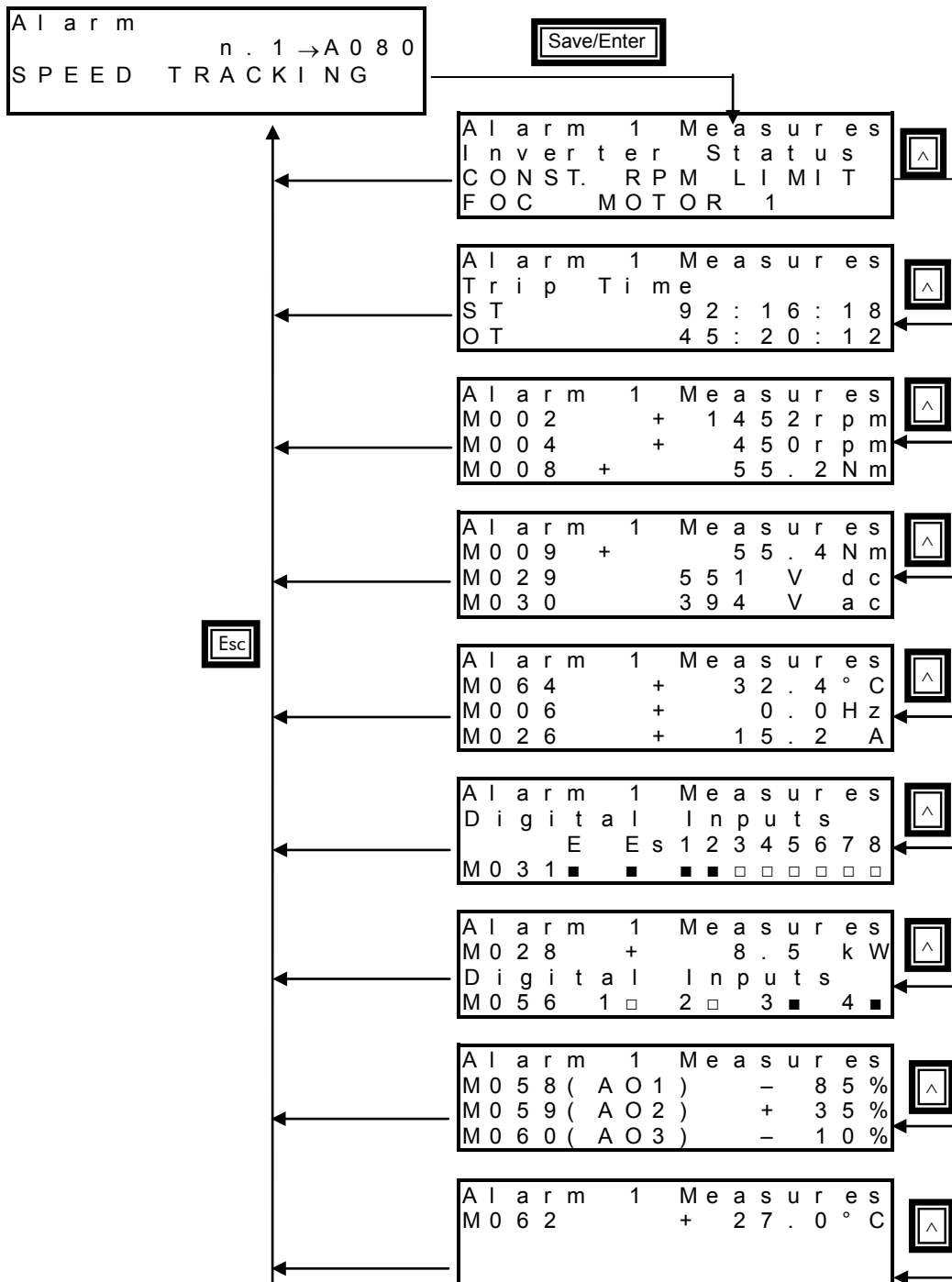

Table 11: Modbus base addresses in the Fault Lists

| Fault List | Modbus Base Address |
|------------|---------------------|
| FL1        | 7712                |
| FL2        | 7744                |
| FL3        | 7776                |
| FL4        | 7808                |
| FL5        | 7840                |
| FL6        | 7872                |
| FL7        | 7904                |
| FL8        | 7936                |

Table 12: List of the measures in the Fault Lists

| Measure | Function                      | Range                   | Value                         | Modbus Offset Address |
|---------|-------------------------------|-------------------------|-------------------------------|-----------------------|
| M090    | Active Alarm                  | See Table 128           | -                             | 0                     |
| M052    | Supply Time                   | See measure description | -                             | 1: LSW<br>2: MSW      |
| M054    | Operation Time                | See measure description | -                             | 3: LSW<br>4: MSW      |
| M089    | Inverter Status               | See Table 131           | -                             | 5                     |
| M026    | Output Current                | 0 ÷ 65535               | 0 ÷ 6553.5 A                  | 6                     |
| M004    | Motor Speed                   | ±32000                  | ±32000 rpm                    | 7                     |
| M002    | Speed Reference after Ramps   | ±32000                  | ±32000 rpm                    | 8                     |
| M008    | Torque Demand                 | ±32000                  | ±32000 Nm                     | 9                     |
| M009    | Torque Generated by the Motor | ±32000                  | ±32000 Nm                     | 10                    |
| M029    | DC-bus Voltage                | 0 ÷ 1400                | 0 ÷ 1400 V                    | 11                    |
| M030    | Grid Voltage                  | 0 ÷ 1000                | 0 ÷ 1000 V                    | 12                    |
| M064    | IGBT Temperature              | ±32000                  | ± 320.0 °C                    | 13                    |
| M006    | Inverter Output Frequency     | ±10000                  | ±1000.0 Hz                    | 14                    |
| M031    | Delayed Digital Inputs        | See measure description | -                             | 16                    |
| -       | Selected Motor (high byte)    | 0 ÷ 2                   | 0: Mot1<br>1: Mot2<br>2: Mot3 | 17                    |
| -       | Selected Control (low byte)   | 0 ÷ 2                   | 0: IFD<br>1: VTC<br>2: FOC    |                       |
| M028    | Output Power                  | 0 ÷ 65535               | 0 ÷ 6553.5 kW                 | 19                    |
| M056    | Digital Outputs               | See measure description |                               | 20                    |
| M058    | Analog output AO1             | ±100                    | ±100 %                        | 21                    |
| M059    | Analog output AO2             | ±100                    | ±100 %                        | 22                    |
| M060    | Analog output AO3             | ±100                    | ±100 %                        | 23                    |
| M062    | Ambient Temperature           | ±32000                  | ± 320.0 °C                    | 24                    |

To get the Modbus address of a given measure in a Fault List, sum up the base address to the measurement's offset.

Example:

The address of measure **M058** in Fault List **FL6** is as follows:

$$7872 + 21 = 7893$$

### 8.13. Power Off List Menu

This menu contains the measures of some characteristic variables detected at the drive power off, in conjunction with the alarm (if any) tripped at that moment.

Press the **SAVE/ENTER** key to access the submenu and navigate to the measures detected by the drive when the alarm tripped. Measures and codes are the same as the ones shown in the Fault List Menu.

If the Data Logger ES851 is installed (even the ES851 RTC version only) and parameter **R021** Data Logger is set to 2: ENABLE, the date and time when the alarm has tripped are displayed instead of the Supply Time (ST) and the Operation Time (OT) respectively.

The diagram below shows a navigation example for the **Power Off List**.

Navigation Example – PowerOff List Menu

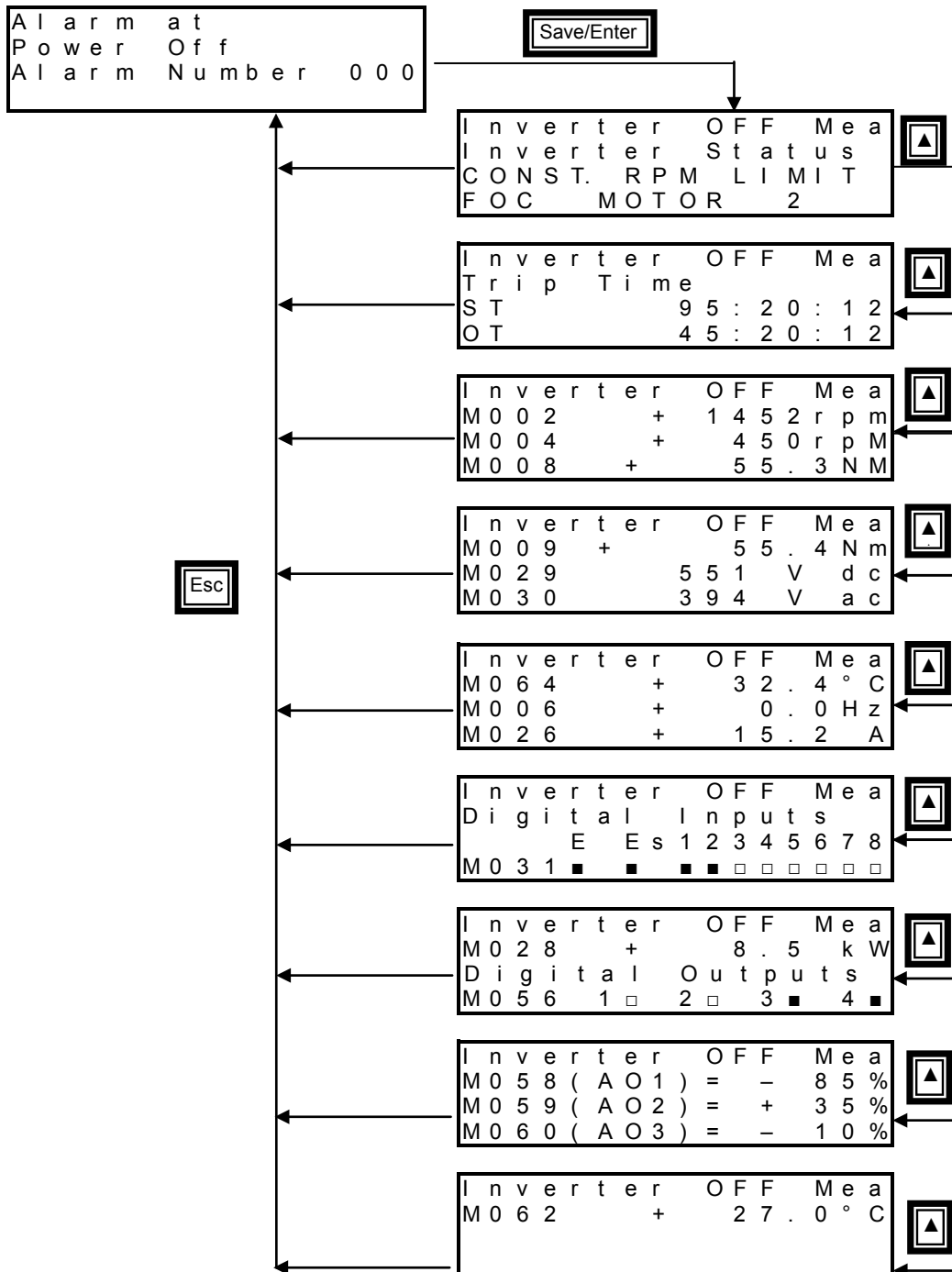

Table 13: List of the measures in the Power Off List

| Measure     | Function                      | Range                   | Value                         | Modbus Address         |
|-------------|-------------------------------|-------------------------|-------------------------------|------------------------|
| <b>M090</b> | Active Alarm                  | See Table 128           | -                             | 5044                   |
| <b>M052</b> | Supply Time                   | See measure description | -                             | 5045: LSW<br>5046: MSW |
| <b>M054</b> | Operation Time                | See measure description | -                             | 5047: LSW<br>5048: MSW |
| <b>M089</b> | Inverter Status               | See Table 131           | -                             | 5049                   |
| <b>M026</b> | Output Current                | 0 ÷ 65535               | 0 ÷ 6553.5 A                  | 5050                   |
| <b>M004</b> | Motor Speed                   | ±32000                  | ±32000 rpm                    | 5051                   |
| <b>M002</b> | Speed Reference after Ramps   | ±32000                  | ±32000 rpm                    | 5052                   |
| <b>M008</b> | Torque Demand                 | ±32000                  | ±32000 Nm                     | 5053                   |
| <b>M009</b> | Torque Generated by the Motor | ±32000                  | ±32000 Nm                     | 5054                   |
| <b>M029</b> | DC-bus Voltage                | 0 ÷ 1400                | 0 ÷ 1400 V                    | 5055                   |
| <b>M030</b> | Grid Voltage                  | 0 ÷ 1000                | 0 ÷ 1000 V                    | 5056                   |
| <b>M064</b> | IGBT Temperature              | ±32000                  | ± 320.0 °C                    | 5057                   |
| <b>M006</b> | Inverter Output Frequency     | ±10000                  | ±1000.0 Hz                    | 5058                   |
| <b>M031</b> | Delayed Digital Inputs        | See measure description | -                             | 5060                   |
| -           | Selected Motor (high byte)    | 0 ÷ 2                   | 0: Mot1<br>1: Mot2<br>2: Mot3 | 5061                   |
| -           | Selected Control (low byte)   | 0 ÷ 2                   | 0: IFD<br>1: VTC<br>2: FOC    |                        |
| <b>M028</b> | Output Power                  | 0 ÷ 65535               | 0 ÷ 6553.5 kW                 | 5063                   |
| <b>M056</b> | Digital Outputs               | See measure description |                               | 5064                   |
| <b>M058</b> | Analog output AO1             | ±100                    | ±100 %                        | 5065                   |
| <b>M059</b> | Analog output AO2             | ±100                    | ±100 %                        | 5066                   |
| <b>M060</b> | Analog output AO3             | ±100                    | ±100 %                        | 5067                   |
| <b>M062</b> | Ambient Temperature           | ±32000                  | ± 320.0 °C                    | 5068                   |

## 9. PRODUCT MENU

### 9.1. Overview

The Product Menu includes parameter **P263 Language**, allowing the user to select a dialog language; it also contains the Fire Mode enabling Password and the following information (read-only) about the product:

|                       |
|-----------------------|
| Product Name and Type |
| Implemented Software  |
| SW Versions           |
| Serial Number         |
| Manufacturer          |

### 9.2. List of Parameter P263 and Fire Mode Enable Password

Table 14: List of parameter P263 and Fire Mode Enable Password

| Parameter | FUNCTION                  | User Level | DEFAULT VALUE | MODBUS Address |
|-----------|---------------------------|------------|---------------|----------------|
| P263      | Language                  | BASIC      | 1:ENGLISH     | 863            |
|           | Fire Mode Enable Password | BASIC      | 0             | 868            |

#### P263 Language

|      |               |  |  |   |  |
|------|---------------|--|--|---|--|
| P263 | Range         | 0 ÷ 4  | 0: ITALIANO<br>1: ENGLISH<br>2: ESPAÑOL<br>3: PORTUGUES<br>4: DEUTSCH<br>(F1 version – standard) | 0: DANISH<br>1: ENGLISH<br>2: NORWEGIAN<br>3: FINNISH<br>4: SWEDISH<br>(F2 version – on demand) | 0: ITALIANO<br>1: ENGLISH<br>2: RUSSIAN<br>3: PORTUGUES<br>4: FRANÇAIS<br>(F3 version – on demand) |
|      | Default Level | 1  | 1: ENGLISH   |   |  |
|      | Address       | 863  |  |   |  |
|      | Function      | The dialog language is factory set to English. Use parameter <b>P263</b> to choose a different language.<br>The software implemented in the display/keypad is called MMI (man/machine interface); its version is displayed in the SW screen of the Product Menu. |  |   |  |



**CAUTION**

The available language set is that of standard version F1. Versions F2 and F3 are to be explicitly requested at the time when ordering the drive.

**Product Name and Type**

|                              |                 |   |   |
|------------------------------|-----------------|---|---|
| <b>Product Name and Type</b> | <b>Range</b>    | Fan control: bits 0 to 3<br>Voltage class: bits 4 to 7<br>Drive size: bits 8 to 15                | 0 ÷ 7 – see Table 18<br>0 ÷ 3 – see Table 16<br>0 ÷ 96 – see Table 15 |
|                              | <b>Address</b>  | Type: 1593  |   |
|                              | <b>Function</b> | This screen displays the name of the product (PENTA) and the type of product (see example below). |   |

```

P r o d u c t   N a m e
P E N T A
T y p e   0 0 2 0   4 T   - - -
    
```

The product name (PENTA) appears in the second line of the display/keypad. The third line shows the voltage class, the size of the drive and the type of fan control.

In the case shown in the example, the voltage class is 4T (400V), the size of the drive is 0020 and the fan operation is not controlled by the drive (character \_).

The numbers corresponding to the different models of the Penta Drive are given in the table below:

**Table 15: Indexes corresponding to the different models (sizes) of the Penta Drive**

| Index | Model | Index | Model | Index | Model | Index | Model | Index | Model |
|-------|-------|-------|-------|-------|-------|-------|-------|-------|-------|
| 0     | 0003  | 20    | 0023  | 40    | 0076  | 60    | 0259  | 80    | 0748  |
| 1     | 0004  | 21    | 0024  | 41    | 0086  | 61    | 0260  | 81    | 0749  |
| 2     | 0005  | 22    | 0025  | 42    | 0088  | 62    | 0290  | 82    | 0750  |
| 3     | 0006  | 23    | 0030  | 43    | 0113  | 63    | 0312  | 83    | 0800  |
| 4     | 0007  | 24    | 0032  | 44    | 0129  | 64    | 0313  | 84    | 0828  |
| 5     | 0008  | 25    | 0033  | 45    | 0131  | 65    | 0314  | 85    | 0831  |
| 6     | 0009  | 26    | 0034  | 46    | 0150  | 66    | 0366  | 86    | 0832  |
| 7     | 0010  | 27    | 0035  | 47    | 0162  | 67    | 0367  | 87    | 0850  |
| 8     | 0011  | 28    | 0036  | 48    | 0164  | 68    | 0368  | 88    | 0960  |
| 9     | 0012  | 29    | 0037  | 49    | 0172  | 69    | 0399  | 89    | 0964  |
| 10    | 0013  | 30    | 0038  | 50    | 0179  | 70    | 0401  | 90    | 0965  |
| 11    | 0014  | 31    | 0040  | 51    | 0180  | 71    | 0402  | 91    | 1128  |
| 12    | 0015  | 32    | 0042  | 52    | 0181  | 72    | 0457  | 92    | 1129  |
| 13    | 0016  | 33    | 0049  | 53    | 0200  | 73    | 0459  | 93    | 1130  |
| 14    | 0017  | 34    | 0051  | 54    | 0201  | 74    | 0523  | 94    | 1296  |
| 15    | 0018  | 35    | 0060  | 55    | 0202  | 75    | 0524  | 95    | 1800  |
| 16    | 0019  | 36    | 0062  | 56    | 0216  | 76    | 0526  | 96    | 2076  |
| 17    | 0020  | 37    | 0067  | 57    | 0217  | 77    | 0598  |       |       |
| 18    | 0021  | 38    | 0069  | 58    | 0218  | 78    | 0599  |       |       |
| 19    | 0022  | 39    | 0074  | 59    | 0250  | 79    | 0600  |       |       |

**Table 16: Voltage classes of the PD**

| Index | Class |
|-------|-------|
| 0     | 2T    |
| 1     | 4T    |
| 2     | 5T    |
| 3     | 6T    |

The type of fan control is marked by 3 characters:

Table 17: Fan control modes

| Character | Description  |
|-----------|--|
| F         | The fan activation is controlled by the inverter.  |
| S         | The fan operation is correct: when a fan fault is detected, the relevant alarm trips.  |
| N         | A NTC sensor is fitted, that acquires the heatsink temperature. The fan activation threshold is set in parameter <b>C264</b> . |

Table 18: Coding for fan activation

| Code | Symbol | Fan control | Fan status | NTC |
|------|--------|-------------|------------|-----|
| 0    | ---    | No          | No         | No  |
| 1    | -S-    | No          | Yes        | No  |
| 2    | F--    | Yes         | No         | No  |
| 3    | FS-    | Yes         | Yes        | No  |
| 4    | --N    | No          | No         | Yes |
| 5    | -SN    | No          | Yes        | Yes |
| 6    | F-N    | Yes         | No         | Yes |
| 7    | FSN    | Yes         | Yes        | Yes |

**SW Application**

| SW Application | Function | Description  |
|----------------|----------|--|
|                |          | This screen displays the type of software application which is implemented in the drive (e.g. Regenerative).<br>For the application software downloading instructions see the relevant User Manuals. |

**SW Versions**

| SW Versions | Range    | 0 ÷ 65535  | 0 ÷ 65.535 |
|-------------|----------|--|------------|
|             | Address  | Texas: 233<br>MMI: 1489<br>Motorola: 1487  |            |
|             | Function | This screen displays the SW versions implemented on the Penta drive:<br><b>Texas</b> → SW version of the DSP Texas<br><b>MMI</b> → SW version of the display/keypad<br><b>Motorola</b> → SW version of Motorola microprocessor |            |

**Maximum Output Frequency**

| Maximum Output Frequency | Range    | 0 ÷ 999   | 0 ÷ 999 |
|--------------------------|----------|---|---------|
|                          | Address  | 3327  |         |
|                          | Function | This screen displays the maximum allowable output frequency (Hz) for the drive. |         |

Serial Number

|                      |                 |  |             |
|----------------------|-----------------|--|-------------|
| <b>Serial Number</b> | <b>Range</b>    | 0 ÷ 9999999  | 0 ÷ 9999999 |
|                      | <b>Address</b>  | 1827-1828 (LSWord, MSWord)   |             |
|                      | <b>Function</b> | This is the serial number of the drive. The serial number is required when contacting ELETTRONICA SANTERNO's CUSTOMER SERVICE in order to activate the Fire Mode.<br>This measure is expressed in 32 bits divided into two 16-bit words: the low part and the high part. |             |

Fire Mode Enable Password

|                                  |                 |   |          |
|----------------------------------|-----------------|---|----------|
| <b>Fire Mode Enable Password</b> | <b>Range</b>    | 0 ÷ 9999  | 0 ÷ 9999 |
|                                  | <b>Default</b>  | 0   | 0        |
|                                  | <b>Level</b>    | BASIC   |          |
|                                  | <b>Address</b>  | 868   |          |
|                                  | <b>Function</b> | To enable the Fire Mode, please contact ELETTRONICA SANTERNO's CUSTOMER SERVICE and give the Serial Number of the drive where the Fire Mode is to be activated. Enter the password given by the Customer Service. |          |



**CAUTION** The Fire Mode Enable Password is set to 0 when the Restore Default is performed.

Manufacturer

|                     |                 |  |
|---------------------|-----------------|--|
| <b>Manufacturer</b> | <b>Function</b> | The name of Elettronica Santerno is displayed followed by Elettronica Santerno's website ( <a href="http://santerno.com">santerno.com</a> ). |
|---------------------|-----------------|--|

You can also send a Modbus query message to read the product ID.

Product ID

|                   |                 |   |           |
|-------------------|-----------------|---|-----------|
| <b>Product ID</b> | <b>Range</b>    | 1 ÷ 65535   | 1 ÷ 65535 |
|                   | <b>Address</b>  | 476   |           |
|                   | <b>Function</b> | You can read the product ID from address 476. The eight high bits give the first character of the ID, the eight low bits give the second character of the product ID.<br>E.g. for PD (Penta Drive):<br>MODBUS value read from address 476: 20548d → 0x5044H<br>50H → Character 'P'<br>44H → Character 'D' |           |

## 10. PASSWORD AND USER LEVEL MENU

### 10.1. Overview

The Password and User Level menu allows changing the programming parameters and sets their visibility.

- **P000** enables parameter modification
- **P001** sets the user level
- **P002** allows to change the password set in **P000**
- **P003** conditions required to change C parameters

### 10.2. List of Parameters P000 to P003

Table 19: List of parameters P000 to P003

| Parameter   | FUNCTION                                   | User Level  | DEFAULT VALUES  | MODBUS Address |
|-------------|--|-------------|-----------------|----------------|
| <b>P000</b> | Write enable                               | BASIC       | 00001           | 513            |
| <b>P001</b> | Programming level                          | BASIC       | 0:[Basic]       | 514            |
| <b>P002</b> | Write enable password                      | ENGINEERING | 00001           | 510            |
| <b>P003</b> | Conditions required to change C parameters | ADVANCED    | StandBy+Fluxing | 509            |

#### P000 Write Enable

Factory setting is **P000 = 1** (parameter write is enabled). To access parameter **P000** allowing parameter write, access the Password and User Level Menu from the Parameters Menu.

| <b>P000</b> | Range    | 00000+32767   | 00000: [No] +32767 |
|-------------|----------|---|--------------------|
|             | Default  | 00001   | 00001              |
|             | Level    | BASIC   |                    |
|             | Address  | Cannot be accessed via serial link.<br>Parameter write via serial link is always enabled.   |                    |
|             | Function | Set the correct value in <b>P000</b> to enable parameter write.<br>The default password for <b>P000</b> is 00001.<br>You can enter a custom password in <b>P002</b> . |                    |

**P001 User Level**

|             |                 |   |   |
|-------------|-----------------|---|---|
| <b>P001</b> | <b>Range</b>    | 0÷2   | 0: Basic<br>1: Advanced<br>2: Engineering |
|             | <b>Default</b>  | 0   | 0 : Basic                                 |
|             | <b>Level</b>    | BASIC   |   |
|             | <b>Address</b>  | 514   |   |
|             | <b>Function</b> | <p>The inverter programming parameters are grouped by access levels based on their functions (more or less complex functions).<br/>Some menus, or some parts of menus, are not displayed when a given access level is selected.<br/>When the BASIC access level is selected once the inverter parameterization is correct, navigation is easier, as only frequently accessed parameters are displayed.<br/>The User Level is stated for each parameter.</p> |   |

**P002 Password for Write Enable**

|             |                 |   |               |
|-------------|-----------------|---|---------------|
| <b>P002</b> | <b>Range</b>    | 00001 ÷ 32767   | 00001 ÷ 32767 |
|             | <b>Default</b>  | 00001.  |               |
|             | <b>Level</b>    | ENGINEERING   |               |
|             | <b>Address</b>  | 510   |               |
|             | <b>Function</b> | Once write is enabled after entering the correct password in <b>P000</b> , you can use parameter P002 to enter a custom password. |               |



**CAUTION** The new password allowing parameter write is the value entered in **P002**. Note it down and keep it handy!

**P003 Conditions for C Parameter Modifications**

|             |                 |   |   |
|-------------|-----------------|---|---|
| <b>P003</b> | <b>Range</b>    | 0 ÷ 1   | 0:[Stand-by only] ÷ 1:[StandBy+Fluxing] |
|             | <b>Default</b>  | 1   | 1:[StandBy+Fluxing]                     |
|             | <b>Level</b>    | ADVANCED  |   |
|             | <b>Address</b>  | 509   |   |
|             | <b>Function</b> | <p>Factory setting allows <b>C parameters</b> to be programmed even when the inverter is enabled. However, the motor must be stopped. If <b>P003=0: [Stand-by only]</b>, C parameters can be changed only when the inverter is disabled.<br/>This parameter also affects the behaviour of the digital inputs for <b>LOC/REM</b> and motor selection: when those inputs change, they produce their effect only when C parameters are allowed to be changed, according to the value in <b>P003</b>.</p> |   |



**CAUTION** If **P003 = 1:[StandBy+Fluxing]** when changing a C parameter, the drive automatically disables (stops modulating) and the motor starts idling.



**NOTE** If **C010 = 0: IFD [Voltage/Frequency]**, C parameters may be set up when the **ENABLE-A** and **ENABLE-B** inputs are active and the motor is stopped independently of **P003**.

## 11. DISPLAY/KEYPAD MENU

### 11.1. Overview

---

**NOTE**

It is recommended that the “Operating and Remoting the Keypad” section in the Sinus Penta’s Installation Guide be read as well.

The Display/Keypad Menu contains programming parameters to do the following:  
 Set the navigation mode within the drive menus;  
 Select the Root Page;  
 Select measures from the Root Page and the Keypad Page;  
 Select the type of Keypad Page displayed in Local mode;  
 Set custom PID units of measure;  
 Disable the **LOC/REM** or **FWD/REV** keys in the keypad.

The Root Page, the Keypad Page and Local mode are detailed in the following sections.

### 11.2. Root Page

---

|   |   |   |   |   |   |   |   |   |   |   |   |         |
|---|---|---|---|---|---|---|---|---|---|---|---|---------|
|   | I | N | V | E | R | T | E | R |   | O | K |         |
| → |   |   | + |   | 1 | 5 | 0 | 0 | . | 0 | 0 | r p m   |
| → |   |   | + |   |   |   |   |   | 0 | . | 0 | r p m   |
|   | M | E | A |   | P | A | R |   | C | F | [ | I D P ] |

The Root page is factory-set as the startup page to be displayed when the drive is turned on.

**NOTE**

You can access the four main menus only from the root page:

**MEA** → Measures;  
**PAR** → Programming parameters;  
**CF** → Configuration parameters;  
**IDP** → Product identification.

Line 1 on this page displays the drive operating status (see the description of parameter **M089**).

**Lines 2 and 3 display two measures which may be selected with parameters P268, P268a. These measures can be scaled through parameters P268y and P268z.**

Line 4 displays the four main menus of the drive. The selected menu is displayed in square brackets: use the ▲ and ▼ keys to select a different menu. Press the **SAVE/ENTER** key to access the selected menu.

### 11.3. Keypad Page and Local Mode

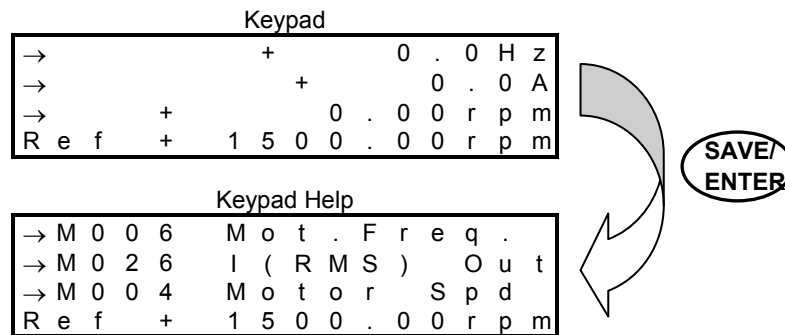

To access the Keypad pages, press the **MENU** key from the Root Page or press the **LOC/REM** key after selecting the Local mode.

The measures displayed on the Keypad page can be set up through parameters **P268b** to **P268e**. From the Keypad page, press the **SAVE/ENTER** key to display the Keypad Help page, describing the measures displayed on the Keypad page. The Keypad Help page is displayed for a few seconds.



**NOTE**

If parameter **P264b** (Navigation mode via **MENU** key) is set to Operator, navigation is locked once the Keypad Page is displayed. Hold down the **ESC** key for a few seconds to resume navigation.

The following Keypad Pages are available:

- Measures only → four lines displaying measures only
- Speed → line 4 shows the speed reference, that can be changed with the ▲ and ▼ keys.
- Torque → line 4 shows the torque reference, that can be changed with the ▲ and ▼ keys.
- Limit Torque → line 4 shows the limit torque reference, that can be changed with the ▲ and ▼ keys.
- PID → line 4 shows the PID reference, that can be changed with the ▲ and ▼ keys.

If the Local Mode is NOT selected, pressing the MENU key allows viewing only the pages containing the references sent via keypad (see the CONTROL METHOD MENU and the PID CONFIGURATION MENU).

**LOCAL MODE**

In **LOCAL** mode (the L-CMD and L-REF LEDs come on when the Local mode is active), only the commands and references sent via keypad are enabled, while any other control source or reference source is disabled (see the CONTROL METHOD MENU, the DIGITAL INPUTS MENU and the INPUTS FOR REFERENCES MENU). The keypad page displayed when the **LOC/REM** key is pressed depends on the setting of parameter **P266** (Type of Keypad Page in Local Mode):

**P266 = Measures Only** → Page containing 4 preset measures; no reference can be changed.

**P266 = Ref.Activated** → Line 4 in the Keypad Page enables changing the drive reference: the speed reference if a speed control is activated (“Ref” displayed), the torque reference if a torque control is activated (“TRef” displayed). If the drive reference is the PID output (**C294** PID Action = 1:[Reference]), the PID reference is given (“PRef” displayed). Use the ▲ and ▼ keys to change the reference displayed in line 4 on the Keypad Page.

**P266 = Ref.Activated+Spd** → To be used only when the drive reference depends on the PID output when a speed control is used (**C294** PID Action = 1:[Reference]). When the **LOC/REM** key is pressed for the first time, “PRef” is displayed in line 4 and the PID reference may be adjusted; when the **LOC/REM** key is pressed twice, the PID is disabled and the speed reference can be changed (“Ref” displayed). Use the ▲ and ▼ keys to change the reference shown in line 4 on the Keypad Page.

## 11.4. List of Parameters P264 to P269b

Table 20: List of parameters P264 to P269b

| Parameter    | FUNCTION                                 | User Level  | DEFAULT SETTING           | MODBUS Address     |
|--------------|--|-------------|---------------------------|--------------------|
| <b>P264</b>  | Navigation mode                          | ADVANCED    | 0 :[BY MENU]              | 864                |
| <b>P264a</b> | Circular navigation                      | ADVANCED    | 1: [YES]                  | 865                |
| <b>P264b</b> | Navigation mode with the <b>MENU</b> key | ADVANCED    | 0:[STANDARD]              | 512                |
| <b>P265</b>  | Root page                                | ADVANCED    | 3: [Start Up]             | 866                |
| <b>P266</b>  | Type of Keypad page in Local Mode        | ADVANCED    | 1:[Ref.Activated]         | 511                |
| <b>P267</b>  | Preset PID units of measure              | ENGINEERING | 0:[Disable]               | 867                |
| <b>P267a</b> | Custom PID units of measure              | ENGINEERING | [%]                       | 1867               |
| <b>P267b</b> | Preset PID2 units of measure             | ENGINEERING | 0:[Disable]               | 861                |
| <b>P267c</b> | Custom PID2 units of measure             | ENGINEERING | [%]                       | 1869               |
| <b>P268</b>  | Measure n.1 on Root page                 | ADVANCED    | <b>M004</b> Motor Spd     | cannot be accessed |
| <b>P268y</b> | Scaling of Measure n.1 on Root page      | ADVANCED    | 100.00%                   | 515                |
| <b>P268a</b> | Measure n.2 on Root page                 | ADVANCED    | <b>M000</b> Speed Ref.    | cannot be accessed |
| <b>P268z</b> | Scaling of Measure n.2 on Root page      | ADVANCED    | 100.00%                   | 516                |
| <b>P268b</b> | Measure n.1 on Keypad page               | ADVANCED    | <b>M006</b> Mot.Freq.     | cannot be accessed |
| <b>P268c</b> | Measure n.2 on Keypad page               | ADVANCED    | <b>M026</b> Motor Current | cannot be accessed |
| <b>P268d</b> | Measure n.3 on Keypad page               | ADVANCED    | <b>M004</b> Motor Spd     | cannot be accessed |
| <b>P268e</b> | Measure n.4 on Keypad page               | ADVANCED    | <b>M000</b> Speed Ref.    | cannot be accessed |
| <b>P269</b>  | Disable <b>LOC/REM FWD/REV</b> keys      | ENGINEERING | [NO NO]                   | 869                |
| <b>P269b</b> | <b>ESC</b> key to restore previous value | ENGINEERING | [NO]                      | 1051               |

### P264 Navigation Mode

|             |                 |  |   |
|-------------|-----------------|--|---|
| <b>P264</b> | <b>Range</b>    | 0 ÷ 2  | 0: By Menu<br>1: Changed Pars Only<br>2: Linear |
|             | <b>Default</b>  | 0  | 0: By Menu                                      |
|             | <b>Level</b>    | ADVANCED   |   |
|             | <b>Address</b>  | 864  |   |
|             | <b>Function</b> | Navigation by menu is factory-set and is activated whenever the Penta drive is powered on.<br>Set <b>P264</b> =1:[Changed Pars Only] to navigate only through the parameters whose default values have been changed.<br>In that case, linear navigation becomes active: only the parameters that have been changed are displayed in sequence. Press the ▲ and ▼ keys to go to a different parameter. Navigation is slower if only few parameters have been changed.<br>Set <b>P264</b> =2:[Linear] to display parameters in sequence using the ▲ and ▼ keys. If Linear navigation is selected, parameters are no longer divided into menus and submenus. |   |



**NOTE**

This parameter cannot be saved. Navigation by menu is restored whenever the drive is powered on.

**P264a Circular Navigation**

|              |                 |   |                     |
|--------------|-----------------|---|---------------------|
| <b>P264a</b> | <b>Range</b>    | 0 ÷ 1   | 0: [NO]<br>1: [YES] |
|              | <b>Default</b>  | 1   | 1: [YES]            |
|              | <b>Level</b>    | ADVANCED  |                     |
|              | <b>Address</b>  | 865   |                     |
|              | <b>Function</b> | <p>Parameter <b>P264a</b> is factory set to 1:[YES]. This means that “wrap” navigation is activated: navigation starts from the first page of the selected menu. Press ▲ to go to the next page. When the last page is displayed, press ▲ again to <u>return to the first page of the selected menu</u>.</p> <p>From the first page of the selected menu, press ▼ to go to the last page of the active menu.</p> <p>If <b>P264a</b>=0: [NO], when the last page of the active menu is displayed, the ▲ key is disabled; you can only view the previous pages—up to the first page of the active menu—by pressing the ▼ key.</p> |                     |

**P264b Navigation Mode with the MENU Key**

|              |                 |  |                                |
|--------------|-----------------|--|--------------------------------|
| <b>P264b</b> | <b>Range</b>    | 0 ÷ 1  | 0: [STANDARD]<br>1: [OPERATOR] |
|              | <b>Default</b>  | 0  | 0: [STANDARD]                  |
|              | <b>Level</b>    | ADVANCED   |                                |
|              | <b>Address</b>  | 512  |                                |
|              | <b>Function</b> | <p>Press the <b>MENU</b> key from any parameter to go to the access page of the menu containing that parameter; press the <b>MENU</b> key again to go to the Root page; press the <b>MENU</b> key again to go to the Keypad page.</p> <p>If factory setting is active (<b>P264b</b>=0: [STANDARD]) press the <b>MENU</b> key from the Keypad page to go to the Root page, then to the starting parameter. If <b>P264b</b>=1: [OPERATOR], navigation is locked once the Keypad Page is displayed. Hold down the <b>ESC</b> key for a few seconds to resume navigation. This prevents inexperienced users from navigating through the parameters stored to the keypad. If the Keypad page is preset as the startup page (<b>P265</b>=1: [Measures]) and <b>P264b</b>=1 :[OPERATOR], navigation is always locked.</p> |                                |

**P265 Startup Page**

|             |                 |   |  |
|-------------|-----------------|---|--|
| <b>P265</b> | <b>Range</b>    | 0 ÷ 3   | 0: [Root]<br>1: [Measures]<br>2: [Keypad]<br>3: [Start-Up] |
|             | <b>Default</b>  | 3   | 3: [Start-Up]  |
|             | <b>Level</b>    | ADVANCED  |  |
|             | <b>Address</b>  | 866   |  |
|             | <b>Function</b> | <p><b>P265</b> sets the page to be displayed when the drive is turned on.</p> <p><b>P265</b> = 0: the Root page is the startup page.</p> <p><b>P265</b> = 1: the Keypad Page displaying 4 measures only is the startup page.</p> <p><b>P265</b> = 2: The Keypad page displaying a reference in line 4 is the startup page.</p> <p><b>P265</b> = 3: the START-UP MENU is the startup page.</p> |  |

**P266 Type of Keypad Page in Local Mode**

|             |                 |   |  |
|-------------|-----------------|---|--|
| <b>P266</b> | <b>Range</b>    | 0 ÷ 2   | 0: [Measures Only]<br>1: [Ref.Activated]<br>2: [Ref.Activated+Speed] |
|             | <b>Default</b>  | 1   | 1: [Ref.Activated]   |
|             | <b>Level</b>    | ADVANCED  |  |
|             | <b>Address</b>  | 511   |  |
|             | <b>Function</b> | <p><b>P266</b> sets the type of keypad page to be displayed in Local mode.</p> <p>If <b>P266 = 0: [Measures Only]</b> in Local mode, the reference cannot be changed.</p> <p>If <b>P266 = 1: [Ref.Activated]</b> in Local mode, the Keypad page containing the activated reference is displayed; for example, if a torque control is active, the Keypad page displayed in Local mode shows the torque reference in line 4. Use the ▲ and ▼ keys to change the torque reference.</p> <p>If a speed control is active and the drive reference is the PID output (<b>C294</b> PID Action = 1: [Reference]), when in Local mode, you should disable the PID regulator and send a speed reference from keypad (to do so, set <b>P266 = 2: [Ref.Activated+Speed]</b>).</p> <p>When pressing the <b>LOC/REM</b> key to enter the Local mode, the Keypad page containing the PID reference is displayed. Use the ▲ and ▼ keys to change the PID reference.</p> <p>Press the <b>LOC/REM</b> key once again (when the drive is disabled) to disable the PID control. The Keypad page containing the speed reference is displayed. Use the ▲ and ▼ keys to change the speed reference.</p> |  |

**P267 Preset PID/PID2 Units of Measure**

|             |                 |   |              |
|-------------|-----------------|---|--------------|
| <b>P267</b> | <b>Range</b>    | 0 ÷ 34  | See Table 21 |
|             | <b>Default</b>  | 0   | 0: [Disable] |
|             | <b>Level</b>    | ENGINEERING   |              |
|             | <b>Address</b>  | 867/861   |              |
|             | <b>Function</b> | <p>The PID/PID2 reference and PID/PID2 feedback are expressed as a percentage in measures <b>M020, M021, M020a, M021a</b>.</p> <p>Parameters <b>P257/P457</b> allow setting a gain value to “scale” the PID reference and PID feedback and to obtain the following measures:</p> <p><b>M023 = P257 * M020;</b><br/><b>M024 = P257 * M021</b></p> <p>which are properly scaled. Parameters <b>P267/P267b</b> (see coding of <b>P267/P267b</b>) sets the unit of measure for the measures above; the unit of measure can also be entered in parameter <b>P267a/P267c</b> (only if <b>P267/P267b = 0: [Disable]</b>).</p> <p>Example: the PID reference is 100%; <b>M020 = 100%</b>; if <b>P257 = 0.04</b> and <b>P267 = 1: [bars]</b>, the scaled measure for the PID reference is → <b>M023 = 4.00 bars</b>.</p> |              |

Table 21: Preset PID units of measure

| Unit of Measure     | P267/P267b  | Item Displayed  | Unit of measure      | P267/P267b | Item Displayed |
|---------------------|-------------|-----------------|----------------------|------------|----------------|
| Customized          | 0: Disabled | ----(see P267a) | m                    | 18: m      | m              |
| bar                 | 1: bar      | bar             | ft                   | 19: ft     | ft             |
| mbar                | 2: mbar     | mbar            | m/s                  | 20: m/s    | m/s            |
| atm                 | 3:atm       | atm             | ft/s                 | 21: ft/s   | ft/s           |
| Pa                  | 4: Pa       | Pa              | rpm                  | 22: rpm    | rpm            |
| kPa                 | 5: kPa      | kPa             | gal/s                | 23: GPS    | GPS            |
| PSI                 | 6: PSI      | PSI             | gal/min              | 24: GPM    | GPM            |
| m <sup>3</sup> /s   | 7: m3/s     | m3/s            | gal/h                | 25: GPH    | GPH            |
| m <sup>3</sup> /min | 8: m3/m     | m3/m            | ft <sup>3</sup> /s   | 26: CFS    | CFS            |
| m <sup>3</sup> /h   | 9: m3/h     | m3/h            | ft <sup>3</sup> /min | 27: CFM    | CFM            |
| l/s                 | 10: l/s     | l/s             | ft <sup>3</sup> /h   | 28: CFH    | CFH            |
| l/min               | 11: l/m     | l/m             | A                    | 29: A      | A              |
| l/h                 | 12: l/h     | l/h             | V                    | 30: V      | V              |
| °                   | 13: °       | °               | W                    | 31: W      | W              |
| °C                  | 14: °C      | °C              | kW                   | 32: kW     | kW             |
| °F                  | 15: °F      | °F              | HP                   | 33: HP     | HP             |
| Nm                  | 16: Nm      | Nm              | CV                   | 34: CV     | CV             |
| kgm                 | 17: kgm     | kgm             |                      |            |                |

**P267a/P267c Custom PID/PID2 Units of Measure**

|              |                 |  |  |
|--------------|-----------------|--|--|
| <b>P267a</b> | <b>Range</b>    | 0x20 ÷ 0x8A (every byte)   | ASCII 0x20 = blank<br>ASCII 0x8A = □   |
|              | <b>Default</b>  | 0x015D255B   | ASCII 0x5D = [<br>ASCII 0x25 = %<br>ASCII 0x5B = ]<br>⇒ [%]  |
|              | <b>Level</b>    | ENGINEERING  |  |
|              | <b>Address</b>  | 1867/1869  | (This is a 32-bit data item)<br>Characters are 8-bit ASCII encoded; there are three 8-bit characters starting from the less significant bit. Bit 24 must always be set to 1. |
|              | <b>Function</b> | Parameter <b>P267a/P267c</b> is active only if <b>P267/P267b</b> = 0: [Disable] and it relates to the unit of measure actually displayed in <b>M023, M024, M023a, M024a</b> . This parameter allows setting a 3-character string to display the units of measures for the PID Measures: <b>M023, M024, M023a, M024a</b> .<br>Press the <b>SAVE/ENTER</b> key to edit each character: when a flashing cursor appears on the left of each character, press <b>▲</b> and <b>▼</b> to scroll all the characters displayed. Press the <b>ESC</b> key to go to the next character. Press <b>SAVE/ENTER</b> to store the new parameter value. |  |



**NOTE** See also parameter **P257/P457** in the PID PARAMETERS MENU.

**P268 (P268a) Measure n.1 (n.2) on Root Page**

|                     |                 |   |
|---------------------|-----------------|---|
| <b>P268 / P268a</b> | <b>Range</b>    | <b>M000 ÷ M056b</b> (see MEASURES MENU and Table 59)                                |
|                     | <b>Default</b>  | <b>P268</b> → <b>M004</b> Motor Spd<br><b>P268a</b> → <b>M000</b> Speed Ref.        |
|                     | <b>Level</b>    | ADVANCED  |
|                     | <b>Address</b>  | Cannot be accessed via serial link.   |
|                     | <b>Function</b> | These two parameters allow selecting two measures to be displayed on the Root Page. |

**P268y (P268z) Scaling of Measure n.1 (n.2) on Root Page**

|                      |                 |  |             |
|----------------------|-----------------|--|-------------|
| <b>P268y / P268z</b> | <b>Range</b>    | 0 ÷ 10000  | 0 ÷ 100.00% |
|                      | <b>Default</b>  | 10000  | 100.00%     |
|                      | <b>Level</b>    | ADVANCED   |             |
|                      | <b>Address</b>  | 515 / 516  |             |
|                      | <b>Function</b> | These parameters allow scaling the read-out of the measures on the Root page which have been selected with parameters <b>P268</b> and <b>P268a</b> . |             |

**P268b (P268c, P268d, P268e) Measure n.1 (n.2, n.3, n.4) on Keypad Page**

|                                   |                 |   |
|-----------------------------------|-----------------|---|
| <b>P268b, P268c, P268d, P268e</b> | <b>Range</b>    | <b>M000 ÷ M056b</b> (see MEASURES MENU and Table 59)  |
|                                   | <b>Default</b>  | <b>P268b</b> → <b>M006</b> Mot.Freq.<br><b>P268c</b> → <b>M026</b> Motor Current<br><b>P268d</b> → <b>M004</b> Motor Spd<br><b>P268e</b> → <b>M000</b> Speed Ref. |
|                                   | <b>Level</b>    | ADVANCED  |
|                                   | <b>Address</b>  | Cannot be accessed via serial link.   |
|                                   | <b>Function</b> | These four parameters allow selecting four measures to be displayed on the Keypad Page.   |

**NOTE**

Measure n. 4 is available in the measure Keypad page only. The reference to measure n. 4 is available for the remaining Keypad pages.

**P269 Disable LOC/REM FWD/REV Keys**

|             |                 |   |                         |
|-------------|-----------------|---|-------------------------|
| <b>P269</b> | <b>Range</b>    | 0 ÷ 3   | 0:[No No] - 3:[YES YES] |
|             | <b>Default</b>  | 0   | 0:[No No]               |
|             | <b>Level</b>    | ENGINEERING   |                         |
|             | <b>Address</b>  | 869   |                         |
|             | <b>Function</b> | This parameter allows disabling the <b>LOC/REM</b> and/or the <b>FWD/REV</b> key. This is a bit-controlled parameter: bit 0 relates to <b>LOC/REM</b> , while bit 1 relates to <b>FWD/REV</b> . Set 0 to select [NO], set 1 to select [Yes].<br><b>P269</b> = 0 → both keys are enabled.<br><b>P269</b> = 1 → the <b>LOC/REM</b> key is disabled.<br><b>P269</b> = 2 → the <b>FWD/REV</b> key is disabled.<br><b>P269</b> = 3 → both keys are disabled. |                         |

## P269b ESC Key to Restore Previous Value

|              |                 |  |                  |
|--------------|-----------------|--|------------------|
| <b>P269b</b> | <b>Range</b>    | 0 ÷ 1  | 0:[No] - 1:[YES] |
|              | <b>Default</b>  | 0  | 0:[No]           |
|              | <b>Level</b>    | ENGINEERING  |                  |
|              | <b>Address</b>  | 1051   |                  |
|              | <b>Function</b> | <p>Effect of pressing the <b>ESC</b> key when changing a parameter after pressing <b>SAVE/ENTER</b>:</p> <p><b>P269b = 0:[No]</b> → press <b>ESC</b> to confirm the parameter value, which is not stored non-volatile memory (the previous value will be restored when the drive is next powered on).</p> <p><b>P269b = 1:[YES]</b> → press <b>ESC</b> to restore the previous value.</p> <p>In both cases, press <b>SAVE/ENTER</b> to confirm the new parameter value and store it to non-volatile memory (the new value is still effective when the drive is next powered on).</p> |                  |

## 12. RAMPS MENU

### 12.1. Overview

---

An acceleration/deceleration ramp is a function allowing linear variations of the motor speed.

The ramp time is the time the motor takes to reach its max. speed when it starts from zero speed (or the time the motor takes to reach 0 speed when decelerating).

Four pairs of programmable values are available. Each pair defines the motor acceleration time and deceleration time. The unit of measure of the basic time period is assigned to each pair of values.

In the Ramps menu, you can set the acceleration and deceleration times for the four speed ramps available for ordinary operation, for the torque ramp and the speed/torque ramp in JOG mode.

Using two special parameters, you can also set the start rounding off and the end rounding off for the acceleration ramps, while two different parameters allow setting the start rounding off and the end rounding off for the deceleration ramps. A fifth parameter allows selecting the ramps for the preset rounding off.

#### 12.1.1. DESCRIPTION OF THE SPEED RAMPS

For the four speed ramps that can be selected through a combination of the digital inputs set in **C167** and **C168**, you can set the following: acceleration time, deceleration time and their units of measure, allowing increasing the programmable time range.

**P009** Ramp Up Time 1

**P010** Ramp Down Time 1

**P012** Ramp Up Time 2

**P013** Ramp Down Time 2

**P014** Unit of Measure for Ramp Times 1 and 2

**P015** Ramp Up Time 3

**P016** Ramp Down Time 3

**P018** Ramp Up Time 4

**P019** Ramp Down Time 4

**P020** Unit of Measure for Ramp Times 3 and 4

The set ramp time corresponds to the time the speed reference takes to reach the max. speed (from 0 rpm) as an absolute value between min. speed and max. speed of the selected motor (**C028** and **C029** for motor 1, and so on). The time unit of measure may have the following values:

0 → 0.01 s

1 → 0.1 s

2 → 1 s

3 → 10 s

The programmable range may be 0s – 327000s.

Example of a speed ramp:

**Table 22: Example of a Speed Ramp**

| P014  |        | Range P009 – P010 |          |
|-------|--------|-------------------|----------|
| Value | Coding | Min.              | Max.     |
| 0     | 0.01 s | 0                 | 327.00 s |
| 1     | 0.1 s  | 0                 | 3270.0 s |
| 2     | 1s     | 0                 | 32700 s  |
| 3     | 10 s   | 0                 | 327000 s |

The factory setting of the unit of measure is 0.1 s; the ramp time is 10 sec.

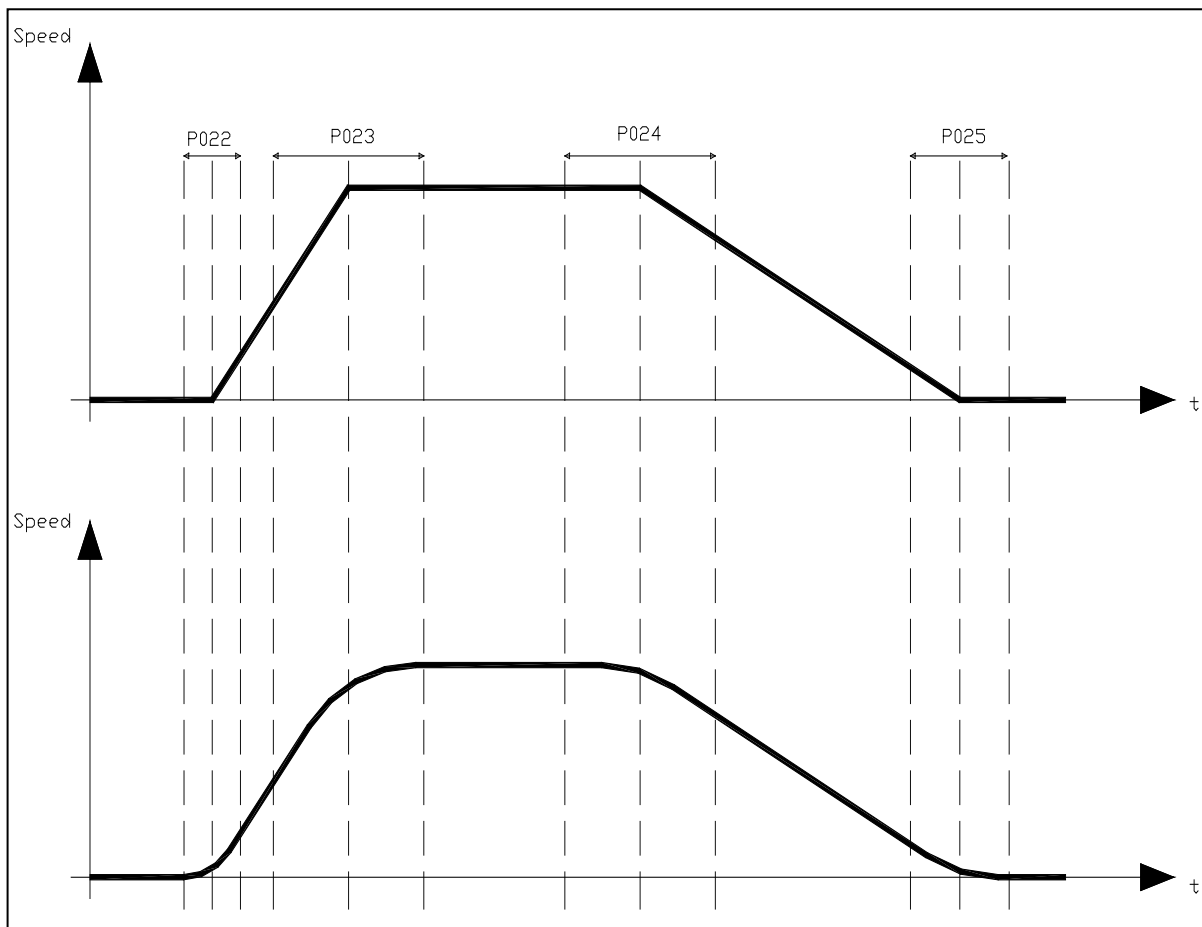

Figure 4: Example of S ramps

You can also select the rounding off and the rounding off percentage for the 4 stages of starting ramp up and the starting ramp down, and for the end ramp up and the end ramp down (S ramps). The ramp rounding off allows reaching the reference end value with a zero tangent, both while accelerating and while decelerating, thus suppressing torque peaks that could damage mechanical couplings.

The rounding off is expressed as a percentage of the ramp time it relates to; if used, it allows increasing the preset ramp time by half the sum value of the two rounding off values. Its effect is shown in the figures below.

Example: **P009** = 10sec ; **P021** = 1111 binary (rounding off selected for all four ramps); **P022** = 50%; **P023** = 50%

The resulting ramp up time is as follows:

$$P009 + (( P009 * (P022+P023)/2 )/100 ) = 10 + (( 10 * (50+50)/2 )/100 ) = 15 \text{ sec}$$

The effect of this rounding off can be seen in the figures below:

The figure shows two patterns for the ramp reference. The first pattern is not rounded off; the second pattern has the same ramp times, but different rounding off values are applied to the start/end ramp up/down time.

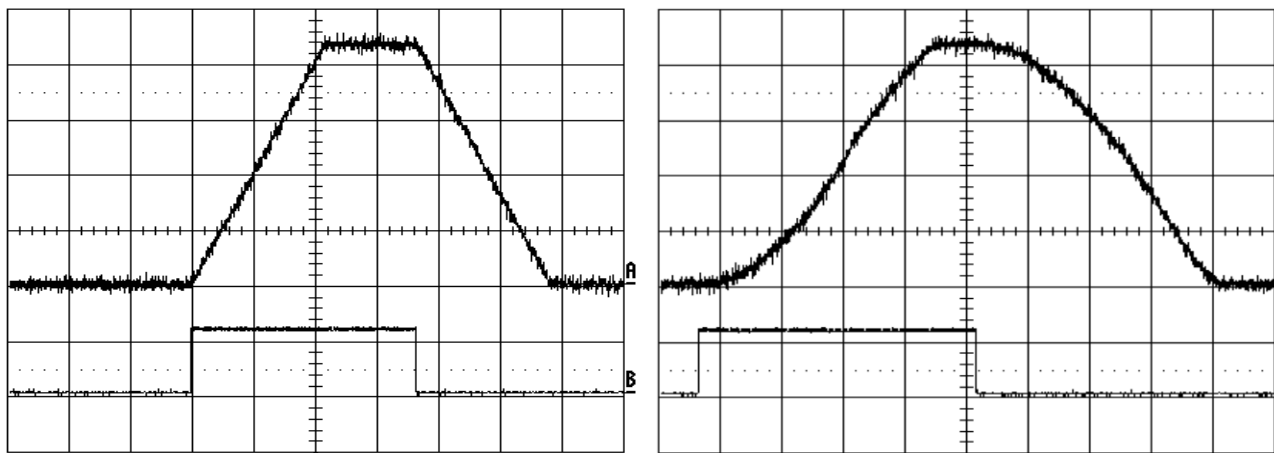

**Figure 5: Speed profile without Rounding Off and with Rounding Off 2 (example)**

In the figures above, the run command is represented by the high level of the second signal. Note that the time the reference takes to reach constant rpm depends not only on the ramp times, but also on the rounding off values you have defined.

### Acceleration RESET function

This parameter has effect only if S ramps are used. Parameter **P031** enables to reset acceleration when reference trends change.

Whenever a speed reference trend changes, the motor acceleration is instantly set to zero and the ramp output reference will be computed considering the preset rounding off (see

Figure 6). The figure shows the instant when deceleration begins; the rounding off value assigned to the speed reference when the gradient changes is the value set for the deceleration starting stage.

If parameter **P031** is set to [No], acceleration is brought to zero before the speed reference starts decreasing, then deceleration begins with the preset pattern.

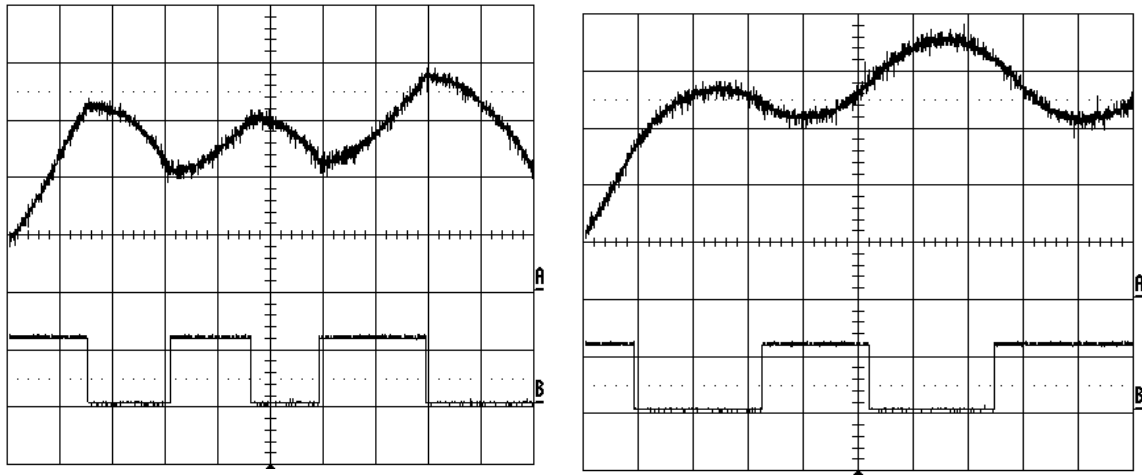

Figure 6: Speed profile with Acceleration Reset - Yes to No (Example)

## 12.1.2. DESCRIPTION OF THE TORQUE RAMPS

If the control algorithm is VTC or FOC and if it is controlled by setting “Torque” (**C011** for motor 1, **C054** for motor 2, and **C097** for motor 3 respectively), the reference is “ramped” based on the values set in parameter **P026** (torque increase ramp time), **P027** (torque decrease ramp time), and **P028** (unit of measure for the ramp times). The ramp up time setting is the time the output torque reference takes to go from 0 to the max. value (as an absolute value) between Torque min. and Torque max. of the selected motor (**C047**, **C048** for motor 1 and so on).

## 12.2. List of Parameters P009 to P033

Table 23: List of parameters P009 to P033

| Parameter | FUNCTION                                     | User Level  | Default Values            | MODBUS Address |
|-----------|--|-------------|---------------------------|----------------|
| P009      | Speed ramp 1: acceleration time              | BASIC       | See Table 80 and Table 84 | 609            |
| P010      | Speed ramp 1: deceleration time              | BASIC       | See Table 80 and Table 84 | 610            |
| P012      | Speed ramp 2: acceleration time              | ADVANCED    | See Table 80 and Table 84 | 612            |
| P013      | Speed ramp 2: deceleration time              | ADVANCED    | See Table 80 and Table 84 | 613            |
| P014      | Speed ramps 1 and 2: time unit of measure    | ADVANCED    | See Table 80 and Table 84 | 614            |
| P015      | Speed ramp 3: acceleration time              | ADVANCED    | See Table 80 and Table 84 | 615            |
| P016      | Speed ramp 3: deceleration time              | ADVANCED    | See Table 80 and Table 84 | 616            |
| P018      | Speed ramp 4: acceleration time              | ADVANCED    | See Table 80 and Table 84 | 618            |
| P019      | Speed ramp 4: deceleration time              | ADVANCED    | See Table 80 and Table 84 | 619            |
| P020      | Speed ramps 3 and 4: time unit of measure    | ADVANCED    | See Table 80 and Table 84 | 620            |
| P021      | Selection for S ramp rounding off            | ADVANCED    | 1 [On]                    | 621            |
| P022      | Acceleration S ramp: start rounding off time | ADVANCED    | See Table 80 and Table 84 | 622            |
| P023      | Acceleration S ramp: end rounding off time   | ADVANCED    | See Table 80 and Table 84 | 623            |
| P024      | Deceleration S ramp: start rounding off time | ADVANCED    | See Table 80 and Table 84 | 624            |
| P025      | Deceleration S ramp: end rounding off time   | ADVANCED    | See Table 80 and Table 84 | 625            |
| P026      | Torque ramp time: up                         | ADVANCED    | 5 s                       | 626            |
| P027      | Torque ramp time: down                       | ADVANCED    | 5 s                       | 627            |
| P028      | Unit of measure for torque ramp time         | ADVANCED    | 0.1 s                     | 628            |
| P029      | Jog ramp acceleration time                   | ADVANCED    | 1 s                       | 629            |
| P030      | Jog ramp deceleration time                   | ADVANCED    | 1 s                       | 629            |
| P031      | Gradient variation acceleration reset        | ADVANCED    | 1 : [YES]                 | 630            |
| P032      | Fire Mode Ramp: acceleration time            | ENGINEERING | See Table 80 and Table 84 | 632            |
| P033      | Fire Mode Ramp: deceleration time            | ENGINEERING | See Table 80 and Table 84 | 633            |

**P009 Speed Ramp 1: Acceleration Time**

|             |                 |  |   |
|-------------|-----------------|--|---|
| <b>P009</b> | <b>Range</b>    | 0 ÷ 32700  | 0 ÷ 327.00 s if <b>P014</b> =0 → 0.01 s<br>0 ÷ 3270.0 s if <b>P014</b> =1 → 0.1 s<br>0 ÷ 32700 s if <b>P014</b> =2 → 1 s<br>0 ÷ 327000 s if <b>P014</b> =3 → 10 s |
|             | <b>Default</b>  | See Table 80 and Table 84  |   |
|             | <b>Level</b>    | BASIC  |   |
|             | <b>Address</b>  | 609  |   |
|             | <b>Function</b> | Determines the time the reference takes to go from 0 rpm to the max. preset speed (considering the max. value between absolute values for max. speed and min. speed set for the selected motor).<br>If S ramps are used, the actual time the reference takes to reach constant rpm exceeds the time set in <b>P009</b> for a percentage equal to $(P022+P023)/2$ . |   |

**P010 Speed Ramp 1: Deceleration Time**

|             |                 |  |   |
|-------------|-----------------|--|---|
| <b>P010</b> | <b>Range</b>    | 0 ÷ 32700  | 0 ÷ 327.00 s if <b>P014</b> =0 → 0.01 s<br>0 ÷ 3270.0 s if <b>P014</b> =0 → 0.1 s<br>0 ÷ 32700 s if <b>P014</b> =0 → 1 s<br>0 ÷ 327000 s if <b>P014</b> =0 → 10 s |
|             | <b>Default</b>  | See Table 80 and Table 84  |   |
|             | <b>Level</b>    | BASIC  |   |
|             | <b>Address</b>  | 610  |   |
|             | <b>Function</b> | Determines the time the reference takes to go from the max. preset speed (considering the max. value between absolute values for max. speed and min. speed set for the selected motor) to zero rpm.<br>If S ramps are used, the actual time the reference takes to reach 0 speed exceeds the time set in <b>P010</b> for a percentage equal to $(P024+P025)/2$ . |   |

**P012 Speed Ramp 2: Acceleration Time**

|             |                 |                                    |   |
|-------------|-----------------|------------------------------------|---|
| <b>P012</b> | <b>Range</b>    | 0 ÷ 32700                          | 0 ÷ 327.00 s if <b>P014</b> =0 → 0.01 s<br>0 ÷ 3270.0 s if <b>P014</b> =0 → 0.1 s<br>0 ÷ 32700 s if <b>P014</b> =0 → 1 s<br>0 ÷ 327000 s if <b>P014</b> =0 → 10 s |
|             | <b>Default</b>  | See Table 80 and Table 84          |   |
|             | <b>Level</b>    | ADVANCED                           |   |
|             | <b>Address</b>  | 612                                |   |
|             | <b>Function</b> | Same as ramp 1 (see <b>P009</b> ). |   |



**NOTE**

Values for ramp 2 can be applied to the reference provided that multiramp digital inputs are set up and that ramp 2 is selected (see the DIGITAL INPUTS MENU).

**P013 Speed Ramp 2: Deceleration Time**

|             |                 |                                    |   |
|-------------|-----------------|------------------------------------|---|
| <b>P013</b> | <b>Range</b>    | 0 ÷ 32700                          | 0 ÷ 327.00 s if <b>P014</b> =0 → 0.01 s<br>0 ÷ 3270.0 s if <b>P014</b> =0 → 0.1 s<br>0 ÷ 32700 s if <b>P014</b> =0 → 1 s<br>0 ÷ 327000 s if <b>P014</b> =0 → 10 s |
|             | <b>Default</b>  | See Table 80 and Table 84          |   |
|             | <b>Level</b>    | ADVANCED                           |   |
|             | <b>Address</b>  | 613                                |   |
|             | <b>Function</b> | Same as ramp 1 (see <b>P010</b> ). |   |



**NOTE**

Values for ramp 2 can be applied to the reference provided that multiramp digital inputs are set up and that ramp 2 is selected (see the DIGITAL INPUTS MENU).

**P014 Speed Ramps 1 and 2: Time Unit of Measure**

|             |                 |  |  |
|-------------|-----------------|--|--|
| <b>P014</b> | <b>Range</b>    | 0 ÷ 3  | 0 → 0.01 s<br>1 → 0.1 s<br>2 → 1 s<br>3 → 10 s |
|             | <b>Default</b>  | See Table 80 and Table 84  |  |
|             | <b>Level</b>    | ADVANCED   |  |
|             | <b>Address</b>  | 614  |  |
|             | <b>Function</b> | Defines the unit of measure for the time periods for speed ramp 1 ( <b>P009</b> and <b>P010</b> ), for speed ramp 2 ( <b>P012</b> and <b>P013</b> ), and for ramps in Fire Mode ( <b>P032</b> and <b>P033</b> ). The allowable programmable range may be extended from 0 s to 327000s.<br>E.g.<br><b>P014</b> =1 then <b>P009</b> =100; this means <b>P009</b> = 100 x 0.1 s = 10 s<br><b>P014</b> =0 then <b>P009</b> =100; this means <b>P009</b> = 100 x 0.01 s = 1 s<br><b>P014</b> =3 then <b>P009</b> =100; this means <b>P009</b> = 100 x 10 s = 1000 s |  |

**P015 Speed Ramp 3: Acceleration Time**

|             |                 |                                    |   |
|-------------|-----------------|------------------------------------|---|
| <b>P015</b> | <b>Range</b>    | 0 ÷ 32700                          | 0 ÷ 327.00 s if <b>P020</b> =0 → 0.01 s<br>0 ÷ 3270.0 s if <b>P020</b> =0 → 0.1 s<br>0 ÷ 32700 s if <b>P020</b> =0 → 1 s<br>0 ÷ 327000 s if <b>P020</b> =0 → 10 s |
|             | <b>Default</b>  | See Table 80 and Table 84          |   |
|             | <b>Level</b>    | ADVANCED                           |   |
|             | <b>Address</b>  | 615                                |   |
|             | <b>Function</b> | Same as ramp 1 (see <b>P009</b> ). |   |



**NOTE**

Values for ramp 3 can be applied to the reference provided that multiramp digital inputs are set up and that ramp 3 is selected (see the DIGITAL INPUTS MENU).

**P016 Speed Ramp 3: Deceleration Time**

|             |                 |                                    |   |
|-------------|-----------------|------------------------------------|---|
| <b>P016</b> | <b>Range</b>    | 0 ÷ 32700                          | 0 ÷ 327.00 s if <b>P020</b> =0 → 0.01 s<br>0 ÷ 3270.0 s if <b>P020</b> =0 → 0.1 s<br>0 ÷ 32700 s if <b>P020</b> =0 → 1 s<br>0 ÷ 327000 s if <b>P020</b> =0 → 10 s |
|             | <b>Default</b>  | See Table 80 and Table 84          |   |
|             | <b>Level</b>    | ADVANCED                           |   |
|             | <b>Address</b>  | 616                                |   |
|             | <b>Function</b> | Same as ramp 1 (see <b>P010</b> ). |   |



**NOTE** Values for ramp 3 can be applied to the reference provided that multiramp digital inputs are set up and that ramp 3 is selected (see the DIGITAL INPUTS MENU).

**P018 Speed Ramp 4: Acceleration Time**

|             |                 |                                    |   |
|-------------|-----------------|------------------------------------|---|
| <b>P018</b> | <b>Range</b>    | 0 ÷ 32700                          | 0 ÷ 327.00 s if <b>P020</b> =0 → 0.01 s<br>0 ÷ 3270.0 s if <b>P020</b> =0 → 0.1 s<br>0 ÷ 32700 s if <b>P020</b> =0 → 1 s<br>0 ÷ 327000 s if <b>P020</b> =0 → 10 s |
|             | <b>Default</b>  | See Table 80 and Table 84          |   |
|             | <b>Level</b>    | ADVANCED                           |   |
|             | <b>Address</b>  | 618                                |   |
|             | <b>Function</b> | Same as ramp 1 (see <b>P009</b> ). |   |



**NOTE** Values for ramp 4 can be applied to the reference provided that multiramp digital inputs are set up and that ramp 4 is selected (see the DIGITAL INPUTS MENU).

**P019 Speed Ramp 4: Deceleration Time**

|             |                 |                                    |   |
|-------------|-----------------|------------------------------------|---|
| <b>P019</b> | <b>Range</b>    | 0 ÷ 32700                          | 0 ÷ 327.00 s if <b>P020</b> =0 → 0.01 s<br>0 ÷ 3270.0 s if <b>P020</b> =0 → 0.1 s<br>0 ÷ 32700 s if <b>P020</b> =0 → 1 s<br>0 ÷ 327000 s if <b>P020</b> =0 → 10 s |
|             | <b>Default</b>  | See Table 80 and Table 84          |   |
|             | <b>Level</b>    | ADVANCED                           |   |
|             | <b>Address</b>  | 619                                |   |
|             | <b>Function</b> | Same as ramp 1 (see <b>P010</b> ). |   |



**NOTE** Values for ramp 4 can be applied to the reference provided that multiramp digital inputs are set up and that ramp 4 is selected (see the DIGITAL INPUTS MENU).

**P020 Speed Ramps 3 and 4: Time Unit of Measure**

|             |                 |   |  |
|-------------|-----------------|---|--|
| <b>P020</b> | <b>Range</b>    | 0 ÷ 3   | 0 → 0.01 s<br>1 → 0.1 s<br>2 → 1 s<br>3 → 10 s |
|             | <b>Default</b>  | See Table 80 and Table 84   |  |
|             | <b>Level</b>    | ADVANCED  |  |
|             | <b>Address</b>  | 620   |  |
|             | <b>Function</b> | Defines the unit of measure for the times for speed ramp 3, <b>P015</b> and <b>P016</b> , and speed ramp 4, <b>P020</b> and <b>P018</b> . The allowable programmable range may be extended from 0 s to 327000s. |  |

**P021 Selection for Ramp Rounding Off**

|             |                 |  |   |
|-------------|-----------------|--|---|
| <b>P021</b> | <b>Range</b>    | 0000b ÷ 1111b binary<br>0x0000 ÷ 0x000F hexadecimal<br>0 ÷ 15  | 0000b (no S ramps)<br>1111b (all S ramps) |
|             | <b>Default</b>  | 1111b (all S ramps)  |   |
|             | <b>Level</b>    | ADVANCED   |   |
|             | <b>Address</b>  | 621  |   |
|             | <b>Function</b> | In this parameter, you can select the bit corresponding to the ramp to be rounded off.<br>Example:<br><b>P021</b> = 0011b = 3 decimal → ramps 1 and 2 are rounded off.<br>The ramp rounding off allows reaching the reference end value with a zero tangent, both while accelerating and while decelerating, thus suppressing torque peaks that could damage mechanical couplings. |   |

**P022 Acceleration Ramp: Start Rounding Off Time**

|             |                 |  |           |
|-------------|-----------------|--|-----------|
| <b>P022</b> | <b>Range</b>    | 0 ÷ 100  | 0 ÷ 100 % |
|             | <b>Default</b>  | See Table 80 and Table 84  |           |
|             | <b>Level</b>    | ADVANCED   |           |
|             | <b>Address</b>  | 622  |           |
|             | <b>Function</b> | Sets the rounding off time period for the first stage of the acceleration ramp. This parameter is expressed as a percentage of the acceleration ramp time of the active ramp.<br>Example: the second ramp is active with an acceleration ramp time of 5 secs, <b>P022</b> = 50%. Therefore, reference acceleration is limited for the first 2.5 secs of the ramp time. |           |



**NOTE** When using parameter **P022**, the preset acceleration ramp time is increased by:  $(P022\%)/2$ .

**P023 Acceleration Ramp: End Rounding Off Time**

|             |                 |   |           |
|-------------|-----------------|---|-----------|
| <b>P023</b> | <b>Range</b>    | 0 ÷ 100   | 0 ÷ 100 % |
|             | <b>Default</b>  | See Table 80 and Table 84   |           |
|             | <b>Level</b>    | ADVANCED  |           |
|             | <b>Address</b>  | 623   |           |
|             | <b>Function</b> | Sets the rounding off time period for the end stage of the acceleration ramp. This parameter is expressed as a percentage of the acceleration ramp time of the active ramp. |           |



**NOTE** When using parameter **P023**, the preset acceleration ramp time is increased by:  $(P023\%)/2$ .

**P024 Deceleration Ramp: Start Rounding Off Time**

|             |                 |   |           |
|-------------|-----------------|---|-----------|
| <b>P024</b> | <b>Range</b>    | 0 ÷ 100   | 0 ÷ 100 % |
|             | <b>Default</b>  | See Table 80 and Table 84   |           |
|             | <b>Level</b>    | ADVANCED  |           |
|             | <b>Address</b>  | 624   |           |
|             | <b>Function</b> | See the function for <b>P022</b> . The only difference is that this rounding off function is applied to the first stage of a deceleration ramp. |           |



**NOTE** When using parameter **P024**, the preset deceleration ramp time is increased by:  $(P024\%)/2$ .

**P025 Deceleration Ramp: End Rounding Off Time**

|             |                 |  |           |
|-------------|-----------------|--|-----------|
| <b>P025</b> | <b>Range</b>    | 0 ÷ 100  | 0 ÷ 100 % |
|             | <b>Default</b>  | See Table 80 and Table 84  |           |
|             | <b>Level</b>    | ADVANCED   |           |
|             | <b>Address</b>  | 625  |           |
|             | <b>Function</b> | See the function for <b>P023</b> . The only difference is that this rounding off function is applied to the last stage of a deceleration ramp. |           |



**NOTE** When using parameter **P025**, the preset deceleration ramp time is increased by:  $(P025\%)/2$ .

**P026 Torque Ramp Time: Up**

|             |                 |   |                         |
|-------------|-----------------|---|-------------------------|
| <b>P026</b> | <b>Range</b>    | 0 ÷ 32700   | <b>Function of P028</b> |
|             | <b>Default</b>  | 500   | 50 sec                  |
|             | <b>Level</b>    | ADVANCED  |                         |
|             | <b>Address</b>  | 626   |                         |
|             | <b>Function</b> | Defines the time taken by the torque reference of the selected motor to go to zero from max. value (as an absolute value between Torque min. and Torque max.); ( <b>C047–C048</b> for motor 1 and so on). |                         |

**P027 Torque Ramp Time: Down**

|             |                 |   |                         |
|-------------|-----------------|---|-------------------------|
| <b>P027</b> | <b>Range</b>    | 0 ÷ 32700   | <b>Function of P028</b> |
|             | <b>Default</b>  | 500   | 50 sec                  |
|             | <b>Level</b>    | ADVANCED  |                         |
|             | <b>Address</b>  | 627   |                         |
|             | <b>Function</b> | Defines the time taken by the torque reference of the selected motor to go from max. value to zero (as an absolute value between Torque min. and Torque max.); ( <b>C047–C048</b> for motor 1 and so on). |                         |

**P028 Unit of Measure for Torque Ramp Time**

|             |                 |  |  |
|-------------|-----------------|--|--|
| <b>P028</b> | <b>Range</b>    | 0 ÷ 3  | 0 → 0.01 s<br>1 → 0.1 s<br>2 → 1 s<br>3 → 10 s |
|             | <b>Default</b>  | 1  | 1 → 0.1 s                                      |
|             | <b>Level</b>    | ADVANCED   |  |
|             | <b>Address</b>  | 628  |  |
|             | <b>Function</b> | Defines the unit of measure for the torque ramp times. See the unit of measure for ramp 1 (par. <b>P014</b> ). |  |

**P029 Jog Ramp Acceleration Time**

|             |                 |  |              |
|-------------|-----------------|--|--------------|
| <b>P029</b> | <b>Range</b>    | 0 ÷ 6500   | 0 ÷ 6500 sec |
|             | <b>Default</b>  | 1  | 1sec         |
|             | <b>Level</b>    | ADVANCED   |              |
|             | <b>Address</b>  | 629  |              |
|             | <b>Function</b> | The preset time corresponds to the time the “ramped” speed/torque reference takes to go from zero to the JOG speed/torque value ( <b>P070</b> ). |              |

**P030 Jog Ramp Deceleration Time**

|             |                 |  |              |
|-------------|-----------------|--|--------------|
| <b>P030</b> | <b>Range</b>    | 0 ÷ 6500   | 0 ÷ 6500 sec |
|             | <b>Default</b>  | 1  | 1sec         |
|             | <b>Level</b>    | ADVANCED   |              |
|             | <b>Address</b>  | 630  |              |
|             | <b>Function</b> | The preset time corresponds to the time the “ramped” speed/torque reference takes to go from the JOG speed/torque value ( <b>P070</b> ) to zero. |              |

**P031 Gradient Variation Acceleration Reset**

|             |                 |   |                    |
|-------------|-----------------|---|--------------------|
| <b>P031</b> | <b>Range</b>    | 0 ÷ 1   | 0: [No] ; 1: [Yes] |
|             | <b>Default</b>  | 1   | 1: [Yes]           |
|             | <b>Level</b>    | ADVANCED  |                    |
|             | <b>Address</b>  | 631   |                    |
|             | <b>Function</b> | Defines whether acceleration is reset or not when switching from acceleration to deceleration and vice versa (reference gradient). For more details, see the description of the speed ramps at the beginning of this section. |                    |



**NOTE** Parameter **P031** is interlocked with parameter **C210** (Automatic extension of down ramp) so that **P031 = 0:No** cannot be programmed in conjunction with **C210 ≠ [With resistor]**.

**P032 Fire Mode Acceleration Ramp**

|  |                 |  |           |   |
|--|-----------------|--|-----------|---|
|  | <b>P032</b>     | <b>Range</b>   | 0 ÷ 32700 | 0 ÷ 327.00 s if <b>P014</b> =0 → 0.01 s<br>0 ÷ 3270.0 s if <b>P014</b> =1 → 0.1 s<br>0 ÷ 32700 s if <b>P014</b> =2 → 1 s<br>0 ÷ 327000 s if <b>P014</b> =3 → 10 s |
|  | <b>Default</b>  | See Table 80 and Table 84                                    |           |   |
|  | <b>Level</b>    | ENGINEERING  |           |   |
|  | <b>Address</b>  | 632  |           |   |
|  | <b>Function</b> | This ramp is used to accelerate the motor when in Fire Mode. |           |   |

**P033 Fire Mode Deceleration Ramp**

|  |                 |  |           |   |
|--|-----------------|--|-----------|---|
|  | <b>P033</b>     | <b>Range</b>   | 0 ÷ 32700 | 0 ÷ 327.00 s if <b>P014</b> =0 → 0.01 s<br>0 ÷ 3270.0 s if <b>P014</b> =1 → 0.1 s<br>0 ÷ 32700 s if <b>P014</b> =2 → 1 s<br>0 ÷ 327000 s if <b>P014</b> =3 → 10 s |
|  | <b>Default</b>  | See Table 80 and Table 84                                    |           |   |
|  | <b>Level</b>    | ENGINEERING  |           |   |
|  | <b>Address</b>  | 633  |           |   |
|  | <b>Function</b> | This ramp is used to decelerate the motor when in Fire Mode. |           |   |

## 13. INPUTS FOR REFERENCES MENU

### 13.1. Processing Speed/Torque References

The “**main reference**” is the value, at constant rpm, for the controlled physical variable (speed or torque) (M000, M007) “required” for the drive.

This reference is acquired by the drive only if the **START** command is active and the drive is **RUNNING**, otherwise it is ignored.

The **main reference** is the reference at constant rpm: when the drive is **RUNNING**, it will increment the speed or torque **set-point** which will reach the main reference with a timed ramp (see the RAMPS MENU).

The drive operating mode is factory-set to **MASTER** with a speed reference. In **SLAVE** mode, a torque reference is used; this operating mode may be configured for **VTC** control (Vector Torque Control) and **FOC** control (Field Oriented Control) only.

The **control algorithm** and the **MASTER/SLAVE mode** can be set for each of the 3 programmable motors, depending on which motor is active at that moment (motor 1, motor 2 or motor 3).

To enable the **SLAVE** mode, set the following parameters to 1 or 2:

**C011** (motor 1)

**C054** (motor 2)

**C097** (motor 3)

The SLAVE mode may also be selected through a digital input (see the DIGITAL INPUTS MENU).

When the main reference is acquired by the drive (**RUNNING** on), it becomes the reference for the time ramps generating the current speed/torque set-point for the connected motor.

The setup of the main reference is based on a number of parameters included in several menus:

**Table 24: Parameters used for the Inputs for References Menu**

| Parameters              | Menu                                  | Contents   |
|-------------------------|---------------------------------------|--|
| <b>P050 ÷ P074</b>      | <b>References</b>                     | Scaling parameters for references sent from analog inputs REF, AIN1, AIN2.<br>Scaling parameters for references sent from encoder and frequency input.<br>Parameters for changes made using the UP and DOWN keys.<br>Parameter for JOG reference setting.<br>Parameter for drive disabling in case of reference at min. value. |
| <b>P390 ÷ P399</b>      | <b>References from optional board</b> | Scaling parameters for references sent from analog inputs XAIN4, XAIN5.  |
| <b>P080 ÷ P098</b>      | <b>Multispeed</b>                     | Parameters setting preset multispeed values to be selected through digital inputs.   |
| <b>P105 ÷ P108</b>      | <b>Prohibit Speed</b>                 | Parameters setting prohibit speed values.  |
| <b>P115 ÷ P121</b>      | <b>Reference Variation Percent</b>    | Parameters setting slowing down values percent to be selected through digital inputs.  |
| <b>C143 ÷ C146</b>      | <b>Control Method</b>                 | Parameters setting the reference source.   |
| <b>C011, C028, C029</b> | <b>Configuration of Motor 1</b>       | Parameter setting the Master (speed) mode or the Slave (torque) mode. Parameters setting the min. speed or the max. speed.   |
| <b>C054, C071, C072</b> | <b>Configuration of Motor 2</b>       |  |
| <b>C097, C114, C115</b> | <b>Configuration of Motor 3</b>       |  |
| <b>C047, C048</b>       | <b>Limit for Motor 1</b>              | Parameters setting the min. torque and the max. torque.  |
| <b>C090, C091</b>       | <b>Limit for Motor 2</b>              |  |
| <b>C133, C134</b>       | <b>Limit for Motor 3</b>              |  |

The following pages contain block diagrams illustrating speed reference processing (Figure 6) and torque reference processing (Figure 7). Menus and parameters used are also stated.

**Speed Reference computing**

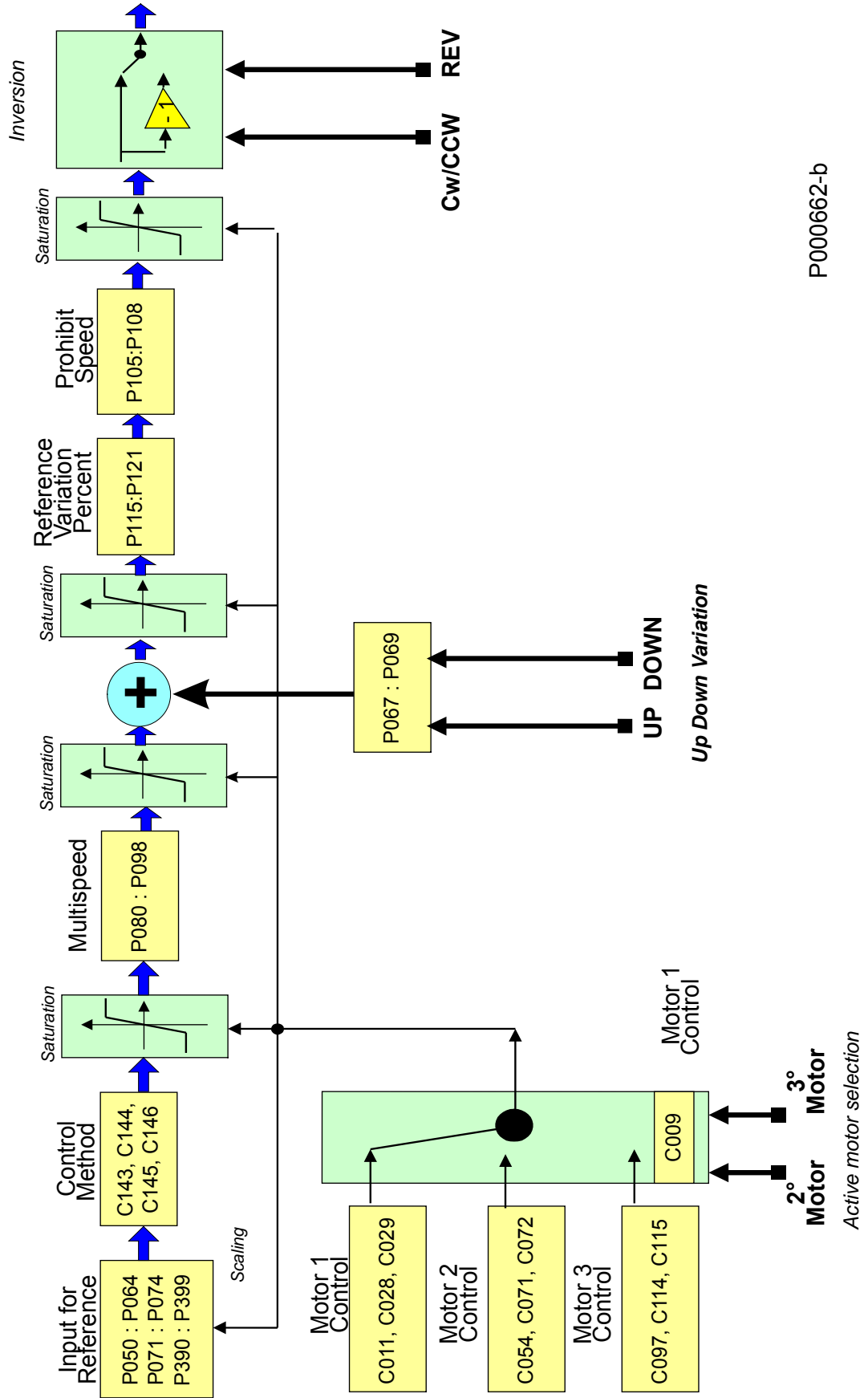

P000662-b

Figure 7: Speed Reference computing

# Torque Reference computing

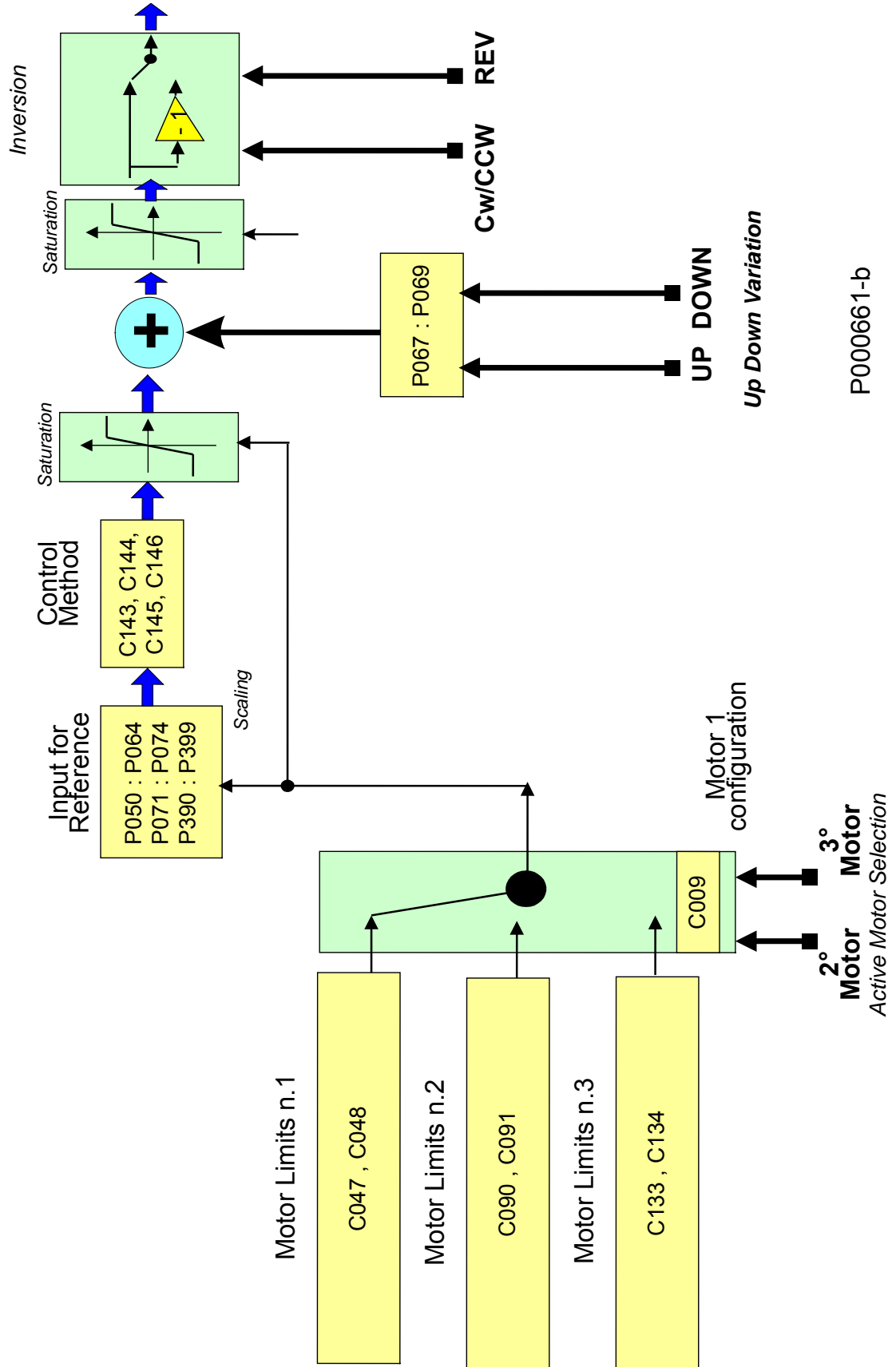

P000661-b

Figure 8: Torque Reference computing

### 13.2. Scaling Analog Inputs REF, AIN1, AIN2



**NOTE** Please refer to the Sinus Penta’s Installation Guide for hardware details about analog inputs.

Three analog inputs are available: REF, AIN1, AIN2.

They can be voltage inputs or current inputs (switching is made possible through hardware Dip-Switch **SW1** and software parameters) and are bipolar analog inputs (–10V ÷ +10V or –20mA ÷ +20mA).

**REF** input is single-ended; **AIN1** and **AIN2** inputs are differential inputs.

Factory setting is as follows: the **main speed reference** is given by **REF** analog input, **0V ÷ +10V** mode; only motor 1 is active. Its max. speed and min. speed parameters are **C088=1500** rpm and **C029=0** rpm respectively.

For the 3 analog inputs, parameters **P050 ÷ P064** allow setting the type of signal to be acquired, offset compensation (if any), scaling to obtain a speed reference or a torque reference, the signal filtering time constant.

Parameter **P053** sets the offset of the input analog signal (if **P053=0** offset is zero), while parameter **P054** defines the filtering time constant (factory setting: P054 = 5ms).

Type of input: for each analog input, Dip-Switch **SW1** allows setting the acquisition method of the input signal: voltage signal or current signal.

The voltage signal can be bipolar (–10V ÷ +10V) or unipolar (0V ÷ +10V).

The current signal can be bipolar (–20mA ÷ +20mA), unipolar (0mA ÷ +20mA) or can have a minimum offset (4mA ÷ 20mA).

The user will set each analog input mode in parameters **P050, P055, P060**.

**Table 25: Analog Input Hardware Mode**

| Type / Terminals         | Name | Type         | Dip-Switch             | Parameter   |
|--------------------------|------|--------------|------------------------|-------------|
| Single-ended input / 1,2 | REF  | ±10V Input   | SW1–1 off              | <b>P050</b> |
|                          |      | 0–20mA Input | SW1–1 on               |             |
| Differential input / 5,6 | AIN1 | ±10V Input   | SW1–2 off              | <b>P055</b> |
|                          |      | 0–20mA Input | SW1–2 on               |             |
| Differential input / 7,8 | AIN2 | ±10V Input   | SW1–3 off, SW1–4 5 off | <b>P060</b> |
|                          |      | 0–20mA Input | SW1–3 on, SW1–4 5 off  |             |
|                          |      | PTC Input    | SW1–3 off, SW1–4 5 on  | See note    |



**NOTE** If AIN2 input is configured as PTC, refer to the MOTOR THERMAL PROTECTION MENU to select the proper parameters. Its measures are no longer valid.



**NOTE** Configurations different from the ones stated in the table above are not allowed.



**CAUTION** For each analog input (REF, AIN1, AIN2), make sure that the “mode” parameter setting (**P050, P055, P060**) matches with the setting of the relevant SW1 Dip-Switches.

Scaling is obtained by setting the parameters relating to the **linear function for the conversion** from the value read by the analog input to the corresponding speed/torque reference value.

The **conversion function** is a **straight line** passing through **2 points** in **Cartesian coordinates** having the values read by the analog input in the X-axis, and the speed/torque reference values multiplied by the reference percentage parameters in the Y-axis.

**Each point** is detected through its **two coordinates**.

The ordinates of the two points are the following:

the value of **Speed\_Min** (or **Trq\_Min** for the torque reference) multiplied by the percentage set through **P051a/P056a/P061a/P071a/P073a** for the **first point**; the value of **Speed\_Max** (or **Trq\_Max** for the torque reference) multiplied by the percentage set through **P052a/P057a/P062a/P072a/P074a** for the **second point**.

**Speed\_Min** depends on the selected motor: see parameter **C028** (motor 1), **C071** (motor 2), or **C114** (motor 3).  
**Trq\_Min** depends on the selected motor: see parameter **C047** (motor 1), **C090** (motor 2) or **C133** (motor 3).

**Speed\_Max** depends on the selected motor: see parameter **C029** (motor 1), **C072** (motor 2) or **C115** (motor 3).  
**Trq\_Max** depends on the selected motor: see parameter **C048** (motor 1), **C091** (motor 2), or **C134** (motor 3).

The X-axis values of the two points depend on the analog input:

**REF Input:**

Parameter **P051** is the X-axis value of the **first point**; parameter **P052** is the X-axis value of the **second point**.

**AIN1 Input:**

Parameter **P056** is the X-axis value of the **first point**; parameter **P057** is the X-axis value of the **second point**.

**Input AIN2:**

Parameter **P061** is the X-axis value of the **first point**; parameter **P062** is the X-axis value of the **second point**.

The figure below illustrates how parameters set computing the signals for speed (or torque) analog reference.

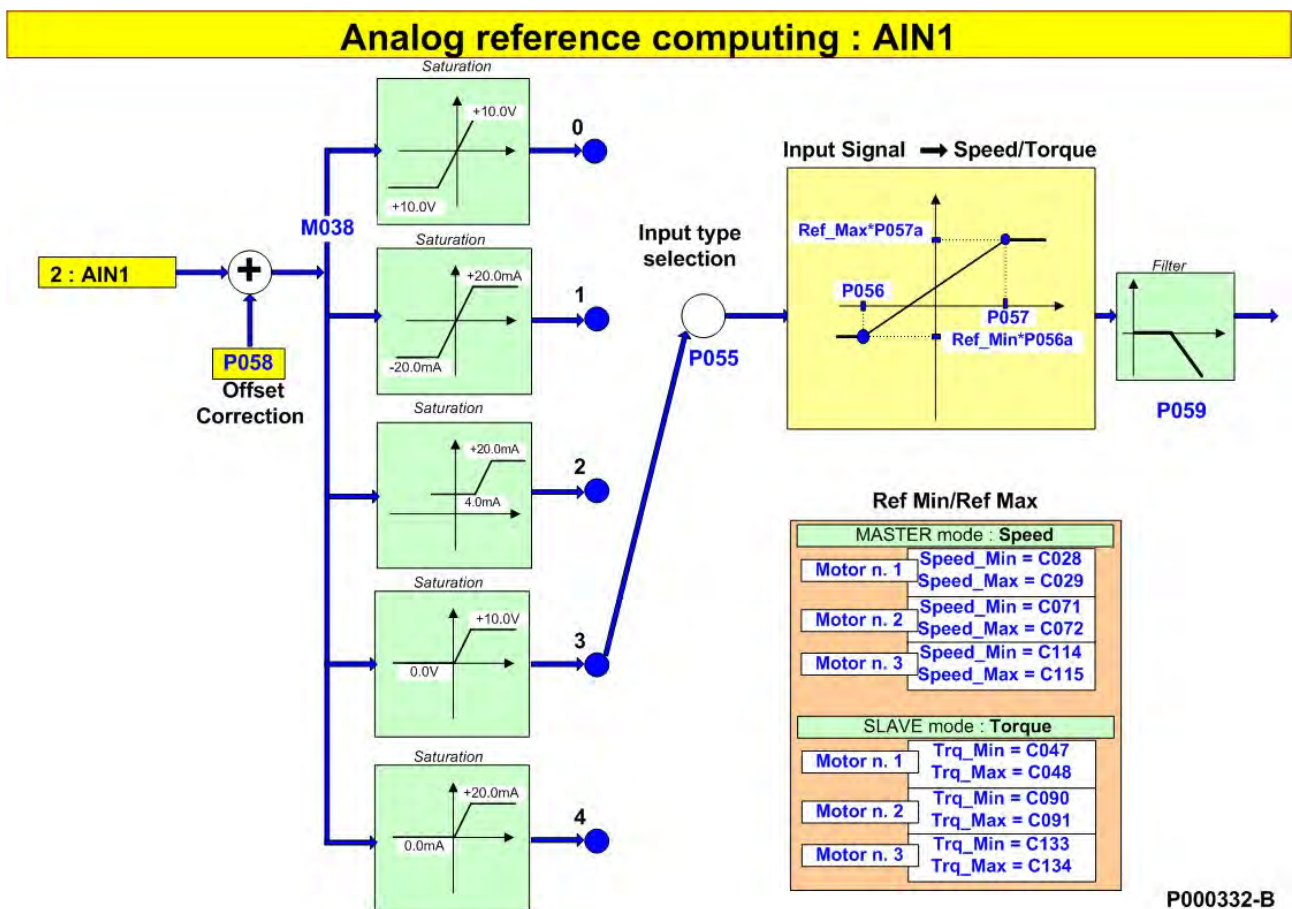

Figure 9: Computing Speed Analog Reference from terminal board: AIN1

The figures below illustrate programming examples for REF analog input, if motor 1 is selected and in MASTER mode: speed reference.

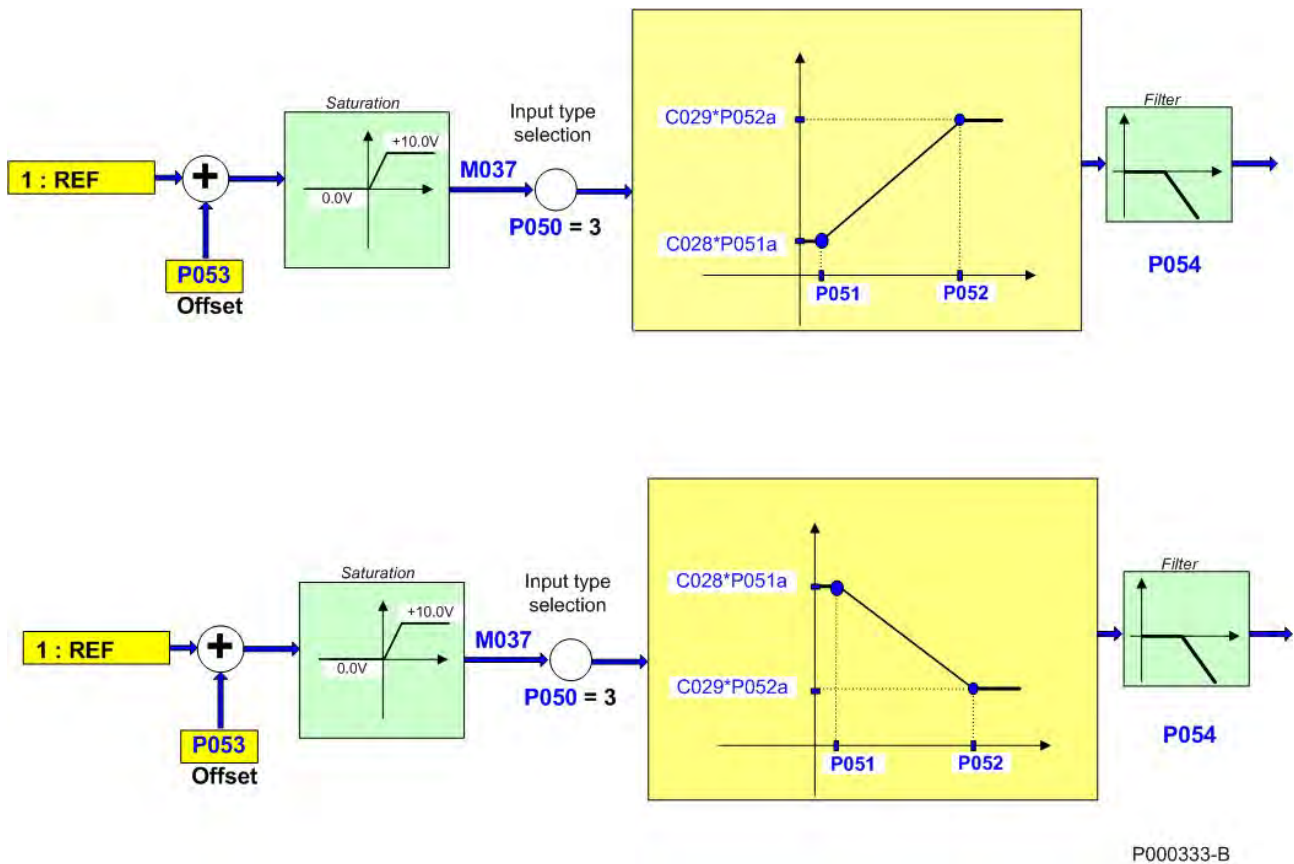

Figure 10: Computing Inputs REF (1) and (2) (examples)

The setup in the first part of the figure is as follows:

**P050 = 3**  
**P051 = 1V; P051a = 100%; P052 = 10V; P052a = 100%**  
**Speed\_Min = C028 = 100 rpm; Speed\_Max = C029 = 1100 rpm**

The setup in the second part of the figure is as follows:

**P050 = 3**  
**P051 = 1V; P051a = 100%; P052 = 10V; P052a = 100%**  
**Speed\_Min = C028 = 1200 rpm; Speed\_Max = C029 = 400 rpm**

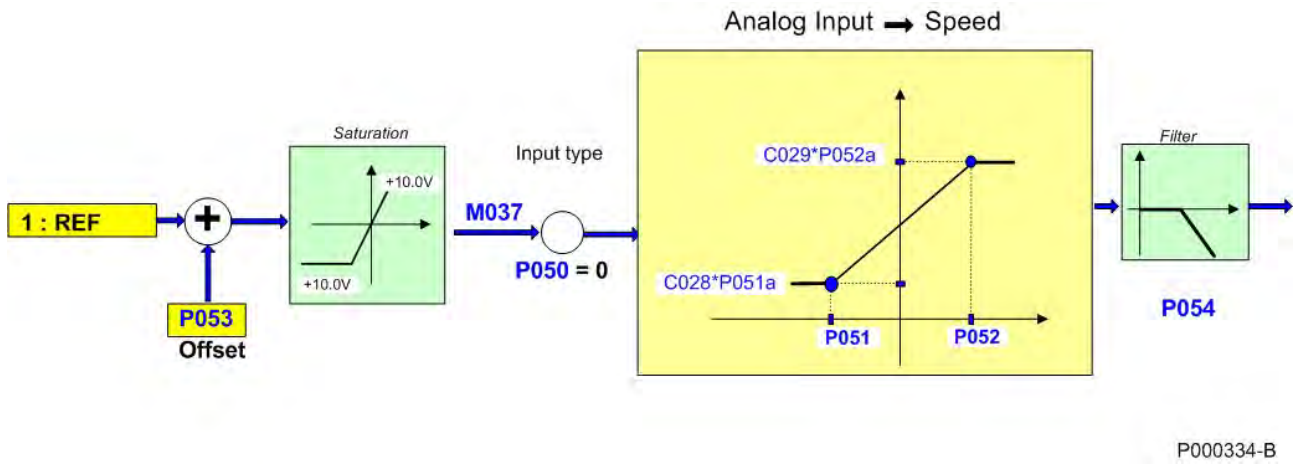

Figure 11: Computing REF Input (Example 3)

The Setup in Figure 11 is as follows:

**P050 = 0**

**P051 = -5V; P051a = 100%; P052 = +8V; P052a = 100%**

**Speed\_Min = C028 = 300 rpm; Speed\_Max = C029 = 1450 rpm**

### 13.3. List of Parameters P050 to P074a

Table 26: List of parameters P050 to P074a

| Parameter    | FUNCTION  | User Level | DEFAULT VALUE | MODBUS Address |
|--------------|---|------------|---------------|----------------|
| <b>P050</b>  | Type of signal over <b>REF</b> input  | ADVANCED   | 3: 0÷10V      | 650            |
| <b>P051</b>  | Value of <b>REF</b> input producing min. reference (X-axis)                               | ADVANCED   | 0.0V          | 651            |
| <b>P051a</b> | Percentage of Speed_Min/Trq_Min producing min. reference (Y-axis related to <b>P051</b> ) | ADVANCED   | 100.0%        | 675            |
| <b>P052</b>  | Value of <b>REF</b> input producing max. reference (X-axis)                               | ADVANCED   | 10.0V         | 652            |
| <b>P052a</b> | Percentage of Speed_Max/Trq_Max producing max. reference (Y-axis related to <b>P052</b> ) | ADVANCED   | 100.0%        | 676            |
| <b>P053</b>  | Offset over <b>REF</b> input  | ADVANCED   | 0V            | 653            |
| <b>P054</b>  | Filtering time over <b>REF</b> input  | ADVANCED   | 5 ms          | 654            |
| <b>P055</b>  | Type of signal over <b>AIN1</b> input   | ADVANCED   | 2: 4÷20mA     | 655            |
| <b>P056</b>  | Value of <b>AIN1</b> input producing min. reference (X-axis)                              | ADVANCED   | 4.0mA         | 656            |
| <b>P056a</b> | Percentage of Speed_Min/Trq_Min producing min. reference (Y-axis related to <b>P056</b> ) | ADVANCED   | 100.0%        | 677            |
| <b>P057</b>  | Value of <b>AIN1</b> input producing max. reference (X-axis)                              | ADVANCED   | 20.0mA        | 657            |
| <b>P057a</b> | Percentage of Speed_Max/Trq_Max producing max. reference (Y-axis related to <b>P057</b> ) | ADVANCED   | 100.0%        | 678            |
| <b>P058</b>  | Offset over <b>AIN1</b> input   | ADVANCED   | 0mA           | 658            |
| <b>P059</b>  | Filtering time over <b>AIN1</b> input   | ADVANCED   | 5 ms          | 659            |
| <b>P060</b>  | Type of signal over <b>AIN2</b> input   | ADVANCED   | 2: 4÷20mA     | 660            |
| <b>P061</b>  | Value of <b>AIN2</b> input producing min. reference (X-axis)                              | ADVANCED   | 4.0mA         | 661            |
| <b>P061a</b> | Percentage of Speed_Min/Trq_Min producing min. reference (Y-axis related to <b>P061</b> ) | ADVANCED   | 100.0%        | 679            |
| <b>P062</b>  | Value of <b>AIN2</b> input producing max. reference (X-axis)                              | ADVANCED   | 20.0mA        | 662            |
| <b>P062a</b> | Percentage of Speed_Max/Trq_Max producing max. reference (Y-axis related to <b>P062</b> ) | ADVANCED   | 100.0%        | 701            |
| <b>P063</b>  | Offset over <b>AIN2</b> input   | ADVANCED   | 0mA           | 663            |
| <b>P064</b>  | Filtering time over <b>AIN2</b> input   | ADVANCED   | 5 ms          | 664            |
| <b>P065</b>  | Minimum reference and <b>START</b> disabling threshold                                    | ADVANCED   | 0             | 665            |
| <b>P066</b>  | <b>START</b> disable delay at <b>P065</b> threshold                                       | ADVANCED   | 0s            | 666            |
| <b>P067</b>  | Keypad and terminal board UP/DOWN ramp  | ADVANCED   | Quadratic     | 667            |
| <b>P068</b>  | Storage of UP/DOWN values at Power Off  | ADVANCED   | YES           | 668            |
| <b>P068a</b> | Reset UP/DOWN speed/torque at Stop  | ADVANCED   | 0:[NO]        | 940            |
| <b>P068b</b> | Reset UP/DOWN PID at Stop   | ADVANCED   | 0:[NO]        | 941            |
| <b>P068c</b> | Reset UP/DOWN speed/torque at Source Changeover   | ADVANCED   | 0:[NO]        | 942            |
| <b>P068d</b> | Reset UP/DOWN PID at Source Changeover  | ADVANCED   | 0:[NO]        | 943            |
| <b>P069</b>  | Range of UP/DOWN reference  | ADVANCED   | 1: Unipolar   | 669            |
| <b>P070</b>  | Jog reference (speed/torque)  | ADVANCED   | 0%            | 670            |
| <b>P071</b>  | Value of <b>FIN</b> producing min. reference (X-axis)                                     | ADVANCED   | 10 kHz        | 671            |
| <b>P071a</b> | Percentage of Speed_Min/Trq_Min producing min. reference (Y-axis related to <b>P071</b> ) | ADVANCED   | 100.0%        | 713            |
| <b>P072</b>  | Value of <b>FIN</b> producing max. reference (X-axis)                                     | ADVANCED   | 100 kHz       | 672            |
| <b>P072a</b> | Percentage of Speed_Max/Trq_Max producing max. reference (Y-axis related to <b>P072</b> ) | ADVANCED   | 100.0%        | 714            |
| <b>P073</b>  | Value of <b>ECH</b> producing min. reference (X-axis)                                     | ADVANCED   | 0 rpm         | 673            |
| <b>P073a</b> | Percentage of Speed_Min/Trq_Min producing min. reference (Y-axis related to <b>P073</b> ) | ADVANCED   | 100.0%        | 702            |
| <b>P074</b>  | Value of <b>ECH</b> producing max. reference (X-axis)                                     | ADVANCED   | +1500 rpm     | 674            |
| <b>P074a</b> | Percentage of Speed_Max/Trq_Max producing max. reference (Y-axis related to <b>P074</b> ) | ADVANCED   | 100.0%        | 703            |

**P050 Type of Signal over REF Input**

|             |                 |  |  |
|-------------|-----------------|--|--|
| <b>P050</b> | <b>Range</b>    | 0 ÷ 4  | 0: ± 10 V<br>1: ± 20 mA<br>2: 4 ÷ 20 mA<br>3: 0 ÷ 10 V<br>4: 0 ÷ 20 mA |
|             | <b>Default</b>  | 3  | 3: 0 ÷ 10 V  |
|             | <b>Level</b>    | ADVANCED   |  |
|             | <b>Address</b>  | 650  |  |
|             | <b>Function</b> | <p>This parameter selects the type of single-ended, analog signal over the REF terminal in the terminal board. The signal can be a voltage signal, a current signal, a unipolar signal, or a bipolar signal.</p> <p><b>0:</b> ± 10 V Bipolar voltage input between -10V and +10V. The detected signal is saturated between these two values.</p> <p><b>1:</b> ± 20 mA Bipolar current input between -20mA and +20mA. The detected signal is saturated between these two values.</p> <p><b>2:</b> 4 ÷ 20 mA Unipolar current input with min. threshold, between +4 mA and +20mA. The detected signal is saturated between these two values. Before being saturated, if the detected signal is lower than 4 mA or greater than 20 mA, alarms <b>A066</b> or <b>A102</b> trip.</p> <p><b>3:</b> 0 ÷ 10 V Unipolar voltage input between 0V and +10V. The detected signal is saturated between these two values.</p> <p><b>4:</b> 0 ÷ 20 mA Unipolar current input between +0 mA and +20mA. The detected signal is saturated between these two values.</p> |  |



**NOTE**

The value set in parameter **P050** must match with the status of **SW1-1** switch allowing selecting the proper electric circuit for the analog signal processing (voltage signal or current signal).

**P051 Value of REF Input Producing Min. Reference (X-axis)**

|             |                 |   |  |
|-------------|-----------------|---|--|
| <b>P051</b> | <b>Range</b>    | -100 ÷ 100, if <b>P050</b> = 0<br>-200 ÷ 200, if <b>P050</b> = 1<br>+40 ÷ 200, if <b>P050</b> = 2<br>0 ÷ 100, if <b>P050</b> = 3<br>0 ÷ 200, if <b>P050</b> = 4   | -10.0 V ÷ 10.0 V, if <b>P050</b> = 0: ± 10 V<br>-20.0 mA ÷ 20.0 mA, if <b>P050</b> = 1: ± 20 mA<br>+4.0mA ÷ 20.0 mA, if <b>P050</b> = 2: 4 ÷ 20 mA<br>0.0 V ÷ 10.0V, if <b>P050</b> = 3: 0 ÷ 10 V<br>0.0 mA ÷ 20.0 mA, if <b>P050</b> = 4: 0 ÷ 20 mA |
|             | <b>Default</b>  | 0   | 0 V  |
|             | <b>Level</b>    | ADVANCED  |  |
|             | <b>Address</b>  | 651   |  |
|             | <b>Function</b> | <p>This parameter selects the value for REF input signal for minimum reference, or better the reference set in <b>C028xP051a</b> (Master mode) or in <b>C047xP051a</b> (Slave mode). If motor 2 is active, <b>C071</b> and <b>C090</b> will be used instead of <b>C028</b> and <b>C047</b>; if motor 3 is active, the values set in <b>C114</b> and <b>C133</b> will be used.</p> |  |

**P051a Percentage of Speed Min/Trq Min Producing Min. Reference (Y-axis related to P051)**

|              |                 |  |        |
|--------------|-----------------|--|--------|
| <b>P051a</b> | <b>Range</b>    | 0 ÷ 1000   | 100.0% |
|              | <b>Default</b>  | 1000   | 100.0% |
|              | <b>Level</b>    | ADVANCED   |        |
|              | <b>Address</b>  | 675  |        |
|              | <b>Function</b> | <p>This parameter represents the min. speed percentage (or the min. torque percentage for a torque reference) to be used for the minimum reference set with <b>P051</b>.</p> |        |

**P052 Value of REF Input Producing Max. Reference (X-axis)**

|             |                 |   |  |
|-------------|-----------------|---|--|
| <b>P052</b> | <b>Range</b>    | -100 ÷ 100, if <b>P050</b> = 0<br>-200 ÷ 200, if <b>P050</b> = 1<br>+40 ÷ 200, if <b>P050</b> = 2<br>0 ÷ 100, if <b>P050</b> = 3<br>0 ÷ 200, if <b>P050</b> = 4   | -10.0 V ÷ 10.0 V, if <b>P050</b> = 0; ± 10 V<br>-20.0 mA ÷ 20.0 mA, if <b>P050</b> = 1; ± 20 mA<br>+4.0mA ÷ 20.0 mA, if <b>P050</b> = 2; 4 ÷ 20 mA<br>0.0 V ÷ 10.0V, if <b>P050</b> = 3; 0 ÷ 10 V<br>0.0 mA ÷ 20.0 mA, if <b>P050</b> = 4; 0 ÷ 20 mA |
|             | <b>Default</b>  | 100   | 10.0 V   |
|             | <b>Level</b>    | ADVANCED  |  |
|             | <b>Address</b>  | 652   |  |
|             | <b>Function</b> | This parameter selects the value for REF input signal for maximum reference, or better the reference set in <b>C029xP052a</b> (Master mode) or in <b>C048xP052a</b> (Slave mode). If motor 2 is active, <b>C072</b> and <b>C091</b> will be used instead of <b>C029</b> and <b>C048</b> ; if motor 3 is active, the values set in <b>C115</b> and <b>C134</b> will be used. |  |

**P052a Percentage of Speed Max/Trq Max Producing Max. Reference (Y-axis related to P052)**

|              |                 |  |        |
|--------------|-----------------|--|--------|
| <b>P052a</b> | <b>Range</b>    | 0 ÷ 1000   | 100.0% |
|              | <b>Default</b>  | 1000   | 100.0% |
|              | <b>Level</b>    | ADVANCED   |        |
|              | <b>Address</b>  | 676  |        |
|              | <b>Function</b> | This parameter represents the max. speed percentage (or the max. torque percentage for a torque reference) to be used for the maximum reference set with <b>P052</b> . |        |

**P053 Offset over REF Input**

|             |                 |   |  |
|-------------|-----------------|---|--|
| <b>P053</b> | <b>Range</b>    | -2000 ÷ 2000  | -10.00 V ÷ +10.00 V, if <b>P050</b> = 0 or 3<br>- 20.00 mA ÷ +20.00 mA, if <b>P050</b> = 1,2,4 |
|             | <b>Default</b>  | 0   | 0 V  |
|             | <b>Level</b>    | ADVANCED  |  |
|             | <b>Address</b>  | 653   |  |
|             | <b>Function</b> | This parameter selects the offset correction value of the REF analog signal that has been measured.<br>The value set is added to the signal measured before saturation or conversion; its unit of measure is the same as the one of the signal selected for REF analog input. |  |

**P054 Filtering Time over REF Input**

|             |                 |  |              |
|-------------|-----------------|--|--------------|
| <b>P054</b> | <b>Range</b>    | 0 ÷ +65000   | 0 ÷ +65000ms |
|             | <b>Default</b>  | 5  | 5 ms         |
|             | <b>Level</b>    | ADVANCED   |              |
|             | <b>Address</b>  | 654  |              |
|             | <b>Function</b> | This parameter selects the value of the filter time constant of the first command applied to the REF input signal when the signal saturation and conversion is over. |              |

**P055 Type of Signal over AIN1 Input**

|             |                 |  |  |
|-------------|-----------------|--|--|
| <b>P055</b> | <b>Range</b>    | 0 ÷ 4  | 0: ± 10 V<br>1: ± 20 mA<br>2: 4 ÷ 20 mA<br>3: 0 ÷ 10 V<br>4: 0 ÷ 20 mA |
|             | <b>Default</b>  | 2  | 2: 4 ÷ 20 mA   |
|             | <b>Level</b>    | ADVANCED   |  |
|             | <b>Address</b>  | 655  |  |
|             | <b>Function</b> | <p>This parameter selects the type of differential analog signal over terminals <b>AIN1+</b> and <b>AIN1-</b> in the terminal board.</p> <p>The signal can be a voltage signal, a current signal, a unipolar signal, or a bipolar signal.</p> <p><b>0:</b> ± 10 V Bipolar voltage input between -10V and +10V. The detected signal is saturated between these two values.</p> <p><b>1:</b> ± 20 mA Bipolar current input between -20mA and +20mA. The detected signal is saturated between these two values.</p> <p><b>2:</b> 4 ÷ 20 mA Unipolar current input with min. threshold, between +4 mA and +20mA. The detected signal is saturated between these two values.</p> <p>Before being saturated, if the detected signal is lower than 4 mA or greater than 20 mA, alarms <b>A067</b> or <b>A103</b> trip.</p> <p><b>3:</b> 0 ÷ 10 V Unipolar voltage input between 0V and +10V. The detected signal is saturated between these two values.</p> <p><b>4:</b> 0 ÷ 20 mA Unipolar current input between +0 mA and +20mA. The detected signal is saturated between these two values.</p> |  |



**NOTE**

The value set in parameter **P055** must match with the status of switch **SW1-2** allowing selecting the proper electric circuit for the analog signal processing (voltage signal or current signal).

**P056 Value of AIN1 Input Producing Min. Reference (X-axis)**

|             |                 |  |  |
|-------------|-----------------|--|--|
| <b>P056</b> | <b>Range</b>    | -100 ÷ 100, if <b>P055</b> = 0<br>-200 ÷ 200, if <b>P055</b> = 1<br>+40 ÷ 200, if <b>P055</b> = 2<br>0 ÷ 100, if <b>P055</b> = 3<br>0 ÷ 200, if <b>P055</b> = 4  | -10.0 V ÷ 10.0 V, if <b>P055</b> = 0: ± 10 V<br>-20.0 mA ÷ 20.0 mA, if <b>P055</b> = 1: ± 20 mA<br>+4.0mA ÷ 20.0 mA, if <b>P055</b> = 2: 4 ÷ 20 mA<br>0.0 V ÷ 10.0V, if <b>P055</b> = 3: 0 ÷ 10 V<br>0.0 mA ÷ 20.0 mA, if <b>P055</b> = 4: 0 ÷ 20 mA |
|             | <b>Default</b>  | 40   | +4.0mA   |
|             | <b>Level</b>    | ADVANCED   |  |
|             | <b>Address</b>  | 656  |  |
|             | <b>Function</b> | <p>This parameter selects the value for AIN1 input signal for minimum reference, or better the reference set in <b>C028xP056a</b> (Master mode) or in <b>C047xP056a</b> (Slave mode). If motor 2 is active, <b>C071</b> and <b>C090</b> will be used instead of <b>C028</b> and <b>C047</b>; if motor 3 is active, the values set in <b>C114</b> and <b>C133</b> will be used.</p> |  |

**P056a Percentage of Speed Min/Trq Min Producing Min. Reference (Y-axis related to P056)**

|              |                 |  |        |
|--------------|-----------------|--|--------|
| <b>P056a</b> | <b>Range</b>    | 0 ÷ 1000   | 100.0% |
|              | <b>Default</b>  | 1000   | 100.0% |
|              | <b>Level</b>    | ADVANCED   |        |
|              | <b>Address</b>  | 677  |        |
|              | <b>Function</b> | <p>This parameter represents the min. speed percentage (or the min. torque percentage for a torque reference) to be used for the minimum reference set with <b>P056</b>.</p> |        |

**P057 Value of AIN1 Input Producing Max. Reference (X-axis)**

|             |                 |  |  |
|-------------|-----------------|--|--|
| <b>P057</b> | <b>Range</b>    | -100 ÷ 100, if <b>P055</b> = 0<br>-200 ÷ 200, if <b>P055</b> = 1<br>+40 ÷ 200, if <b>P055</b> = 2<br>0 ÷ 100, if <b>P055</b> = 3<br>0 ÷ 200, if <b>P055</b> = 4  | -10.0 V ÷ 10.0 V, if <b>P055</b> = 0: ± 10 V<br>-20.0 mA ÷ 20.0 mA, if <b>P055</b> = 1: ± 20 mA<br>+4.0mA ÷ 20.0 mA, if <b>P055</b> = 2: 4 ÷ 20 mA<br>0.0 V ÷ 10.0V, if <b>P055</b> = 3: 0 ÷ 10 V<br>0.0 mA ÷ 20.0 mA, if <b>P055</b> = 4: 0 ÷ 20 mA |
|             | <b>Default</b>  | 200  | +20.0mA  |
|             | <b>Level</b>    | ADVANCED   |  |
|             | <b>Address</b>  | 657  |  |
|             | <b>Function</b> | This parameter selects the value for AIN1 input signal for maximum reference, or better the reference set in <b>C029xP057a</b> (Master mode) or in <b>C048xP057a</b> (Slave mode). If motor 2 is active, <b>C072</b> and <b>C091</b> will be used instead of <b>C029</b> and <b>C048</b> ; if motor 3 is active, the values set in <b>C115</b> and <b>C134</b> will be used. |  |

**P057a Percentage of Speed Max/Trq Max Producing Max. Reference (Y-axis related to P057)**

|              |                 |  |        |
|--------------|-----------------|--|--------|
| <b>P057a</b> | <b>Range</b>    | 0 ÷ 1000   | 100.0% |
|              | <b>Default</b>  | 1000   | 100.0% |
|              | <b>Level</b>    | ADVANCED   |        |
|              | <b>Address</b>  | 678  |        |
|              | <b>Function</b> | This parameter represents the min. speed percentage (or the min. torque percentage for a torque reference) to be used for the minimum reference set with <b>P057</b> . |        |

**P058 Offset over AIN1 Input**

|             |                 |   |  |
|-------------|-----------------|---|--|
| <b>P058</b> | <b>Range</b>    | -2000 ÷ 2000  | -10.00 V ÷ +10.00 V, if <b>P055</b> = 0 or 3<br>- 20.00 mA ÷ +20.00 mA, if <b>P055</b> = 1,2,4 |
|             | <b>Default</b>  | 0   | 0 V  |
|             | <b>Level</b>    | ADVANCED  |  |
|             | <b>Address</b>  | 658   |  |
|             | <b>Function</b> | This parameter selects the offset correction value of AIN1 analog signal that has been measured.<br>The value set is added to the signal measured before saturation or conversion; its unit of measure is the same as the one of the signal selected for AIN1 analog input. |  |

**P059 Filtering Time over AIN1 Input**

|             |                 |   |              |
|-------------|-----------------|---|--------------|
| <b>P059</b> | <b>Range</b>    | 0 ÷ +65000  | 0 ÷ +65000ms |
|             | <b>Default</b>  | 5   | 5 ms         |
|             | <b>Level</b>    | ADVANCED  |              |
|             | <b>Address</b>  | 659   |              |
|             | <b>Function</b> | This parameter selects the value of the filter time constant of the first command applied to AIN1 input signal when the signal saturation and conversion is over. |              |

**P060 Type of Signal over AIN2 Input**

|             |                 |  |  |
|-------------|-----------------|--|--|
| <b>P060</b> | <b>Range</b>    | 0 ÷ 4  | 0: ± 10 V<br>1: ± 20 mA<br>2: 4 ÷ 20 mA<br>3: 0 ÷ 10 V<br>4: 0 ÷ 20 mA |
|             | <b>Default</b>  | 2  | 2: 4 ÷ 20 mA   |
|             | <b>Level</b>    | ADVANCED   |  |
|             | <b>Address</b>  | 660  |  |
|             | <b>Function</b> | <p>This parameter selects the type of differential analog signal over terminals <b>AIN2+</b> and <b>AIN2-</b> in the terminal board.<br/>The signal can be a voltage signal, a current signal, a unipolar signal, or a bipolar signal.</p> <p><b>0:</b> ± 10 V Bipolar voltage input between -10V and +10V. The detected signal is saturated between these two values.</p> <p><b>1:</b> ± 20 mA Bipolar current input between -20mA and +20mA. The detected signal is saturated between these two values.</p> <p><b>2:</b> 4 ÷ 20 mA Unipolar current input with min. threshold, between +4 mA and +20mA. The detected signal is saturated between these two values.<br/>Before being saturated, if the detected signal is lower than 4 mA or greater than 20 mA, alarms <b>A068</b> or <b>A104</b> trip.</p> <p><b>3:</b> 0 ÷ 10 V Unipolar voltage input between 0V and +10V. The detected signal is saturated between these two values.</p> <p><b>4:</b> 0 ÷ 20 mA Unipolar current input between +0 mA and +20mA. The detected signal is saturated between these two values.</p> |  |



**NOTE**

The value set in parameter **P060** must match with the status of switches **SW1-3**, **SW1-4** and **SW1-5** allowing selecting the proper electric circuit for the analog signal processing (voltage signal or current signal).



**NOTE**

If the PTC thermal protection (**C274**) is enabled, the reference from **AIN2** is automatically managed as a 0 ÷ 10V input. The only parameter enabled for the control of AIN2 is **P064**; **P060**, **P061**, **P061a**, **P062**, **P062a** and **P063** cannot be viewed and are not considered for calculations.

**P061 Value of AIN2 Input Producing Min. Reference (X-axis)**

|             |                 |  |  |
|-------------|-----------------|--|--|
| <b>P061</b> | <b>Range</b>    | -100 ÷ 100, if <b>P060</b> = 0<br>-200 ÷ 200, if <b>P060</b> = 1<br>+40 ÷ 200, if <b>P060</b> = 2<br>0 ÷ 100, if <b>P060</b> = 3<br>0 ÷ 200, if <b>P060</b> = 4  | -10.0 V ÷ 10.0 V, if <b>P060</b> = 0: ± 10 V<br>-20.0 mA ÷ 20.0 mA, if <b>P060</b> = 1: ± 20 mA<br>+4.0mA ÷ 20.0 mA, if <b>P060</b> = 2: 4 ÷ 20 mA<br>0.0 V ÷ 10.0V, if <b>P060</b> = 3: 0 ÷ 10 V<br>0.0 mA ÷ 20.0 mA, if <b>P060</b> = 4: 0 ÷ 20 mA |
|             | <b>Default</b>  | 40   | 4.0mA  |
|             | <b>Level</b>    | ADVANCED   |  |
|             | <b>Address</b>  | 661  |  |
|             | <b>Function</b> | <p>This parameter selects the value for AIN2 input signal for minimum reference, or better the reference set in <b>C028xP061a</b> (Master mode) or in <b>C047xP061a</b> (Slave mode). If motor 2 is active, <b>C071</b> and <b>C090</b> will be used instead of <b>C028</b> and <b>C047</b>; if motor 3 is active, the values set in <b>C114</b> and <b>C133</b> will be used.</p> |  |

**P061a Percentage of Speed Min/Trq Min Producing Min. Reference (Y-axis related to P061)**

|              |                 |  |        |
|--------------|-----------------|--|--------|
| <b>P061a</b> | <b>Range</b>    | 0 ÷ 1000   | 100.0% |
|              | <b>Default</b>  | 1000   | 100.0% |
|              | <b>Level</b>    | ADVANCED   |        |
|              | <b>Address</b>  | 679  |        |
|              | <b>Function</b> | This parameter represents the min. speed percentage (or the min. torque percentage for a torque reference) to be used for the minimum reference set with <b>P061</b> . |        |

**P062 Value of AIN2 Input Producing Max. Reference (X-axis)**

|             |                 |   |  |
|-------------|-----------------|---|--|
| <b>P062</b> | <b>Range</b>    | -100 ÷ 100, if <b>P060</b> = 0<br>-200 ÷ 200, if <b>P060</b> = 1<br>+40 ÷ 200, if <b>P060</b> = 2<br>0 ÷ 100, if <b>P060</b> = 3<br>0 ÷ 200, if <b>P060</b> = 4   | -10.0 V ÷ 10.0 V, if <b>P060</b> = 0: ± 10 V<br>-20.0 mA ÷ 20.0 mA, if <b>P060</b> = 1: ± 20 mA<br>+4.0mA ÷ 20.0 mA, if <b>P060</b> = 2: 4 ÷ 20 mA<br>0.0 V ÷ 10.0V, if <b>P060</b> = 3: 0 ÷ 10 V<br>0.0 mA ÷ 20.0 mA, if <b>P060</b> = 4: 0 ÷ 20 mA |
|             | <b>Default</b>  | 200   | +20.0 mA   |
|             | <b>Level</b>    | ADVANCED  |  |
|             | <b>Address</b>  | 662   |  |
|             | <b>Function</b> | This parameter selects the value for <b>AIN2</b> input signal for maximum reference, or better the reference set in <b>C029xP062a</b> (Master mode) or in <b>C048xP062a</b> (Slave mode). If motor 2 is active, <b>C072</b> and <b>C091</b> will be used instead of <b>C029</b> and <b>C048</b> ; if motor 3 is active, the values set in <b>C115</b> and <b>C134</b> will be used. |  |

**P062a Percentage of Speed Min/Trq Min Producing Max. Reference (Y-axis related to P062)**

|              |                 |  |        |
|--------------|-----------------|--|--------|
| <b>P062a</b> | <b>Range</b>    | 0 ÷ 1000   | 100.0% |
|              | <b>Default</b>  | 1000   | 100.0% |
|              | <b>Level</b>    | ADVANCED   |        |
|              | <b>Address</b>  | 701  |        |
|              | <b>Function</b> | This parameter represents the max. speed percentage (or the min. torque percentage for a torque reference) to be used for the maximum reference set with <b>P062</b> . |        |

**P063 Offset over AIN2 Input**

|             |                 |   |  |
|-------------|-----------------|---|--|
| <b>P063</b> | <b>Range</b>    | -2000 ÷ 2000  | -10.00 V ÷ +10.00 V, if <b>P060</b> = 0 o 3<br>- 20.00 mA ÷ +20,00 mA , if <b>P060</b> = 1,2,4 |
|             | <b>Default</b>  | 0   | 0 V  |
|             | <b>Level</b>    | ADVANCED  |  |
|             | <b>Address</b>  | 663   |  |
|             | <b>Function</b> | This parameter selects the offset correction value of AIN2 analog signal that has been measured.<br>The value set is added to the signal measured before saturation or conversion; its unit of measure is the same as the one of the signal selected for AIN2 analog input. |  |

**P064 Filtering Time over AIN2 Input**

|             |                 |   |              |
|-------------|-----------------|---|--------------|
| <b>P064</b> | <b>Range</b>    | 0 ÷ +65000  | 0 ÷ +65000ms |
|             | <b>Default</b>  | 5   | 5 ms         |
|             | <b>Level</b>    | ADVANCED  |              |
|             | <b>Address</b>  | 664   |              |
|             | <b>Function</b> | This parameter selects the value of the filter time constant of the first command applied to AIN2 input signal when the signal saturation and conversion is over. |              |

**P065 Minimum Reference and START Disabling Threshold**

|             |                 |  |                |
|-------------|-----------------|--|----------------|
| <b>P065</b> | <b>Range</b>    | 0 ÷ +32000   | 0 ÷ +32000 rpm |
|             | <b>Default</b>  | 0  | 0rpm           |
|             | <b>Level</b>    | ADVANCED   |                |
|             | <b>Address</b>  | 665  |                |
|             | <b>Function</b> | <p>If this parameter is other than zero, the current speed reference computed when processing of all active source references is over, <b>it is saturated as an absolute value of this parameter's value</b>. Saturation implies an absolute value, i.e. this parameter determines a "prohibit range" of the reference approx. zero.<br/> Example:<br/> <b>P065</b> = 100 rpm and current speed reference is 500 rpm; if reference drops below 100 rpm, for example down to +50rpm, the value of the active reference is saturated to 100 rpm until reference exceeds 100 rpm again or is <u>lower than -100 rpm</u>; in that case, the preset value will be assigned to the reference.<br/> If also parameter <b>P066</b> is other than zero, the <b>drive disabling function is enabled</b>: if the absolute value of the current speed reference is kept in the "prohibit range" <u>for a time longer than the time set in P066</u>, reference is set to zero and the motor speed decreases following the active ramp up to zero rpm; when the motor speed is equal to zero, the drive will automatically deactivate.<br/> With <b>ENABLE-A</b> and <b>ENABLE-B</b> inputs closed, <b>the drive will automatically reactivate</b> if the reference exceeds the value set in parameter <b>P065</b> as an absolute value.</p> |                |

**NOTE**

Parameter **P065** is active in Master mode only, i.e. when the reference is a direct speed reference not sent from PID with **C294** PID Action = 1:[Reference]).

**NOTE**

Parameter **P065** is active only when the Speed searching and Power Down functions are disabled: **C245=0** and **C225=0**.

**P066 START Disable delay at P065 Threshold**

|             |                 |   |             |
|-------------|-----------------|---|-------------|
| <b>P066</b> | <b>Range</b>    | 0 ÷ 250   | 0 ÷ 250 sec |
|             | <b>Default</b>  | 0   | 0: Disabled |
|             | <b>Level</b>    | ADVANCED  |             |
|             | <b>Address</b>  | 666   |             |
|             | <b>Function</b> | <p>If this parameter is other than zero and if also parameter <b>P065</b> is other than zero, the <b>drive disabling function is enabled</b>: if the absolute value of the current speed reference is kept in the "prohibit range" for a time longer than the time set in <b>P066</b>, reference is set to zero and the motor speed decreases following the active ramp up to zero rpm; when the motor speed is equal to zero, the drive will automatically deactivate.<br/> See also the description of parameter <b>P065</b>.</p> |             |

**P067 Keypad and Terminal Board UP/DOWN Ramp**

|             |                 |   |                         |
|-------------|-----------------|---|-------------------------|
| <b>P067</b> | <b>Range</b>    | 0 ÷ 6501  | 0 sec ÷ 6500s Quadratic |
|             | <b>Default</b>  | 6501  | Quadratic               |
|             | <b>Level</b>    | ADVANCED  |                         |
|             | <b>Address</b>  | 667   |                         |
|             | <b>Function</b> | Reference may be increased or decreased with input digital signals <b>UP</b> and <b>DOWN</b> , or using the <b>▲</b> and <b>▼</b> keys from the keypad (local mode).<br>Reference increment or decrement is obtained by adding to the current reference a quantity which will be increased or decreased with a time ramp.<br>Parameter <b>P067</b> indicates the ramp time to increase the reference from zero to the preset speed (or torque) maximum absolute value, i.e. the max. value between absolute values Spd_Min and Spd_Max (or Trq_Min and Trq_Max).<br>If motor 1 is active, Spd_Min= <b>C028</b> , Spd_Max= <b>C029</b> , Trq_Min= <b>C047</b> , Trq_Max= <b>C048</b> . |                         |

**P068 Storage of UP/DOWN Values at Power Off**

|             |                 |   |                         |
|-------------|-----------------|---|-------------------------|
| <b>P068</b> | <b>Range</b>    | 0 ÷ 1   | 0: Disabled, 1: Enabled |
|             | <b>Default</b>  | 1   | 1: Enabled              |
|             | <b>Level</b>    | ADVANCED  |                         |
|             | <b>Address</b>  | 668   |                         |
|             | <b>Function</b> | If <b>P068</b> =1, the Speed/Torque or PID references added through input digital signals <b>UP</b> and <b>DOWN</b> or with the <b>INC</b> and <b>DEC</b> keys (local mode), are stored at the drive power off and are added to the start reference when the drive is restarted.<br>This function allows storing the reference value obtained with <b>UP</b> and <b>DOWN</b> signals. |                         |

**P068a Reset UP/DOWN Speed/Torque at Stop**

|              |                 |   |               |
|--------------|-----------------|---|---------------|
| <b>P068a</b> | <b>Range</b>    | 0 ÷ 1   | 0: NO, 1: YES |
|              | <b>Default</b>  | 0   | 0: NO         |
|              | <b>Level</b>    | ADVANCED  |               |
|              | <b>Address</b>  | 940   |               |
|              | <b>Function</b> | If <b>P068a</b> =1: [Yes], the Speed/Torque reference sent via the <b>UP/DOWN</b> digital signals or with the <b>▲</b> and <b>▼</b> keys in the keypad is reset whenever the START command for the drive is disabled and the deceleration ramp is finished. |               |

**P068b Reset UP/DOWN PID at Stop**

|              |                 |  |               |
|--------------|-----------------|--|---------------|
| <b>P068b</b> | <b>Range</b>    | 0 ÷ 1  | 0: NO, 1: YES |
|              | <b>Default</b>  | 0  | 0: NO         |
|              | <b>Level</b>    | ADVANCED   |               |
|              | <b>Address</b>  | 941  |               |
|              | <b>Function</b> | If <b>P068b</b> =1: [Yes], the PID reference sent via the <b>UP/DOWN</b> digital signals or via the <b>▲</b> and <b>▼</b> keys in the keypad) is reset whenever the START command for the drive is disabled and the deceleration ramp is finished. |               |

**P068c Reset UP/DOWN Speed/Torque at Source Changeover**

|              |                 |  |               |
|--------------|-----------------|--|---------------|
| <b>P068c</b> | <b>Range</b>    | 0 ÷ 1  | 0: NO, 1: YES |
|              | <b>Default</b>  | 0  | 0: NO         |
|              | <b>Level</b>    | ADVANCED   |               |
|              | <b>Address</b>  | 942  |               |
|              | <b>Function</b> | If <b>P068c</b> =1:[Yes], the Speed/Torque reference sent via the <b>UP/DOWN</b> digital signals or with the ▲ and ▼ keys in the keypad is reset whenever switching from the Remote mode to the Local mode and vice versa (using the <b>LOC/REM</b> key or the LOC/REM digital input, or when a control source switches to the other using the digital input programmed in <b>C179</b> - MDI for source selection, see the DIGITAL INPUTS MENU). |               |

**P068d Reset UP/DOWN PID at Source Changeover**

|              |                 |  |               |
|--------------|-----------------|--|---------------|
| <b>P068d</b> | <b>Range</b>    | 0 ÷ 1  | 0: NO, 1: YES |
|              | <b>Default</b>  | 0  | 0: NO         |
|              | <b>Level</b>    | ADVANCED   |               |
|              | <b>Address</b>  | 943  |               |
|              | <b>Function</b> | If <b>P068d</b> =1: [Yes], the PID reference sent via the <b>UP/DOWN</b> digital signals or with the ▲ and ▼ keys in the keypad is reset whenever switching from the Remote mode to the Local mode and vice versa (using the <b>LOC/REM</b> key or the LOC/REM digital input, or when a control source switches to the other using the digital input programmed in <b>C179</b> - MDI for source selection, see the DIGITAL INPUTS MENU). |               |

**P069 Range of UP/DOWN Reference**

|             |                 |   |                         |
|-------------|-----------------|---|-------------------------|
| <b>P069</b> | <b>Range</b>    | 0 ÷ 1   | 0: Bipolar, 1: Unipolar |
|             | <b>Default</b>  | 1   | 1: Unipolar             |
|             | <b>Level</b>    | ADVANCED  |                         |
|             | <b>Address</b>  | 669   |                         |
|             | <b>Function</b> | If <b>P069</b> =1, the quantity added via the <b>UP/DOWN</b> digital signals or with the ▲ and ▼ keys (Local mode) is unipolar, i.e. it is positive only and has a min. value equal to zero.<br>For bipolar quantities, the added quantity may be negative. |                         |

**P070 JOG reference (Speed/Torque)**

|             |                 |   |         |
|-------------|-----------------|---|---------|
| <b>P070</b> | <b>Range</b>    | ± 100   | ± 100 % |
|             | <b>Default</b>  | 0   | 0 %     |
|             | <b>Level</b>    | ADVANCED  |         |
|             | <b>Address</b>  | 670   |         |
|             | <b>Function</b> | Value of the JOG reference. For speed control, the percentage of the jog reference relates to the maximum speed value of the selected motor (max. value as an absolute value between min. and max. speed parameters); in case of torque control, the percentage of the jog reference relates to the max. torque value of the selected motor (max. value as an absolute value between min. and max. torque limit). |         |

**P071 Value of FIN Producing Min. Reference (X-axis)**

|             |                 |   |                  |
|-------------|-----------------|---|------------------|
| <b>P071</b> | <b>Range</b>    | 1000 ÷ 10000  | 10 kHz ÷ 100 kHz |
|             | <b>Default</b>  | 1000  | 10 kHz           |
|             | <b>Level</b>    | ADVANCED  |                  |
|             | <b>Address</b>  | 671   |                  |
|             | <b>Function</b> | This parameter selects the value of the <b>frequency input</b> signal for minimum reference, or better the reference set in <b>C028xP071a</b> (Master mode) or in <b>C047xP071a</b> (Slave mode). If motor 2 is active, <b>C071</b> and <b>C090</b> will be used instead of <b>C028</b> and <b>C047</b> ; if motor 3 is active, the values set in <b>C114</b> and <b>C133</b> will be used. |                  |

**P071a Percentage of Speed Min/Trq Min Producing Min. Reference (Y-axis related to P071)**

|              |                 |  |        |
|--------------|-----------------|--|--------|
| <b>P071a</b> | <b>Range</b>    | 0 ÷ 1000   | 100.0% |
|              | <b>Default</b>  | 1000   | 100.0% |
|              | <b>Level</b>    | ADVANCED   |        |
|              | <b>Address</b>  | 713  |        |
|              | <b>Function</b> | This parameter represents the min. speed percentage (or the min. torque percentage for a torque reference) to be used for the minimum reference set with <b>P071</b> . |        |

**P072 Value of FIN Producing Max. Reference (X-axis)**

|             |                 |   |                  |
|-------------|-----------------|---|------------------|
| <b>P072</b> | <b>Range</b>    | 1000 ÷ 10000  | 10 kHz ÷ 100 kHz |
|             | <b>Default</b>  | 10000   | 100 kHz          |
|             | <b>Level</b>    | ADVANCED  |                  |
|             | <b>Address</b>  | 672   |                  |
|             | <b>Function</b> | This parameter selects the value of the <b>frequency input</b> signal for maximum reference, or better the reference set in <b>C029xP072a</b> (Master mode) or in <b>C048xP072a</b> (Slave mode). If motor 2 is active, <b>C072</b> and <b>C091</b> will be used instead of <b>C029</b> and <b>C048</b> ; if motor 3 is active, the values set in <b>C115</b> and <b>C134</b> will be used. |                  |

**P072a Percentage of Speed Max/Trq Max Producing Max. Reference (Y-axis related to P072)**

|              |                 |  |        |
|--------------|-----------------|--|--------|
| <b>P072a</b> | <b>Range</b>    | 0 ÷ 1000   | 100.0% |
|              | <b>Default</b>  | 1000   | 100.0% |
|              | <b>Level</b>    | ADVANCED   |        |
|              | <b>Address</b>  | 714  |        |
|              | <b>Function</b> | This parameter represents the max. speed percentage (or the max. torque percentage for a torque reference) to be used for the maximum reference set with <b>P072</b> . |        |

**P073 Value of ECH Producing Min. Reference (X-axis)**

|             |                 |  |             |
|-------------|-----------------|--|-------------|
| <b>P073</b> | <b>Range</b>    | -32000 ÷ 32000   | ± 32000 rpm |
|             | <b>Default</b>  | 0  | 0 rpm       |
|             | <b>Level</b>    | ADVANCED   |             |
|             | <b>Address</b>  | 673  |             |
|             | <b>Function</b> | This parameter selects the value of the <b>Encoder input</b> for minimum reference, or better the reference set in <b>C028xP073a</b> (Master mode) or in <b>C047xP073a</b> (Slave mode). If motor 2 is active, the values set in <b>C071</b> and <b>C090</b> will be used instead of <b>C028</b> and <b>C047</b> ; if motor 3 is active, the values set in <b>C114</b> and <b>C133</b> will be used. |             |

**P073a Percentage of Speed Min/Trq Min Producing Min. Reference (Y-axis related to P073)**

|              |                 |  |        |
|--------------|-----------------|--|--------|
| <b>P073a</b> | <b>Range</b>    | 0 ÷ 1000   | 100.0% |
|              | <b>Default</b>  | 1000   | 100.0% |
|              | <b>Level</b>    | ADVANCED   |        |
|              | <b>Address</b>  | 702  |        |
|              | <b>Function</b> | This parameter represents the max. speed percentage (or the min. torque percentage for a torque reference) to be used for the maximum reference set with <b>P073</b> . |        |

**P074 Value of ECH Producing Max. Reference (X-axis)**

|             |                 |  |             |
|-------------|-----------------|--|-------------|
| <b>P074</b> | <b>Range</b>    | -32000 ÷ 32000   | ± 32000 rpm |
|             | <b>Default</b>  | +1500  | +1500 rpm   |
|             | <b>Level</b>    | ADVANCED   |             |
|             | <b>Address</b>  | 674  |             |
|             | <b>Function</b> | This parameter selects the value of the <b>Encoder input</b> for maximum reference, or better the reference set in <b>C029xP074a</b> (Master mode) or in <b>C048xP074a</b> (Slave mode). If motor 2 is active, <b>C072</b> and <b>C091</b> will be used instead of <b>C029</b> and <b>C048</b> ; if motor 3 is active, the values set in <b>C115</b> and <b>C134</b> will be used. |             |

**P074a Percentage of Speed Max/Trq Max Producing Max. Reference (Y-axis related to P074)**

|              |                 |  |        |
|--------------|-----------------|--|--------|
| <b>P074a</b> | <b>Range</b>    | 0 ÷ 1000   | 100.0% |
|              | <b>Default</b>  | 1000   | 100.0% |
|              | <b>Level</b>    | ADVANCED   |        |
|              | <b>Address</b>  | 703  |        |
|              | <b>Function</b> | This parameter represents the max. speed percentage (or the max. torque percentage for a torque reference) to be used for the maximum reference set with <b>P074</b> . |        |

## 14. MULTISPEED MENU

### 14.1. Overview



**NOTE** See also the INPUTS FOR REFERENCES MENU and the DIGITAL INPUTS MENU.

The Multispeed menu allows defining the values for 15 **preset speed** (or **multispeed**) references set in parameters **P081** to **P098**. Their application method is set in **P080**.

The desired speed is selected through the digital inputs described in the previous section, relating to the **Digital Inputs Menu**.

The following reference ranges that can be programmed with the parameters above:

± 32000 rpm if multispeed unit of measure is → **P100** = 1.00 rpm

± 3200.0 rpm if multispeed unit of measure is → **P100** = 0.10 rpm

± 320.00 rpm if multispeed unit of measure is → **P100** = 0.01 rpm

Use parameters **C155**, **C156**, **C157** and **C158** to set the digital inputs in multispeed mode.

Parameter **P080** defines the functionality of the references set in the preset speed function: PRESET SPEED, SUM SPEED, EXCLUSIVE PRESET SPEED.

If **P080** = **PRESET SPEED**, the speed reference is the value set in the preset speed which is active at that moment. If digital inputs set as **multispeed** are all open (inactive), the speed reference is the reference coming from the sources selected in the **Control Method Menu (C143 to C146)**.

If **P080** = **EXCLUSIVE PRESET SPEED**, the speed reference is the value set in the multispeed which is active at that moment. If digital inputs set as **multispeed** are all open (inactive), no other reference source is considered; the speed reference is zero.

If **P080** = **SUM SPEED**, the speed reference value assigned to the **preset speed** which is active at that moment is summed up to the total amount of the speed references.

**The reference obtained is always saturated by the parameters relating to the min. speed and the max. speed of the selected motor.**

### 14.2. List of Parameters P080 to P100

Table 27: List of parameters P080 to P100

| Parameter   | FUNCTION                   | User Level  | DEFAULT VALUES | MODBUS Address |
|-------------|----------------------------|-------------|----------------|----------------|
| <b>P080</b> | Multispeed function        | BASIC       | 0:Preset Speed | 680            |
| <b>P081</b> | Output speed Mspd1         | BASIC       | 0.00 rpm       | 681            |
| <b>P083</b> | Output speed Mspd2         | BASIC       | 0.00 rpm       | 683            |
| <b>P085</b> | Output speed Mspd3         | BASIC       | 0.00 rpm       | 685            |
| <b>P087</b> | Output speed Mspd4         | ADVANCED    | 0.00 rpm       | 687            |
| <b>P088</b> | Output speed Mspd5         | ADVANCED    | 0.00 rpm       | 688            |
| <b>P089</b> | Output speed Mspd6         | ADVANCED    | 0.00 rpm       | 689            |
| <b>P090</b> | Output speed Mspd7         | ADVANCED    | 0.00 rpm       | 690            |
| <b>P091</b> | Output speed Mspd8         | ADVANCED    | 0.00 rpm       | 691            |
| <b>P092</b> | Output speed Mspd9         | ADVANCED    | 0.00 rpm       | 692            |
| <b>P093</b> | Output speed Mspd10        | ADVANCED    | 0.00 rpm       | 693            |
| <b>P094</b> | Output speed Mspd 11       | ADVANCED    | 0.00 rpm       | 694            |
| <b>P095</b> | Output speed Mspd 12       | ADVANCED    | 0.00 rpm       | 695            |
| <b>P096</b> | Output speed Mspd 13       | ADVANCED    | 0.00 rpm       | 696            |
| <b>P097</b> | Output speed Mspd 14       | ADVANCED    | 0.00 rpm       | 697            |
| <b>P098</b> | Output speed Mspd 15       | ADVANCED    | 0.00 rpm       | 698            |
| <b>P099</b> | Fire Mode speed            | ENGINEERING | 750 rpm        | 699            |
| <b>P100</b> | Multispeed unit of measure | ADVANCED    | 2: 1.0 rpm     | 700            |

**P080 Multispeed Function**

|             |                 |  |  |
|-------------|-----------------|--|--|
| <b>P080</b> | <b>Range</b>    | 0 ÷ 2  | 0: Preset Speed,<br>1: Sum Speed,<br>2: Exclusive Preset Speed |
|             | <b>Default</b>  | 0  | 0: Preset Speed  |
|             | <b>Level</b>    | BASIC  |  |
|             | <b>Address</b>  | 680  |  |
|             | <b>Function</b> | <p>Defines the functionality of the multispeed values for the global speed reference. Three functions are available:</p> <ul style="list-style-type: none"> <li>• 0: [ Preset Speed ] → the selected <b>multispeed</b> is the actual rpm value (upon limit due to min. and max. speed parameters for the selected motor) of the motor speed reference. If no <b>multispeed</b> is selected (<i>no digital input programmed for multispeed selection is activated, or all digital inputs programmed for multispeed selection are deactivated</i>), the speed reference is the reference for the sources set in the CONTROL METHOD MENU.</li> <li>• 1: [ Sum Speed ] → the reference relating to the selected multispeed is considered as the sum of the references for the other reference sources selected in the CONTROL METHOD MENU.</li> <li>• 2: [ Exclusive Preset Speed ] → the selected multispeed is the actual rpm value (upon saturation due to min. and max. speed parameters for the selected motor) of the motor speed reference. Unlike function 0 [Preset Speed], if no multispeed is selected (<i>no digital input programmed for multispeed selection is activated, or all digital inputs programmed for multispeed selection are deactivated</i>) <b>the speed reference is zero.</b></li> </ul> |  |

**P081 to P098 Output Speed Mspd n.1 (/15)**

|                  |                 |   |            |
|------------------|-----------------|---|------------|
| <b>P081÷P098</b> | <b>Range</b>    | -32000 ÷ 32000  | ±32000 rpm |
|                  | <b>Default</b>  | 0   | 0.00 rpm   |
|                  | <b>Level</b>    | From <b>P081</b> to <b>P085</b> : BASIC<br>From <b>P087</b> to <b>P098</b> : ADVANCED   |            |
|                  | <b>Address</b>  | 681÷698   |            |
|                  | <b>Function</b> | <p>This parameter sets the multispeed output speed selected through the relevant digital inputs (Table 96). The multispeed value is scaled based on the unit of measure set in <b>P100</b>.</p> <p>The reference resulting from the multispeed selected through the relevant digital inputs will be computed based on the setting of parameter <b>P080</b>.</p> |            |

**P099 Fire Mode Speed**

|             |                 |   |            |
|-------------|-----------------|---|------------|
| <b>P099</b> | <b>Range</b>    | -32000 ÷ 32000  | ±32000 rpm |
|             | <b>Default</b>  | 750   | 750.00 rpm |
|             | <b>Level</b>    | ENGINEERING   |            |
|             | <b>Address</b>  | 699   |            |
|             | <b>Function</b> | Determines the value of the output speed in Fire Mode. The Fire Mode speed depends on the unit of measure programmed in <b>P100</b> . |            |

**P100 Multispeed Unit of Measure**

|             |                 |   |                              |
|-------------|-----------------|---|------------------------------|
| <b>P100</b> | <b>Range</b>    | 0 ÷ 2   | 0: [0.01 rpm] ÷ 2: [1.0 rpm] |
|             | <b>Default</b>  | 2   | 2: [1.0 rpm]                 |
|             | <b>Level</b>    | ADVANCED  |                              |
|             | <b>Address</b>  | 700   |                              |
|             | <b>Function</b> | Determines the unit of measure considered for the 15 allowable multispeed values and the Fire Mode speed in <b>P099</b> . |                              |

**CAUTION**

When changing the unit of measure of the multispeed values in **P100**, the preset speed values for the multispeed and Fire Mode values will be RECOMPUTED.

## 15. PID MULTIREFERENCES MENU

### 15.1. Overview

This menu includes the parameters for the utilisation and allocation of PID Multireferences from digital inputs. The reference sources are based on the setup in parameters **C285** to **C287** (see the PID CONFIGURATION MENU). The overall reference also depends on the multireferences that are already set (if any) or on the reduction percent of the reference itself (see the REFERENCE VARIATION PERCENT MENU).

Configuration example:

#### PID Configuration Menu

**C285** Source of PID reference 1 = 2: AIN1

**C286** Source of PID reference 2 = 0: Disable

**C287** Source of PID reference 3 = 0: Disable

#### Digital Inputs Menu

**C188a** Input for PID Multireference 1 = 7: MDI7

**C188b** Input for PID Multireference 2 = 8: MDI8

**C188c** Input for PID Multireference 3 = 0: Disable

#### PID Multireferences Menu

**P081a** PID Reference 1 (Mref 1) = 1.0 bars

**P082a** PID Reference 2 (Mref 2) = 1.5 bars

**P083a** PID Reference 3 (Mref 3) = 2.5 bars

#### PID Parameters Menu

**P257** Gain for PID scaling = 0.1

When AIN1 analog input is set to 100%, the pressure reference is 10 bars  
( $100\% \cdot P257 = 10.0$ ).

Supposing that AIN1 is set to 43%, the references below are obtained based on the combination of the digital inputs configured as multireferences, and based on the function allocated to parameter **P080a**.

**P080a = 0: Preset Ref.** If both digital inputs configured as Multireferences are not activated, the overall reference is given from AIN1 analog input selected as the first PID reference (**C285**):

| P080a Multireference Function = Preset Ref. |      |                   |
|---|------|-------------------|
| MDI8  | MDI7 | Overall reference |
| 0   | 0    | 4.3 bars          |
| 0   | 1    | 1.0 bars          |
| 1   | 0    | 1.5 bars          |
| 1   | 1    | 2.5 bars          |

**P80a = 1: Sum Ref.** If both digital inputs configured as Multireference are inactive, the overall reference is given from AIN1 analog input selected as the first PID reference (**C285**). For the combinations where at least one of the digital inputs configured as multireference is active, the resulting reference is the sum of the value for AIN1 plus the value for the selected multireference.

| P080a Multireference Function = Exclusive Preset Ref. |      |                   |
|---|------|-------------------|
| MDI8  | MDI7 | Overall reference |
| 0   | 0    | 4.3 bars          |
| 0   | 1    | 5.3 bars          |
| 1   | 0    | 5.8 bars          |
| 1   | 1    | 6.8 bars          |

P80a= 2: Exclusive Preset Ref. If no Multireference is activated, the overall reference is null.

| P080a Multireference Function = 2: Exclusive Preset Ref. |      |                   |
|--|------|-------------------|
| MDI8   | MDI7 | Overall Reference |
| 0  | 0    | 0.0 bars          |
| 0  | 1    | 1.0 bars          |
| 1  | 0    | 1.5 bars          |
| 1  | 1    | 2.5 bars          |

## 15.2. List of Parameters P080a to P099a

Table 28: List of parameters P080a ÷ P099a

| Parameter | FUNCTION                     | User Level  | DEFAULT VALUE | MODBUS Address |
|-----------|------------------------------|-------------|---------------|----------------|
| P080a     | PID Multireference function  | ENGINEERING | 0             | 944            |
| P081a     | PID Multireference 1 (Mref1) | ENGINEERING | 0             | 945            |
| P082a     | PID Multireference 2 (Mref2) | ENGINEERING | 0             | 946            |
| P083a     | PID Multireference 3 (Mref3) | ENGINEERING | 0             | 947            |
| P084a     | PID Multireference 4 (Mref4) | ENGINEERING | 0             | 948            |
| P085a     | PID Multireference 5 (Mref5) | ENGINEERING | 0             | 949            |
| P086a     | PID Multireference 6 (Mref6) | ENGINEERING | 0             | 986            |
| P087a     | PID Multireference 7 (Mref7) | ENGINEERING | 0             | 987            |
| P099a     | PID Reference in Fire Mode   | ENGINEERING | 50%           | 988            |

### P080a Multireference

|       |          |  |   |
|-------|----------|--|---|
| P080a | Range    | 0 ÷ 2  | 0: Preset Ref<br>1: Sum Ref<br>2: Exclusive Preset Ref. |
|       | Default  | 0  | 0: [Preset Ref]   |
|       | Level    | ENGINEERING  |   |
|       | Address  | 944  |   |
|       | Function | This parameter sets if the PID reference resulting from the selection of a digital multireference is to be considered either as the unique active reference or as summed up to the other configured PID reference sources (see example above). |   |

### P081a÷P087a PID Multireference 1÷7

|             |          |   |       |
|-------------|----------|---|-------|
| P081a÷P087a | Range    | -1000 ÷ +1000   | ±1000 |
|             | Default  | 0   | 0     |
|             | Level    | ENGINEERING   |       |
|             | Address  | 945÷949, 986÷987  |       |
|             | Function | <p>This is the value of the PID reference selected with the corresponding combination of the digital inputs programmed as multireferences.</p> <p>The reference is expressed in the unit of measure set with <b>P267</b> (see the DISPLAY/KEYPAD MENU) and is based on parameter <b>P257</b> (Gain for PID Scaling).</p> <p>Example: The max. value for the PID feedback is 100%. This value corresponds to a level of 25m in a tank.</p> <p>When <b>P257</b> = 0.25, 100% of PID feedback corresponds to 25 metres. When setting a reference level of 15 meters, multireference 1 shall be set as <b>P081a</b> = 15.0 m.</p> |       |

**P099a PID Reference in Fire Mode**

|              |                 |   |        |
|--------------|-----------------|---|--------|
| <b>P099a</b> | <b>Range</b>    | -1000 ÷ 1000  | ±1000  |
|              | <b>Default</b>  | 500   | 50.0 % |
|              | <b>Level</b>    | ENGINEERING   |        |
|              | <b>Address</b>  | 988   |        |
|              | <b>Function</b> | This parameter sets the value of the PID reference when in Fire Mode. The value of the PID reference depends on the scale factor set in <b>P257</b> . |        |

## 16. PROHIBIT SPEED MENU

### 16.1. Overview

This menu allows setting prohibit speed ranges that the motor cannot maintain at constant rpm due to mechanical resonance.

Three prohibit speed ranges are available: 3 intermediate values of the speed range and their semi-amplitude (one for all ranges).

In this way, the speed reference value is never included in one of the preset speed ranges; when decreasing, if the speed reference matches with the max. allowable value of a prohibit speed range, the value assigned to the reference is given by the min. allowable value of the speed range, and vice versa when the reference is increasing.

The discontinuity of the speed reference has no effect on the actual speed of the connected motor, because this will vary with continuity until it reaches the new rpm value of the speed reference.

The intermediate values of the prohibit speed ranges are to be intended as absolute values (independent of the reference sign, +/-).

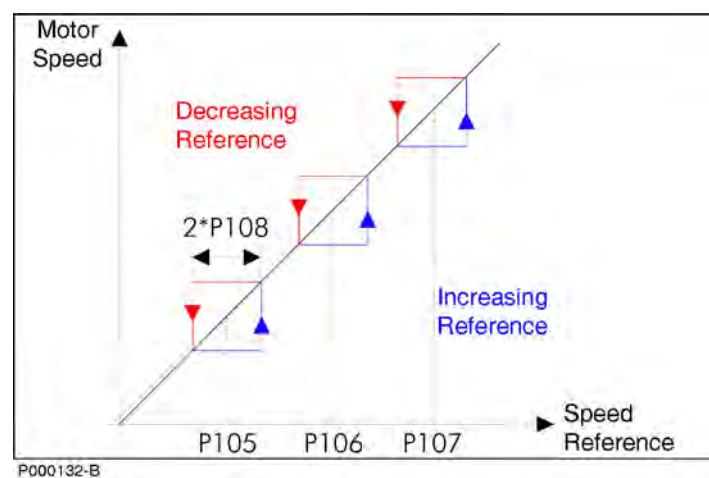

Figure 12: Prohibit Speed ranges

Figure 12 illustrates different trends of the speed reference when it matches with the max. allowable value of a prohibit speed range when decreasing (red) or when it matches with the min. allowable value of a prohibit speed range when increasing (blue).

Example:

**P105** = 500 rpm Prohibit speed 1

**P106** = 650 rpm Prohibit speed 2

**P107** = 700 rpm Prohibit speed 3

**P108** = 50 rpm Semi-amplitude of prohibit speed ranges

| Range Number | Min. Allowable Value | Max. Allowable Value |
|--------------|----------------------|----------------------|
| 1            | 450 rpm              | 550 rpm              |
| 2            | 600 rpm              | 700 rpm              |
| 3            | 650 rpm              | 750 rpm              |

In this case, the second and third prohibit ranges partially match, because the max. allowable value of the second range (700 rpm) is higher than the min. allowable value of the third range (650 rpm), thus forming a prohibit speed range ranging from 600 rpm to 750 rpm.

## 16.2. List of Parameters P105 to P108

Table 29: List of parameters P105 to P108

| Parameter | FUNCTION                                   | User Level | MODBUS Address |
|-----------|--|------------|----------------|
| P105      | Prohibit speed 1                           | ADVANCED   | 705            |
| P106      | Prohibit speed 2                           | ADVANCED   | 706            |
| P107      | Prohibit speed 3                           | ADVANCED   | 707            |
| P108      | Hysteresis (band) of prohibit speed ranges | ADVANCED   | 708            |

### P105 (P106, P107) Prohibit Speed 1 (2, 3)

| P105 | Range    | 0 ÷ 32000   | 0 ÷ 32000 rpm |
|------|----------|---|---------------|
|      | Default  | 0   | 0 rpm         |
|      | Level    | ADVANCED  |               |
|      | Address  | 705<br>706<br>707   |               |
|      | Function | Determines the intermediate value of the first prohibit speed range. This value is to be considered as an absolute value, i.e. independent of the speed reference sign (+/-). |               |

### P108 Hysteresis (band) of Prohibit Speed Ranges

| P108 | Range    | 0 ÷ 5000  | 0 ÷ 5000 rpm |
|------|----------|---|--------------|
|      | Default  | 0   | 0 rpm        |
|      | Level    | ADVANCED  |              |
|      | Address  | 708   |              |
|      | Function | Sets the semi-amplitude of the prohibit speed ranges. |              |

## 17. REFERENCE VARIATION PERCENT MENU

### 17.1. Overview

The Reference Variation Percent Menu allows defining the variation values of the speed/torque or PID instant reference to be entered through digital inputs that have been properly programmed.

As per the selection of the variation percentage programmed to the reference and given by the combination of digital inputs configured with parameters **C175 ÷ C177**, please refer to the DIGITAL INPUTS MENU.

The parameters included in this menu represent seven speed/torque or PID variation options to be applied to the speed reference.

Variation may range from **-100.0% to 100.0%** of the instant reference given by the addition of all the selected sources.

Example:

**P115=** 0.0% Variation percent of reference 1  
**P116=** 50.0% Variation percent of reference 2  
**P117=** -80.0% Variation percent of reference 3

Based on the speed/torque or PID variation selected through digital inputs, the speed reference at constant speed will be as follows:

Variation 1: the current reference with no changes (no effect).

Variation 2: the current reference increased by 50.0%.

Variation 3: the current reference decreased by 80.0%.



**NOTE**

Whatever the speed/torque reference value resulting from the application of a speed variation, the value used to control the motor is saturated at max. and min. speed/torque values set in the parameters relating to the selected motor.

Speed control (example):

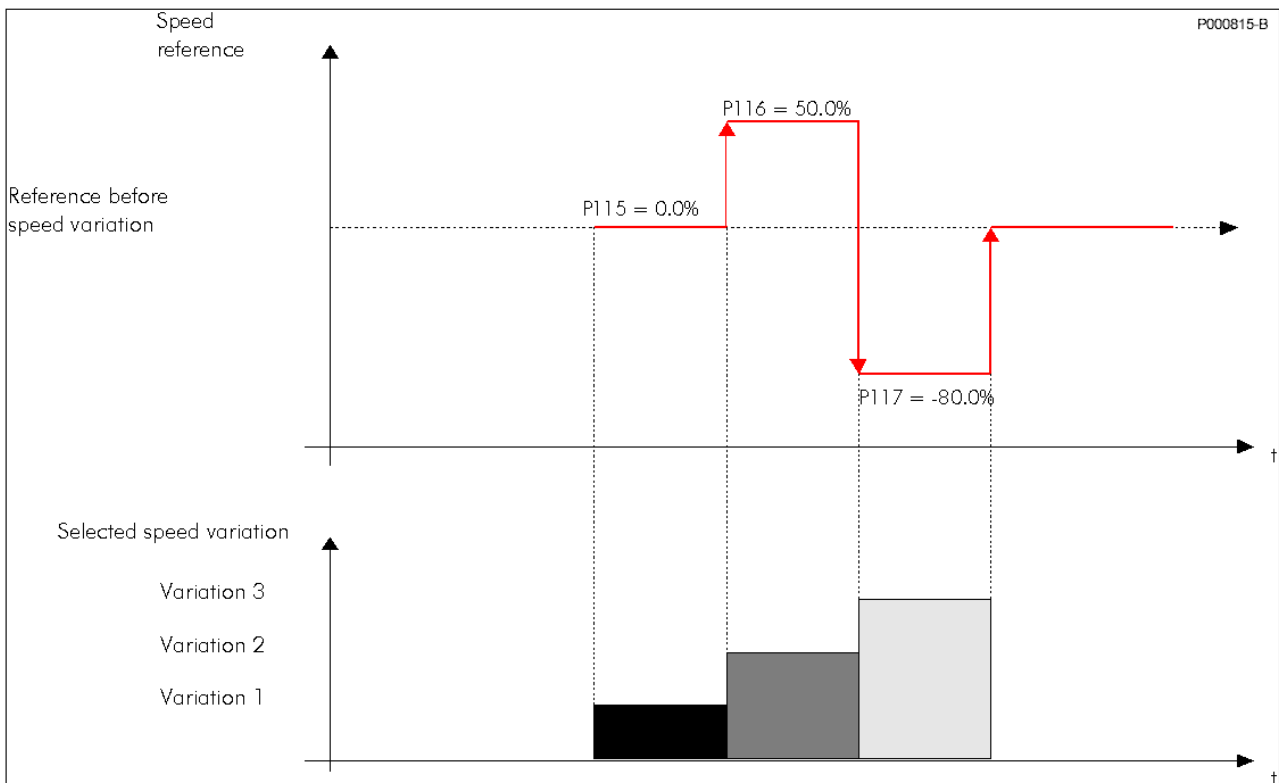

Figure 13: Speed Control (example)

## 17.2. List of Parameters P115 to P121

Table 30: List of parameters P115 to P121

| Parameter | FUNCTION                        | User Level  | Default Values | MODBUS Address |
|-----------|---------------------------------|-------------|----------------|----------------|
| P115      | Reference variation percent n.1 | ENGINEERING | 0.0%           | 715            |
| P116      | Reference variation percent n.2 | ENGINEERING | 0.0%           | 716            |
| P117      | Reference variation percent n.3 | ENGINEERING | 0.0%           | 717            |
| P118      | Reference variation percent n.4 | ENGINEERING | 0.0%           | 718            |
| P119      | Reference variation percent n.5 | ENGINEERING | 0.0%           | 719            |
| P120      | Reference variation percent n.6 | ENGINEERING | 0.0%           | 720            |
| P121      | Reference variation percent n.7 | ENGINEERING | 0.0%           | 721            |

### P115 (+ P121) Reference Variation Percent n.1 (+n.7)

|                      |                 |  |         |
|----------------------|-----------------|--|---------|
| <b>P115 (+ P121)</b> | <b>Range</b>    | ±1000  | ±100.0% |
|                      | <b>Default</b>  | 0  | 0.0%    |
|                      | <b>Level</b>    | ENGINEERING  |         |
|                      | <b>Address</b>  | 715 (+721)   |         |
|                      | <b>Function</b> | These parameters define the variation percent of the current reference ( <b>M000</b> for speed control, <b>M007</b> for torque control, <b>M018</b> if PID control is activated) to be considered as a ramp reference when selecting variation percent 1 (+7). |         |

## 18. SPEED LOOP AND CURRENT BALANCING MENU

### 18.1. Overview

The SPEED LOOP AND CURRENT BALANCING MENU, for VTC and FOC controls, allows setting the parameter values of the speed regulators for the three connected motors and to manually adjust the motor current balancing (see parameter **P152**).

The speed regulator for each motor has two parameterization functions: two integral terms, two proportional terms and two speed error thresholds (expressed as a percentage of the motor rated speed).

The response of the speed regulator can be dynamically linked with the speed error; in this way, the speed regulator will be more sensitive to remarkable speed errors and less sensitive to negligible speed errors.

Factory setting: because two identical error thresholds are set, only two parameters are used: **P126** (maximum integral time) and **P128** (minimum proportional constant).

The setup of min. integral time and max. proportional constant is enabled provided that two different error thresholds are used.

Example:

|             |       |      |   |
|-------------|-------|------|---|
| <b>P125</b> | 100   | [ms] | Minimum integral time for maximum error |
| <b>P126</b> | 500   | [ms] | Integral time for minimum error         |
| <b>P128</b> | 10.00 |      | Proportional constant for minimum error |
| <b>P129</b> | 25.00 |      | Proportional constant for maximum error |
| <b>P130</b> | 2     | [%]  | Minimum error threshold                 |
| <b>P131</b> | 20    | [%]  | Maximum error threshold                 |

**Error ≤ P130**

For speed errors lower than or equal to 2% of the motor rated speed, the speed regulator adopts parameters **P126** and **P128**.

**Error ≥ P131**

If the speed error exceeds the second error threshold, the speed regulator adopts parameters **P125** and **P129**.

**P130 < Error < P131**

When the speed error is included between the two error thresholds, the speed regulator will use coefficients that are dynamically linked with the speed error (see figure below).

$$\begin{aligned} \text{Integral coefficient} &= (1/P126) + [(err\% - P130) * (1/P125 - 1/P126) / (P131 - P130)] \\ \text{Proportional coefficient} &= P128 + [(err\% - P130) * (P129 - P128) / (P131 - P130)] \end{aligned}$$

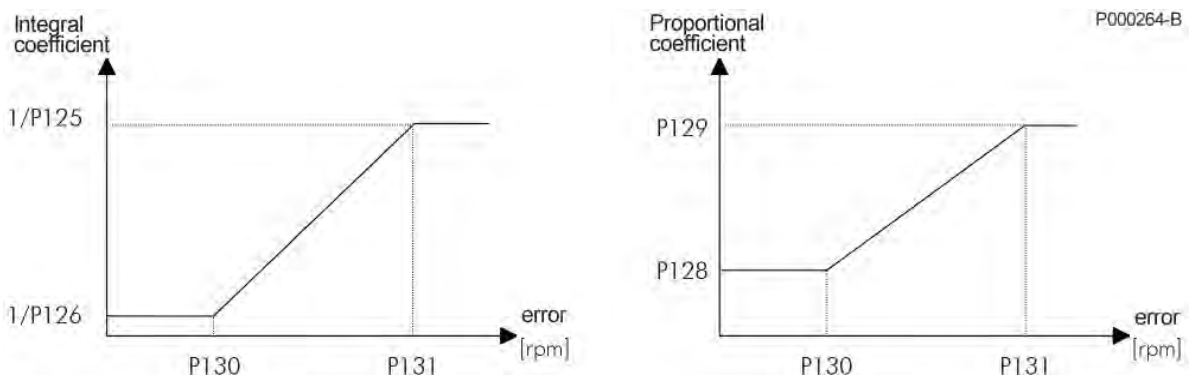

Figure 14: Dual Parameterization function (example)

## 18.2. List of Parameters P125 to P153

Table 31: List of parameters P125 to P153

| Parameter | FUNCTION                                   | User Level  | Default Values | MODBUS Address |
|-----------|--|-------------|----------------|----------------|
| P125      | Mot1 Integral time for maximum error       | BASIC       | 500 ms         | 725            |
| P126      | Mot1 Integral time for minimum error       | BASIC       | 500 ms         | 726            |
| P128      | Mot1 Prop. coefficient for minimum error   | BASIC       | 10.00          | 728            |
| P129      | Mot1 Prop. coefficient for maximum error   | BASIC       | 10.00          | 729            |
| P130      | Mot1 Minimum error threshold               | BASIC       | 1.00%          | 730            |
| P131      | Mot1 Maximum error threshold               | BASIC       | 1.00%          | 731            |
| P135      | Mot2 Integral time for maximum error       | BASIC       | 500 ms         | 735            |
| P136      | Mot2 Integral time for minimum error       | BASIC       | 500 ms         | 736            |
| P138      | Mot2 Prop. coefficient for minimum error   | BASIC       | 10.00          | 738            |
| P139      | Mot2 Prop. coefficient for maximum error   | BASIC       | 10.00          | 739            |
| P140      | Mot2 Min. error threshold                  | BASIC       | 1.00%          | 740            |
| P141      | Mot2 Max. error threshold                  | BASIC       | 1.00%          | 741            |
| P145      | Mot3 Integral time for maximum error       | BASIC       | 500 ms         | 745            |
| P146      | Mot3 Integral time for minimum error       | BASIC       | 500 ms         | 746            |
| P148      | Mot3 Prop. coefficient for minimum error   | BASIC       | 10.00          | 748            |
| P149      | Mot3 Prop. coefficient for maximum error   | BASIC       | 10.00          | 749            |
| P150      | Mot3 Min. error threshold                  | BASIC       | 1.00%          | 750            |
| P151      | Mot3 Max. error threshold                  | BASIC       | 1.00%          | 751            |
| P152      | Symmetry regulation of three-phase current | ENGINEERING | 0%             | 752            |
| P153      | VTC Speed Error Filter Time Constant       | ENGINEERING | 10 ms          | 753            |

### P125 (P135, P145) Integral Time for Maximum Error

|  |          |   |                            |
|--|----------|---|----------------------------|
| P125 (Motor n.1)<br>P135 (Motor n.2)<br>P145 (Motor n.3) | Range    | 1÷ 32000  | 0.001÷ 32.000 [Disable] ms |
|  | Default  | 500   | 500 ms                     |
|  | Level    | BASIC   |                            |
|  | Address  | 725<br>735<br>745   |                            |
|  | Control  | VTC and FOC   |                            |
|  | Function | This parameter sets the min. integral time for the speed regulator. It may be accessed only if the min. and max. error thresholds are different (P130≠P131 for Motor1, P140≠P141 for Motor2, P150≠P151 for Motor3). |                            |

### P126 (P136, P146) Integral Time for Minimum Error

|  |          |   |                            |
|--|----------|---|----------------------------|
| P126 (Motor n.1)<br>P136 (Motor n.2)<br>P146 (Motor n.3) | Range    | 1÷ 32000  | 0.001÷ 32.000 [Disable] ms |
|  | Default  | 500   | 500 ms                     |
|  | Level    | BASIC   |                            |
|  | Address  | 726<br>736<br>746   |                            |
|  | Control  | VTC and FOC   |                            |
|  | Function | This parameter sets the max. integral time for the speed regulator. |                            |

**P128 (P138, P148) Proportional Coefficient for Minimum Error**

|   |                 |   |               |
|---|-----------------|---|---------------|
| <b>P128 (Motor n.1)</b><br><b>P138 (Motor n.2)</b><br><b>P148 (Motor n.3)</b> | <b>Range</b>    | 0 ÷ 65000   | 0.00 ÷ 650.00 |
|   | <b>Default</b>  | 1000  | 10.00         |
|   | <b>Level</b>    | BASIC   |               |
|   | <b>Address</b>  | 728,738,748   |               |
|   | <b>Control</b>  | VTC and FOC   |               |
|   | <b>Function</b> | This parameter sets the min. proportional coefficient for the speed regulator. Default value (10): if a speed error of 1% occurs, the regulator will require 10% of the motor rated torque. |               |

**P129 (P139, P149) Proportional Coefficient for Maximum Error**

|   |                 |   |               |
|---|-----------------|---|---------------|
| <b>P129 (Motor n.1)</b><br><b>P139 (Motor n.2)</b><br><b>P149 (Motor n.3)</b> | <b>Range</b>    | 0 ÷ 65000   | 0.00 ÷ 650.00 |
|   | <b>Default</b>  | 1000  | 10.00         |
|   | <b>Level</b>    | BASIC   |               |
|   | <b>Address</b>  | 729,739,749   |               |
|   | <b>Control</b>  | VTC and FOC   |               |
|   | <b>Function</b> | This parameter sets the max. proportional coefficient for the speed regulator. Default value (10): if a speed error of 1% occurs, the regulator will require 10% of the motor rated torque. This parameter may be accessed only if the min. and max. error thresholds are different (P130 ≠ P131 for Motor1, P140 ≠ P141 for Motor2, P150 ≠ P151 for Motor3). |               |

**P130 (P140, P150) Min. Error Threshold**

|   |                 |   |               |
|---|-----------------|---|---------------|
| <b>P130 (Motor n.1)</b><br><b>P140 (Motor n.2)</b><br><b>P150 (Motor n.3)</b> | <b>Range</b>    | 0 ÷ 32000   | 0.00 ÷ 320.00 |
|   | <b>Default</b>  | 100   | 1.00%         |
|   | <b>Level</b>    | BASIC   |               |
|   | <b>Address</b>  | 730,740,750   |               |
|   | <b>Control</b>  | VTC and FOC   |               |
|   | <b>Function</b> | This parameter determines the min. error threshold. In case of speed errors lower than or equal to the min. threshold, parameters P126 and P128 will be used. |               |

**P131 (P141, P151) Max. Error Threshold**

|   |                 |   |               |
|---|-----------------|---|---------------|
| <b>P131 (Motor n.1)</b><br><b>P141 (Motor n.2)</b><br><b>P151 (Motor n.3)</b> | <b>Range</b>    | 0 ÷ 32000   | 0.00 ÷ 320.00 |
|   | <b>Default</b>  | 100   | 1.00%         |
|   | <b>Level</b>    | BASIC   |               |
|   | <b>Address</b>  | 731,741,751   |               |
|   | <b>Control</b>  | VTC and FOC   |               |
|   | <b>Function</b> | This parameter sets the max. error threshold. If P130 = P131 or in case of speed errors greater than or equal to the max. threshold, parameters P125 and P129 will be used. |               |

**P152 Symmetry Regulation of Three-phase Current**

|             |                 |   |        |
|-------------|-----------------|---|--------|
| <b>P152</b> | <b>Range</b>    | ± 100   | ± 100% |
|             | <b>Default</b>  | 0   | 0%     |
|             | <b>Level</b>    | ENGINEERING   |        |
|             | <b>Address</b>  | 752   |        |
|             | <b>Function</b> | This parameter affects three-phase current balancing. It must be used when dissymmetry of the motor currents occurs, especially when no-load currents are delivered and the motor rotates at low rpm. |        |

**P153 VTC Speed Error Filter Time Constant**

|             |                 |   |              |
|-------------|-----------------|---|--------------|
| <b>P153</b> | <b>Range</b>    | 0 ÷ 32000   | 0 ÷ 32000 ms |
|             | <b>Default</b>  | 10  | 10 ms        |
|             | <b>Level</b>    | ENGINEERING   |              |
|             | <b>Address</b>  | 753   |              |
|             | <b>Control</b>  | VTC   |              |
|             | <b>Function</b> | Input speed error filter time constant, in speed loop of VTC control. |              |

## 19. FOC REGULATORS MENU

### 19.1. Overview



**NOTE** Please refer to the MOTOR CONFIGURATION MENU as well.



**NOTE** This menu may be accessed only if the FOC control is programmed for one of the connected motors (**C010=2** for motor n.1, **C053=2** for motor n.2, **C096=2** for motor n.3).

The FOC control has the same basic structure as that of any classic field oriented control. The inner loops of FOC control are **two PI current regulators** having the same parameterization. The first regulator controls **Iq torque current**; the second regulator controls **Id flux current**.

**Iq Torque current** is computed based on the required torque set-point.

In **Slave mode** (torque reference), the required set-point comes from the external reference; in **Master mode**, the torque set-point is given by the output of the **speed regulator** (see the SPEED LOOP AND CURRENT BALANCING MENU) for the regulation of the motor speed of rotation.

**Id Flux current** results from the output of the **flux regulator**, ensuring that the connected motor is always properly fluxed.

This menu allows accessing the current PI regulators and flux regulators for the FOC control.

### 19.2. List of Parameters P155 to P173

Table 32: List of parameters P155 to P173

| Parameter   | FUNCTION   | User Level  | Default Values | MODBUS Address |
|-------------|--|-------------|----------------|----------------|
| <b>P155</b> | Current regulator proportional constant, Mot n.1 | ENGINEERING | 3.00           | 755            |
| <b>P156</b> | Current regulator integral time, Mot n.1         | ENGINEERING | 20.0 ms        | 756            |
| <b>P158</b> | Flux regulator proportional constant, Mot n.1    | ENGINEERING | 0.00           | 758            |
| <b>P159</b> | Flux regulator integral time, Mot n.1            | ENGINEERING | 33 ms          | 759            |
| <b>P162</b> | Current regulator proportional constant, Mot n.2 | ENGINEERING | 3.00           | 762            |
| <b>P163</b> | Current regulator integral time, Mot n.2         | ENGINEERING | 20.0 ms        | 763            |
| <b>P165</b> | Flux regulator proportional constant, Mot n.2    | ENGINEERING | 0.00           | 765            |
| <b>P166</b> | Flux regulator integral time, Mot n.2            | ENGINEERING | 33 ms          | 766            |
| <b>P169</b> | Current regulator proportional constant, Mot n.3 | ENGINEERING | 3.00           | 769            |
| <b>P170</b> | Current regulator integral time, Mot n.3         | ENGINEERING | 20.0 ms        | 770            |
| <b>P172</b> | Flux regulator proportional constant, Mot n.3    | ENGINEERING | 0.00           | 772            |
| <b>P173</b> | Flux regulator integral time, Mot n.3            | ENGINEERING | 33 ms          | 773            |

**P155 (P162, P169) Current Regulator Proportional Constant**

|   |                 |  |               |
|---|-----------------|--|---------------|
| <b>P155 (Motor n.1)</b><br><b>P162 (Motor n.2)</b><br><b>P169 (Motor n.3)</b> | <b>Range</b>    | 0 ÷ 65000  | 0.00 ÷ 650.00 |
|   | <b>Default</b>  | 300  | 3.00          |
|   | <b>Level</b>    | ENGINEERING  |               |
|   | <b>Address</b>  | 755<br>762<br>769  |               |
|   | <b>Control</b>  | FOC  |               |
|   | <b>Function</b> | <p><b>Kp</b> Proportional coefficient of <b>PI</b> current regulator Id and Iq in field rotary reference for motor n.1<br/> <b>(P162 and P169 relate to motors 2 and 3).</b><br/>                     The regulator's structure is as follows:<br/>                     error = Set_Point – Measure;<br/>                     integral_status = integral_status + error *<b>Ki</b>*<b>Ts</b>;<br/>                     Output = <b>Kp</b>*error + integral_status;<br/>                     where Kp is the proportional coefficient<br/> <b>Ki</b> is the integral coefficient = 1/Ti , where Ti is the integral time<br/> <b>Ts</b> is the regulator operating time (ranging from 200 to 400 microseconds based on carrier frequency).</p> |               |



**NOTE**

This parameter is **automatically computed and saved** when the Autotuning procedure is performed (see the AUTOTUNE MENU).

**P156 (P163, P170) Current Regulator Integral Time**

|   |                 |   |                         |
|---|-----------------|---|-------------------------|
| <b>P156 (Motor n.1)</b><br><b>P163 (Motor n.2)</b><br><b>P170 (Motor n.3)</b> | <b>Range</b>    | 1 ÷ 32000   | 1.0 ÷ 32000. (Disabled) |
|   | <b>Default</b>  | 200   | 20.0 ms                 |
|   | <b>Level</b>    | ENGINEERING   |                         |
|   | <b>Address</b>  | 756<br>763 (motor n.2)<br>770 (motor n.3)   |                         |
|   | <b>Control</b>  | FOC   |                         |
|   | <b>Function</b> | <p><b>Ti</b> Integral time of <b>PI</b> current regulator Id and Iq in the field rotary reference for motor n.1<br/> <b>(P166 and P170 relate to motors 2 and 3).</b><br/>                     The regulator's structure is as follows:<br/>                     error = Set_Point – Measure;<br/>                     integral_status = integral_status + error *<b>Ki</b>*<b>Ts</b>;<br/>                     Output = <b>Kp</b>*error + integral_status;<br/>                     where Kp is the proportional coefficient<br/> <b>Ki</b> is the integral coefficient = 1/Ti , where Ti is the integral time<br/> <b>Ts</b> is the regulator operating time (ranging from 200 to 400 microseconds based on carrier frequency).</p> |                         |



**NOTE**

This parameter is **automatically computed and saved** when the Autotuning procedure is performed (see the AUTOTUNE MENU).

**P158 (P165, P172) Flux Regulator Proportional Constant**

|   |                 |   |               |
|---|-----------------|---|---------------|
| <b>P158 (Motor n.1)</b><br><b>P165 (Motor n.2)</b><br><b>P172 (Motor n.3)</b> | <b>Range</b>    | 0 ÷ 65000   | 0.00 ÷ 650.00 |
|   | <b>Default</b>  | 0   | 0.00          |
|   | <b>Level</b>    | ENGINEERING   |               |
|   | <b>Address</b>  | 758<br>765<br>772   |               |
|   | <b>Control</b>  | FOC   |               |
|   | <b>Function</b> | <p><b>Kp</b> Proportional coefficient of <b>PI</b> flux regulator for motor n.1 (<b>P165</b> and <b>P172</b> relate to motors 2 and 3).<br/>                     The regulator's structure is as follows:<br/> <math>error = Set\_Point - Measure;</math><br/> <math>integral\_status = integral\_status + error * Ki * Ts;</math><br/> <math>Output = Kp * error + integral\_status;</math><br/>                     where <b>Kp</b> is the proportional coefficient<br/> <b>Ki</b> is the integral coefficient = <math>1/Ti</math> , where <b>Ti</b> is the integral time<br/> <b>Ts</b> is the regulator operating time (ranging from 200 to 400 microseconds based on carrier frequency).</p> |               |

**P159 (P166, P173) Flux Regulator Integral Time**

|   |                 |  |                         |
|---|-----------------|--|-------------------------|
| <b>P159 (Motor n.1)</b><br><b>P166 (Motor n.2)</b><br><b>P173 (Motor n.3)</b> | <b>Range</b>    | 1 ÷ 32000  | 1.0 ÷ 32000. (Disabled) |
|   | <b>Default</b>  | 33   | 33 ms                   |
|   | <b>Level</b>    | ENGINEERING  |                         |
|   | <b>Address</b>  | 759<br>766<br>773  |                         |
|   | <b>Control</b>  | FOC  |                         |
|   | <b>Function</b> | <p><b>Ti</b> Integral time of flux regulator <b>PI</b> for motor n.1 (<b>P166</b> and <b>P173</b> relate to parameters 2 and 3).<br/>                     The regulator's structure is as follows:<br/> <math>error = Set\_Point - Measure;</math><br/> <math>integral\_status = integral\_status + error * Ki * Ts;</math><br/> <math>Output = Kp * error + integral\_status;</math><br/>                     where <b>Kp</b> is the proportional coefficient<br/> <b>Ki</b> is the integral coefficient = <math>1/Ti</math> , where <b>Ti</b> is the integral time<br/> <b>Ts</b> is the regulator operating time (ranging from 200 to 400 microseconds based on carrier frequency).</p> |                         |



**NOTE**

Parameters P159-P166-P173 are **automatically recomputed and saved** whenever the Rotor Time Constant parameter (**C025**) is changed.

## 20. VTC REGULATORS MENU

### 20.1. Overview



**NOTE** A comprehensive review of the MOTOR CONFIGURATION MENU is recommended.



**NOTE** The VTC Regulators menu may be accessed only if the VTC Control is set up for one of the connected motors (**C010**=1 for motor N.1, **C053**=1 for motor N.2, **C096**=1 for motor N.3).

The sensorless VTC control algorithm is based on the same principles as the FOC algorithm, but instead of using the speed value read from the encoder, it exploits an estimated value of that speed value. Estimation is made possible via a dedicated status observer.

As is the case of the FOC algorithm, **two PI current regulators** are available, which have different gain parameters.

The first regulator adjusts the **torque current (Iq)**, whilst the second regulator adjusts the **flux current (Id)**.

**Torque current Iq** is computed based on the torque setpoint required.

In **Slave Mode** (torque reference), the torque setpoint is required by the external reference; in **Master Mode**, the setpoint is given by the **speed regulator** (see SPEED LOOP AND CURRENT BALANCING MENU) that adjusts the motor speed of rotation.

**Flux current Id** is given by the output of the **flux regulator**, that keeps the motor fluxing correct.

The VTC Regulators menu includes the parameters of the current PI regulators and flux regulators for the VTC Control.

### 20.2. List of Parameters P175h1 to P175w

Table 33: List of Parameters P175a1 to P175w

| Parameter     | FUNCTION  | User Level  | DEFAULT VALUE | MODBUS Address |
|---------------|---|-------------|---------------|----------------|
| <b>P175h1</b> | Low-Frequency Flux Increment Percentage for Motor 1         | ENGINEERING | 0.0 %         | <b>684</b>     |
| <b>P175i1</b> | Minimum Frequency for Motor 1 Flux Increment                | ENGINEERING | 10.0 %        | <b>733</b>     |
| <b>P175j1</b> | Maximum Frequency for Motor 1 Flux Increment                | ENGINEERING | 30.0 %        | <b>734</b>     |
| <b>P175r1</b> | Proportional Gain of Motor 1 Flux Current Controller        | ENGINEERING | 800.0         | <b>686</b>     |
| <b>P175s1</b> | Integral Time Constant of Motor 1 Flux Current Controller   | ENGINEERING | [Disabled]    | <b>639</b>     |
| <b>P175t1</b> | Proportional Gain of Motor 1 Torque Current Controller      | ENGINEERING | 320.0         | <b>640</b>     |
| <b>P175u1</b> | Integral Time Constant of Motor 1 Torque Current Controller | ENGINEERING | 50 ms         | <b>709</b>     |
| <b>P175v1</b> | Proportional Gain of Motor 1 Flux Controller                | ENGINEERING | 50.0          | <b>617</b>     |
| <b>P175h2</b> | Low-Frequency Flux Increment Percentage for Motor 2         | ENGINEERING | 0.0 %         | <b>1000</b>    |
| <b>P175i2</b> | Minimum Frequency for Motor 2 Flux Increment                | ENGINEERING | 10.0 %        | <b>1006</b>    |
| <b>P175j2</b> | Maximum Frequency for Motor 2 Flux Increment                | ENGINEERING | 30.0 %        | <b>1027</b>    |
| <b>P175r2</b> | Proportional Gain of Motor 2 Flux Current Controller        | ENGINEERING | 800.0         | <b>637</b>     |
| <b>P175s2</b> | Integral Time Constant of Motor 2 Flux Current Controller   | ENGINEERING | [Disabled]    | <b>638</b>     |
| <b>P175t2</b> | Proportional Gain of Motor 2 Torque Current Controller      | ENGINEERING | 320.0         | <b>641</b>     |
| <b>P175u2</b> | Integral Time Constant of Motor 2 Torque Current Controller | ENGINEERING | 50 ms         | <b>732</b>     |
| <b>P175v2</b> | Proportional Gain of Motor 2 Flux Controller                | ENGINEERING | 50.0          | <b>757</b>     |
| <b>P175h3</b> | Low-Frequency Flux Increment Percentage for Motor 3         | ENGINEERING | 0.0 %         | <b>1005</b>    |
| <b>P175i3</b> | Minimum Frequency for Motor 3 Flux Increment                | ENGINEERING | 10.0 %        | <b>1007</b>    |
| <b>P175j3</b> | Maximum Frequency for Motor 3 Flux Increment                | ENGINEERING | 30.0 %        | <b>1049</b>    |
| <b>P175r3</b> | Proportional Gain of Motor 3 Flux Current Controller        | ENGINEERING | 800.0         | <b>760</b>     |
| <b>P175s3</b> | Integral Time Constant of Motor 3 Flux Current Controller   | ENGINEERING | [Disabled]    | <b>764</b>     |
| <b>P175t3</b> | Proportional Gain of Motor 3 Torque Current Controller      | ENGINEERING | 320.0         | <b>767</b>     |
| <b>P175u3</b> | Integral Time Constant of Motor 3 Torque Current Controller | ENGINEERING | 50 ms         | <b>768</b>     |
| <b>P175v3</b> | Proportional Gain of Motor 3 Flux Controller                | ENGINEERING | 50.0          | <b>771</b>     |
| <b>P175k</b>  | Extra-flux Percentage                                       | ENGINEERING | 110.0 %       | <b>727</b>     |
| <b>P175l</b>  | Minimum Flux Percentage                                     | ENGINEERING | 10.0 %        | <b>742</b>     |

| Parameter | FUNCTION                                  | User Level  | DEFAULT VALUE | MODBUS Address |
|-----------|---|-------------|---------------|----------------|
| P175o     | Filter Time Constant of Flux Rate Limiter | ENGINEERING | 300 ms        | 737            |
| P175p     | Defluxing Time Constant                   | ENGINEERING | 250 ms        | 747            |
| P175w     | Type of Control at Stop with Start Open   | ENGINEERING | Speed         | 611            |

**P175h1 (P175h2, P175h3) Low-Frequency Flux Increment Percentage for Motor 1 (2,3)**

|   |          |   |               |
|---|----------|---|---------------|
| P175h1 (Mot1)<br>P175h2 (Mot2)<br>P175h3 (Mot3) | Range    | 0 ÷ 1000  | 0.0 ÷ 100.0 % |
|   | Default  | 0   | 0.0 %         |
|   | Level    | ENGINEERING   |               |
|   | Address  | 684, 1000, 1005   |               |
|   | Control  | VTC   |               |
|   | Function | Percentage of the flux increment at low frequency. Indicates the increment percentage of the motor flux, in respect of its nominal value, adopted up to the frequency value displayed in P175i1. The flux increment is dropped to 0 linearly with the frequency (flux equal to the nominal value) at the frequency value displayed in P175j1. |               |

**P175i1 (P175i2, P175i3) Minimum Frequency for Motor 1 (2,3) Flux Increment**

|   |          |   |               |
|---|----------|---|---------------|
| P175i1 (Mot1)<br>P175i2 (Mot2)<br>P175i3 (Mot3) | Range    | 0 ÷ 1000  | 0.0 ÷ 100.0 % |
|   | Default  | 100   | 10.0 %        |
|   | Level    | ENGINEERING   |               |
|   | Address  | 733, 1006, 1007   |               |
|   | Control  | VTC   |               |
|   | Function | Minimum frequency of the interpolation for the flux increment at low frequency. Indicates the frequency up to which a flux increment equal to the value set in parameter P175h1 is adopted. See the description for P175h1. |               |

**P175j1 (P175j2, P175j3) Maximum Frequency for Motor 1 (2,3) Flux Increment**

|   |          |  |               |
|---|----------|--|---------------|
| P175j1 (Mot1)<br>P175j2 (Mot2)<br>P175j3 (Mot3) | Range    | 0 ÷ 1000   | 0.0 ÷ 100.0 % |
|   | Default  | 300  | 30.0 %        |
|   | Level    | ENGINEERING  |               |
|   | Address  | 734, 1027, 1049  |               |
|   | Control  | VTC  |               |
|   | Function | Maximum frequency of the interpolation for the flux increment at low frequency. Indicates the frequency from which the nominal value of the flux is adopted. See the description for P175h1. |               |

**P175r1 (P175r2, P175r3) Proportional Gain of Motor 1 (2,3) Flux Current Controller**

|   |          |   |                |
|---|----------|---|----------------|
| P175r1 (Mot1)<br>P175r2 (Mot2)<br>P175r3 (Mot3) | Range    | 0 ÷ 32000   | 0.000 ÷ 3200.0 |
|   | Default  | 8000  | 800.0          |
|   | Level    | ENGINEERING   |                |
|   | Address  | 686, 637, 760   |                |
|   | Control  | VTC   |                |
|   | Function | Proportional gain of the flux current control (d axis). |                |

**P175s1 (P175s2, P175s3) Integral Time Constant of Motor 1 (2, 3) Flux Current Controller**

|  |                 |  |                         |
|--|-----------------|--|-------------------------|
| <b>P175s1 (Mot1)<br/>P175s2 (Mot2)<br/>P175s3 (Mot3)</b> | <b>Range</b>    | 1 ÷ 32000  | 1 ÷ 32000 ms [Disabled] |
|  | <b>Default</b>  | 32000  | Disabled                |
|  | <b>Level</b>    | ENGINEERING  |                         |
|  | <b>Address</b>  | 639, 638, 764  |                         |
|  | <b>Control</b>  | VTC  |                         |
|  | <b>Function</b> | Integral time constant of the flux current control (d axis). |                         |

**P175t1 (P175t2, P175t3) Proportional Gain of Motor 1 (2,3) Torque Current Controller**

|  |                 |   |                |
|--|-----------------|---|----------------|
| <b>P175t1 (Mot1)<br/>P175t2 (Mot2)<br/>P175t3 (Mot3)</b> | <b>Range</b>    | 0 ÷ 32000   | 0.000 ÷ 3200.0 |
|  | <b>Default</b>  | 3200  | 320.0          |
|  | <b>Level</b>    | ENGINEERING   |                |
|  | <b>Address</b>  | 640, 641, 767   |                |
|  | <b>Control</b>  | VTC   |                |
|  | <b>Function</b> | Proportional gain of the torque current control (q axis). |                |

**P175u1 (P175u2, P175u3) Integral Time Constant of Motor 1 (2,3) Torque Current Controller**

|  |                 |  |                         |
|--|-----------------|--|-------------------------|
| <b>P175u1 (Mot1)<br/>P175u2 (Mot2)<br/>P175u3 (Mot3)</b> | <b>Range</b>    | 1 ÷ 32000  | 1 ÷ 32000 ms [Disabled] |
|  | <b>Default</b>  | 50   | 50 ms                   |
|  | <b>Level</b>    | ENGINEERING  |                         |
|  | <b>Address</b>  | 709, 732, 768  |                         |
|  | <b>Control</b>  | VTC  |                         |
|  | <b>Function</b> | Integral time constant of the torque current control (q axis). |                         |

**P175v1 (P175v2, P175v3) Proportional Gain of Motor 1 (2,3) Flux Controller**

|  |                 |   |                |
|--|-----------------|---|----------------|
| <b>P175v1 (Mot1)<br/>P175v2 (Mot2)<br/>P175v3 (Mot3)</b> | <b>Range</b>    | 1 ÷ 32000                                 | 0.000 ÷ 3200.0 |
|  | <b>Default</b>  | 500                                       | 50.0           |
|  | <b>Level</b>    | ENGINEERING                               |                |
|  | <b>Address</b>  | 617, 757, 771                             |                |
|  | <b>Control</b>  | VTC                                       |                |
|  | <b>Function</b> | Proportional gain of the flux controller. |                |

**NOTE**

Parameters **P175r1**, **P175s1**, **P175t1**, **P175u1**, **P175v1** are automatically computed and saved by performing the current loop autotune procedure **I074 = [6: VTC Auto no rotation (current)]**.

**P175k Extra-flux Percentage**

|              |                 |  |                 |
|--------------|-----------------|--|-----------------|
| <b>P175k</b> | <b>Range</b>    | 1000 ÷ 1500  | 100.0 ÷ 150.0 % |
|              | <b>Default</b>  | 1100   | 110.0 %         |
|              | <b>Level</b>    | ENGINEERING  |                 |
|              | <b>Address</b>  | 727  |                 |
|              | <b>Control</b>  | VTC  |                 |
|              | <b>Function</b> | Extra-flux percentage, in respect to the nominal flux, used when decelerating to increase the motor resistor losses and to dissipate the incoming energy produced by the motor in order to limit the DC bus voltage. |                 |

**P175l Minimum Flux**

|              |                 |  |               |
|--------------|-----------------|--|---------------|
| <b>P175l</b> | <b>Range</b>    | 0 ÷ 1000   | 0.0 ÷ 100.0 % |
|              | <b>Default</b>  | 100  | 10.0 %        |
|              | <b>Level</b>    | ENGINEERING  |               |
|              | <b>Address</b>  | 742  |               |
|              | <b>Control</b>  | VTC  |               |
|              | <b>Function</b> | Minimum reference flux expressed as a percentage with respect of the nominal flux. |               |

**P175o Filter Time Constant of Flux Rate Limiter**

|              |                 |  |              |
|--------------|-----------------|--|--------------|
| <b>P175o</b> | <b>Range</b>    | 1 ÷ 32000  | 1 ÷ 32000 ms |
|              | <b>Default</b>  | 300  | 300 ms       |
|              | <b>Level</b>    | ENGINEERING  |              |
|              | <b>Address</b>  | 737  |              |
|              | <b>Control</b>  | VTC  |              |
|              | <b>Function</b> | Time constant of the filter adopted in the fluxing rate limiter. |              |

**P175p Defluxing Time Constant**

|              |                 |   |              |
|--------------|-----------------|---|--------------|
| <b>P175p</b> | <b>Range</b>    | 1 ÷ 32000                                     | 1 ÷ 32000 ms |
|              | <b>Default</b>  | 250   | 250 ms       |
|              | <b>Level</b>    | ENGINEERING                                   |              |
|              | <b>Address</b>  | 747   |              |
|              | <b>Control</b>  | VTC   |              |
|              | <b>Function</b> | Time constant setting the defluxing dynamics. |              |

**P175w Type of Control at Stop with START Open**

|              |                 |  |                             |
|--------------|-----------------|--|-----------------------------|
| <b>P175w</b> | <b>Range</b>    | 0 ÷ 1  | 0: Speed<br>1: Fluxing only |
|              | <b>Default</b>  | 0  | 0: Speed                    |
|              | <b>Level</b>    | ENGINEERING  |                             |
|              | <b>Address</b>  | 611  |                             |
|              | <b>Control</b>  | VTC  |                             |
|              | <b>Function</b> | Selects the type of control when the motor is stopped and the START input is open.<br>The speed control is disabled if this parameter is set to 1: [Fluxing only] when the START input is open and the motor is stopped. |                             |

## 21. ANALOG AND FREQUENCY OUTPUTS MENU

### 21.1. Overview

---

**NOTE**

Please refer to the Sinus Penta's Installation Guide for the hardware description of the analog output and the frequency output or for the configuration of the dip-switches for voltage/current outputs.

**NOTE**

MDO1 digital output is used when the frequency output is enabled (**P200** other than Disabled). Any configuration set in the DIGITAL OUTPUTS MENU will have no effect.

The Sinus Penta drive allows configuring three programmable analog outputs as voltage outputs or current outputs, as well as one frequency output.

#### 21.1.1. FACTORY-SETTING OF THE ANALOG OUTPUTS

Analog outputs are factory set to voltage values ranging from  $\pm 10V$  and the following variables are selected:

| TERMINALS | OUTPUTS | SELECTED VARIABLE                            | OUTPUT RANGE | MIN. VALUE | MAX. VALUE  |
|-----------|---------|--|--------------|------------|-------------|
| 10        | AO1     | Speed (speed of the connected motor)         | $\pm 10V$    | -1500      | 1500        |
| 11        | AO2     | Speed Ref. (speed reference at constant rpm) | $\pm 10V$    | -1500      | 1500        |
| 12        | AO3     | Current of the connected motor               | $\pm 10V$    | 0          | $I_{max}^*$ |

\* Depending on the inverter size.

#### 21.1.2. ANALOG OUTPUTS

As per the analog outputs, the ANALOG AND FREQUENCY OUTPUTS MENU allows selecting the variable to be represented, its range, its acquisition mode ( $\pm$  or as an absolute value), the type of analog output (voltage/current) and the output values corresponding to the min. value and the max. value of the selected variable. An offset value and a filtering function may also be applied to the analog outputs. For the frequency output, this menu contains the parameters for the selection of the represented variable, its acquisition mode ( $\pm$  or as an absolute value), its min. value and max. value and the corresponding output frequency value, and a filtering function. The figure below shows the typical structure of the analog outputs; in particular, AO1 analog output and its parameter set are illustrated.

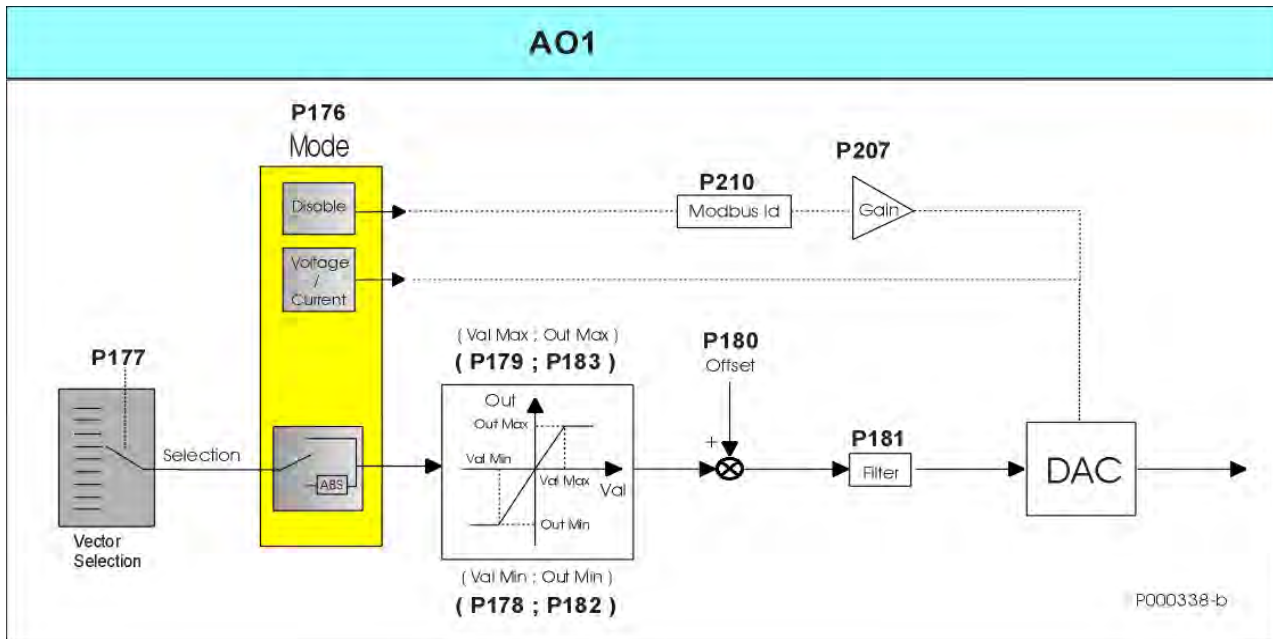

Figure 15: Typical structure of the Analog Outputs

- **Vector Selection** Selects the variable to be represented through the digital analog converter (DAC). **P177** is the selection parameter for AO1 analog output and **P185** and **P193** for AO2 and AO3 respectively.
- **Mode** Sets the acquisition mode of the selected variable ( $\pm$  or as an absolute value) and the type (voltage/current) for the analog output. If Mode = **Disable**, a different operating mode is activated for the analog output for which the represented variable is determined by the MODBUS address set in Address and the gain value set in Gain is applied:  
**P176** (Mode), **P207** (Gain), **P210** (Address) for AO1;  
**P184** (Mode), **P208** (Gain), **P211** (Address) for AO2;  
**P192** (Mode), **P209** (Gain), **P212** (Address) for AO3.
- **(Val Min; Out Min)** Defines the minimum saturation value of the variable to be represented and the corresponding value to be assigned to the analog output. For values equal to or lower than Val Min, Out Min will be assigned to the selected analog output. For analog outputs AO1, AO2, and AO3, the following parameters will be used: **(P178; P182)**, **(P186; P190)** and **(P194; P198)** for values **(Val Min; Out Min)**.
- **(Val Max; Out Max)** Defines the maximum saturation value of the variable to be represented and the corresponding value to be assigned to the analog output. For values equal to or higher than Val Max, Out Max will be assigned to the selected analog output. For analog outputs AO1, AO2, and AO3, the following parameters will be used: **(P179; P183)**, **(P187; P191)** and **(P195; P199)** for values **(Val Max; Out Max)**.
- **Offset** Defines the offset value applied to the analog output. Offset is set in parameter **P180** for AO1 analog output, in parameters **P188**, **P196** for AO2 and AO3 respectively.
- **Filter** Defines the filter time constant applied to the analog output. The filter time constant is set in parameter **P181** for AO1 analog output, in parameters **P189**, **P197** for AO2 and AO3 respectively.

### 21.1.3. FREQUENCY OUTPUT

When programming the frequency output, the setting of MDO1 in the DIGITAL OUTPUTS MENU is disabled. The figure below illustrates the structure of the frequency output. Parameterization is similar to the one used for the analog outputs.

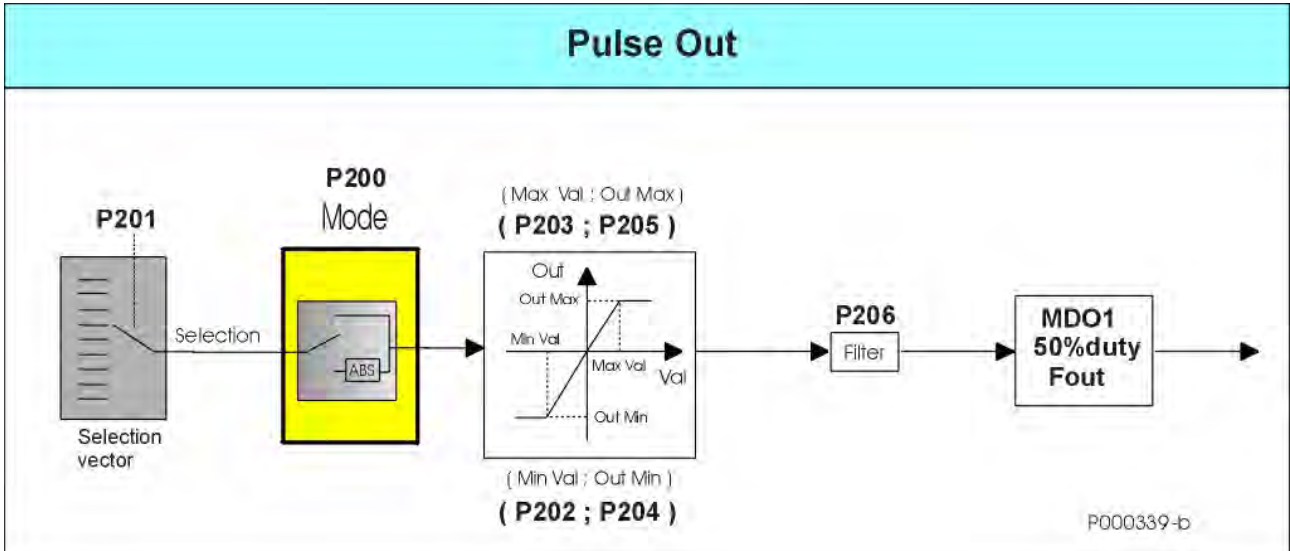

Figure 16: Structure of the Frequency Output

## 21.2. Variables

This section covers the variables that can be represented for the analog and frequency outputs.

**Table 34: Variables to be selected for the Analog and Frequency Outputs**

| SELECTION CODE   |                  |   |
|------------------|------------------|---|
| Selection Value  | Full-scale Value | Description                                   |
| 0: Disable       |                  | Disabled output                               |
| 1: Speed         | 10000 rpm        | Speed of the connected motor                  |
| 2: Speed Ref.    | 10000 rpm        | Speed reference at constant speed             |
| 3: Ramp Out      | 10000 rpm        | "Ramped" speed reference                      |
| 4: Mot. Freq.    | 1000.0 Hz        | Frequency produced by the drive               |
| 5: Mot. Curr.    | 5000.0 A         | Current RMS                                   |
| 6: Out Volt      | 2000.0 V         | Output voltage RMS                            |
| 7: OutPower      | 5000.0 kW        | Output power                                  |
| 8: DC Vbus       | 2000.0 V         | DC-link voltage                               |
| 9: Torq.Ref      | 10000%           | Torque reference at constant speed            |
| 10: Torq.Dem     | 10000 Nm         | Demanded torque (Nm)                          |
| 11: Torq.Out     | 10000%           | Evaluation of the torque output               |
| 12: Torq.Lim     | 10000%           | Setpoint of the torque limit                  |
| 13: PID Ref%     | 100.00%          | PID reference at constant speed               |
| 14: PID RMP%     | 100.00%          | "Ramped" PID reference                        |
| 15: PID Err%     | 100.00%          | Error between PID reference and feedback      |
| 16: PID Fbk%     | 100.00%          | Feedback to the PID                           |
| 17: PID Out%     | 100.00%          | Output of the PID                             |
| 18: REF          | 100.00%          | Analog input REF                              |
| 19: AIN1         | 100.00%          | Analog input AIN1                             |
| 20: AIN2/PTC     | 100.00%          | Analog input AIN2                             |
| 21: Enc. In      | 10000 rpm        | Speed read by the encoder used as a reference |
| 22: Pulseln      | 100.00 kHz       | Frequency input                               |
| 23: Flux Ref     | 1.0000 Wb        | Flux reference at constant speed              |
| 24: Flux         | 1.0000 Wb        | Current flux reference                        |
| 25: iq ref.      | 5000.0 A         | Current reference in axis q                   |
| 26: id ref.      | 5000.0 A         | Current reference in axis d                   |
| 27: iq           | 5000.0 A         | Current measure in axis q                     |
| 28: id           | 5000.0 A         | Current measure in axis d                     |
| 29: Volt.Vq      | 2000.0 V         | Voltage in axis q                             |
| 30: Volt Vd      | 2000.0 V         | Voltage in axis d                             |
| 31: Cosine       | 100.00%          | Cosine waveform                               |
| 32: Sine         | 100.00%          | Sine waveform                                 |
| 33: Angle        | 1.0000 rad       | Electric angle of delivered Vu                |
| 34: +10V         | 10.000 V         | Voltage level +10V                            |
| 35: -10V         | 10.000 V         | Voltage level -10V                            |
| 36: Flux Current | 5000.0 A         | Flux Current                                  |
| 37: Sqr Wave     | 100.00%          | Square wave                                   |
| 38: Saw Wave     | 100.00%          | Saw wave                                      |
| 39: Hts Temp.    | 100.00 °C        | Temperature of the heatsink                   |
| 40: Amb Temp.    | 100.00 °C        | Ambient temperature                           |
| 41+49: RESERVED  |                  | RESERVED                                      |
| 50: PT100_1      | 100.00%          | PT100 Channel 1                               |
| 51: PT100_2      | 100.00%          | PT100 Channel 2                               |
| 52: PT100_3      | 100.00%          | PT100 Channel 3                               |
| 53: PT100_4      | 100.00%          | PT100 Channel 4                               |
| 54: I2t%         | 100.00%          | Motor thermal capacity                        |
| 55: XAIN4        | 100.00%          | XAIN4 Analog input                            |
| 56: XAIN5        | 100.00%          | XAIN5 Analog input                            |
| 57: OT Count     | 100000h          | Maintenance Operation Time Counter            |
| 58: ST Count     | 100000h          | Maintenance Supply Time Counter               |

|                       |         |  |
|-----------------------|---------|--|
| 59: PID2 Reference    | 100.00% | Reference at constant speed of PID2          |
| 60: PID2 Set Point    | 100.00% | “Ramped” reference of PID2                   |
| 61: PID2 Feedback     | 100.00% | PID2 Feedback                                |
| 62: PID2 Error        | 100.00% | Error between reference and feedback of PID2 |
| 63: PID2 Out          | 100.00% | Output of PID2                               |
| 64: Torque Demand     | 100.00% | Torque demand (value percent)                |
| 65: Actual Current Iv | 5000A   | Output Current Iv                            |
| 66: RESERVED          |         | RESERVED                                     |
| 67: RESERVED          |         | RESERVED                                     |
| 68: RESERVED          |         | RESERVED                                     |
| 69: RESERVED          |         | RESERVED                                     |

Table 34 provides a brief description of each variable and its full-scale value used to set the minimum and maximum value.

### 21.2.1. OPERATING MODE OF ANALOG AND FREQUENCY OUTPUTS

This section covers the different representation modes to be selected for the analog and frequency outputs.

The following modes can be used for analog outputs:

- 0: Disabled** Disabled analog output (enables a RESERVED operating mode).
- 1: ± 10V** The analog output is set as a voltage output and the possible min. and max. output values range from +/– 10V. The selected variable has a positive or negative sign.
- 2: 0÷10V** The analog output is set as a voltage output and the possible min. and max. output values range from 0 to 10V. The selected variable has a positive or negative sign.
- 3: 0÷20mA** The analog output is set as a current output and the possible min. and max. output values range from 0 to 20mA. The selected variable has a positive or negative sign.
- 4: 4÷20mA** The analog output is set as a current output and the possible min. and max. output values range from 4 to 20mA. The selected variable has a positive or negative sign.
- 5: ABS 0÷10V** As 0÷10V output mode, but the selected variable is considered as an absolute value.
- 6: ABS 0÷20mA** As 0÷20mA output mode, but the selected variable is considered as an absolute value.
- 7: ABS 4÷20mA** As 4÷20mA output mode, but the selected variable is considered as an absolute value.



**NOTE** Always check the min. and max. values of the outputs programmed in the relevant parameters.

Three operating modes can be selected for the **Frequency Output**:

- 0: Disabled** The output frequency is disabled.
- 1: Pulse Out** MDO1 Digital Output is programmed as a frequency output. The selected variable has a positive or negative sign.
- 2: ABS Pulse Out** As Pulse Out, but the selected variable is considered as an absolute value.



**NOTE** When **P200** is not set to DISABLE, MDO1digital output is used as a frequency output and any MDO1 settings in the DIGITAL OUTPUTS MENU are ignored.

### 21.2.2. ANALOG OUTPUT PROGRAMMING EXAMPLES

This section contains a description of operating examples of the analog outputs obtained with different programming modes.

**Example 1:**

**Table 35: Programming AO1 (0÷ 10V)**

| Parameterization of AO1 Analog Output |          |  |
|---------------------------------------|----------|--|
| Parameter                             | Value    | Description                                  |
| P176                                  | 0÷10V    | AO1 Analog output                            |
| P177                                  | 1: Speed | Selected variable for AO1 analog output      |
| P178                                  | -500 rpm | Min. value of AO1 selected variable          |
| P179                                  | +500 rpm | Max. value of AO1 selected variable          |
| P180                                  | 0.000 V  | AO1 Analog output offset                     |
| P181                                  | 0 ms     | Filter for AO1 analog output                 |
| P182                                  | 0.0 V    | Min. AO1 output value with reference to P178 |
| P183                                  | 10.0 V   | Max. AO1 output value with reference to P179 |

**Figure 17: Curve (voltage; speed) implemented by AO1 (Example 1)**

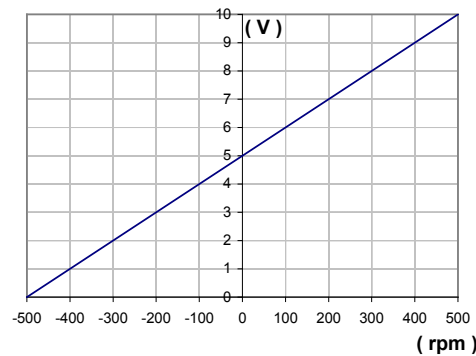

**Example 2:**

**Table 36: Programming AO1 (0 ÷ 10V)**

| Parameterization of Analog Output AO1 |           |  |
|---------------------------------------|-----------|--|
| Parameter                             | Value     | Description                                  |
| P176                                  | ABS 0÷10V | AO1 Analog output                            |
| P177                                  | 1: Speed  | Selected variable for AO1 analog output      |
| P178                                  | 0 rpm     | Min. value of AO1 selected variable          |
| P179                                  | +500 rpm  | Max. value of AO1 selected variable          |
| P180                                  | 0.000 V   | AO1 Analog output offset                     |
| P181                                  | 0 ms      | Filter for AO1 analog output                 |
| P182                                  | 0.0 V     | Min. AO1 output value with reference to P178 |
| P183                                  | 10.0 V    | Max. AO1 output value with reference to P179 |

Figure 18: Curve (voltage; speed) implemented by AO1 (Example 2)

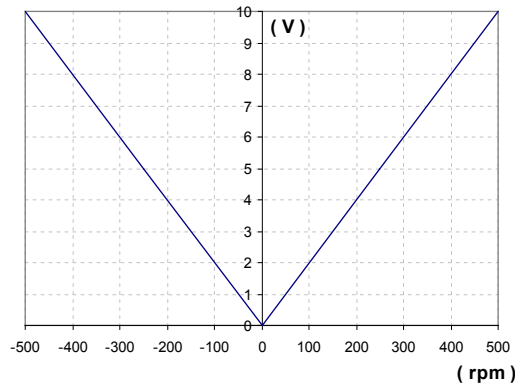

Example 3:

Table 37: Programming AO1 (ABS 0 ÷ 10V)

| Parameterization of Analog Output AO1 |           |  |
|---------------------------------------|-----------|--|
| Parameter                             | Value     | Description                                  |
| P176                                  | ABS 0÷10V | AO1 Analog output                            |
| P177                                  | 1: Speed  | Selected variable for AO1 analog output      |
| P178                                  | -500 rpm  | Min. value of AO1 selected variable          |
| P179                                  | +500 rpm  | Max. value of AO1 selected variable          |
| P180                                  | 0.000 V   | AO1 Analog output offset                     |
| P181                                  | 0 ms      | Filter for AO1 analog output                 |
| P182                                  | 0.0 V     | Min. AO1 output value with reference to P178 |
| P183                                  | 10.0 V    | Max. AO1 output value with reference to P179 |

Figure 19: Curve (voltage; speed) implemented by AO1 (Example 3)

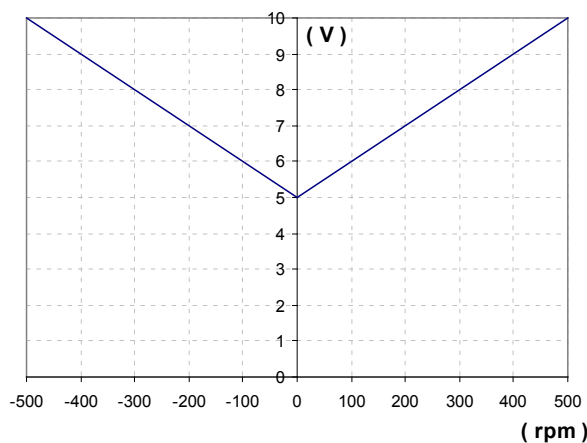

**NOTE**

The programming mode above would imply a straight line passing through (-500rpm; 0V) and (+500rpm; 10V), but based on the selected mode and considering the variable as an absolute value, the min. point for output AO1 will be (0 rpm; 5 V).

Example 4:

Table 38: Programming AO1 (ABS 0 ÷ 10V)

| Parameterization of Analog Output AO1 |           |  |
|---------------------------------------|-----------|--|
| Parameter                             | Value     | Description                                  |
| P176                                  | ABS 0÷10V | AO1 Analog output                            |
| P177                                  | 1: Speed  | Selected variable for AO1 analog output      |
| P178                                  | +100 rpm  | Min. value of AO1 selected variable          |
| P179                                  | +500 rpm  | Max. value of AO1 selected variable          |
| P180                                  | 0.000 V   | AO1 Analog output offset                     |
| P181                                  | 0 ms      | Filter for AO1 analog output                 |
| P182                                  | 0.0 V     | Min. AO1 output value with reference to P178 |
| P183                                  | 10.0 V    | Max. AO1 output value with reference to P179 |

Figure 20: Curve (voltage; speed) implemented by AO1 (Example 4)

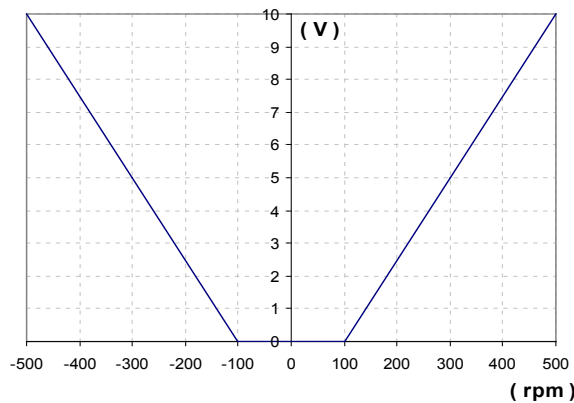

Example 5:

Table 39: Programming AO1 (± 10V)

| Parameterization of Analog Output AO1 |          |  |
|---------------------------------------|----------|--|
| Parameter                             | Value    | Description                                  |
| P176                                  | ±10V     | AO1 Analog output                            |
| P177                                  | 1: Speed | Selected variable for AO1 analog output      |
| P178                                  | +500 rpm | Min. value of AO1 selected variable          |
| P179                                  | -500 rpm | Max. value of AO1 selected variable          |
| P180                                  | 0.000 V  | AO1 Analog output offset                     |
| P181                                  | 0 ms     | Filter for AO1 analog output                 |
| P182                                  | -10.0 V  | Min. AO1 output value with reference to P178 |
| P183                                  | +10.0 V  | Max. AO1 output value with reference to P179 |

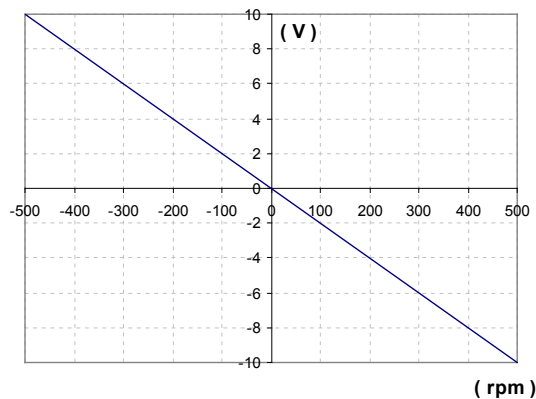

Figure 21: Curve (voltage; speed) implemented by AO1 (Example 5)

## 21.3. List of Parameters P176 to P215

Table 40: List of parameters P176 to P215

| Param.      | Function   | User Level  | DEFAULT VALUES                     | Modbus Address |
|-------------|--|-------------|------------------------------------|----------------|
| <b>P176</b> | AO1 analog output                                    | ADVANCED    | 1: $\pm 10V$                       | 776            |
| <b>P177</b> | Selected variable for AO1 analog output              | ADVANCED    | 1: Motor speed                     | 777            |
| <b>P178</b> | Min. value of AO1 selected variable                  | ADVANCED    | -1500 rpm                          | 778            |
| <b>P179</b> | Max. value of AO1 selected variable                  | ADVANCED    | +1500 rpm                          | 779            |
| <b>P180</b> | AO1 Analog output offset                             | ADVANCED    | 0.000 V                            | 780            |
| <b>P181</b> | Filter for AO1 analog output                         | ADVANCED    | 0 ms                               | 781            |
| <b>P182</b> | Min. AO1 output value with reference to <b>P178</b>  | ADVANCED    | -10.0 V                            | 782            |
| <b>P183</b> | Max. AO1 output value with reference to <b>P179</b>  | ADVANCED    | +10.0V                             | 783            |
| <b>P184</b> | AO2 analog output                                    | ADVANCED    | 1: $\pm 10V$                       | 784            |
| <b>P185</b> | Selected variable for AO2 analog output              | ADVANCED    | 2: Speed reference at constant rpm | 785            |
| <b>P186</b> | Min. value of AO2 selected variable                  | ADVANCED    | -1500 rpm                          | 786            |
| <b>P187</b> | Max. value of AO2 selected variable                  | ADVANCED    | +1500 rpm                          | 787            |
| <b>P188</b> | AO2 Analog output offset                             | ADVANCED    | 0.000 V                            | 788            |
| <b>P189</b> | Filter for AO2 analog output                         | ADVANCED    | 0 ms                               | 789            |
| <b>P190</b> | Min. AO2 output value with reference to <b>P186</b>  | ADVANCED    | -10.0 V                            | 790            |
| <b>P191</b> | Max. AO2 output value with reference to <b>P187</b>  | ADVANCED    | +10.0V                             | 791            |
| <b>P192</b> | AO3 analog output                                    | ADVANCED    | 2: 0+10V                           | 792            |
| <b>P193</b> | Selected variable for AO3 analog output              | ADVANCED    | 5: Output current                  | 793            |
| <b>P194</b> | Min. value of AO3 selected variable                  | ADVANCED    | 0 A                                | 794            |
| <b>P195</b> | Max. value of AO3 selected variable                  | ADVANCED    | Inverter I <sub>max</sub>          | 795            |
| <b>P196</b> | AO3 Analog output offset                             | ADVANCED    | 0.000 V                            | 796            |
| <b>P197</b> | Filter for AO3 analog output                         | ADVANCED    | 0 ms                               | 797            |
| <b>P198</b> | Min. AO3 output value with reference to <b>P194</b>  | ADVANCED    | 0.0 V                              | 798            |
| <b>P199</b> | Max. AO3 output value with reference to <b>P195</b>  | ADVANCED    | +10.0V                             | 799            |
| <b>P200</b> | FOUT output in [MDO1] frequency                      | ADVANCED    | 0: Disabled                        | 800            |
| <b>P201</b> | Selected variable for FOUT frequency output          | ADVANCED    | 1: Motor speed                     | 801            |
| <b>P202</b> | Min. FOUT value of selected variable                 | ADVANCED    | 0                                  | 802            |
| <b>P203</b> | Max. FOUT value of selected variable                 | ADVANCED    | 0                                  | 803            |
| <b>P204</b> | Min. FOUT output value with reference to <b>P202</b> | ADVANCED    | 10.00 kHz                          | 804            |
| <b>P205</b> | Max. FOUT output value with reference to <b>P203</b> | ADVANCED    | 100.00 kHz                         | 805            |
| <b>P206</b> | Filter for FOUT frequency output                     | ADVANCED    | 0 ms                               | 806            |
| <b>P207</b> | AO1: Gain  | ADVANCED    | RESERVED                           | 807            |
| <b>P208</b> | AO2: Gain  | ADVANCED    |                                    | 808            |
| <b>P209</b> | AO3: Gain  | ADVANCED    |                                    | 809            |
| <b>P210</b> | AO1: Variable MODBUS address                         | ADVANCED    |                                    | 810            |
| <b>P211</b> | AO2: Variable MODBUS address                         | ADVANCED    |                                    | 811            |
| <b>P212</b> | AO3: Variable MODBUS address                         | ADVANCED    |                                    | 812            |
| <b>P213</b> | Amplitude of sinusoidal analog output signal         | ENGINEERING | 100.0%                             | 813            |
| <b>P214</b> | Frequency of sinusoidal analog output signal         | ENGINEERING | 1.00 Hz                            | 814            |
| <b>P215</b> | Frequency of saw wave analog output signal           | ENGINEERING | 1.00 Hz                            | 815            |

**P176 AO1 Analog Output**

|             |                 |  |   |
|-------------|-----------------|--|---|
| <b>P176</b> | <b>Range</b>    | 0 ÷ 7  | 0: Disabled,<br>1: ± 10V,<br>2: 0 ÷ 10V,<br>3: 0 ÷ 20mA,<br>4: 4 ÷ 20mA,<br>5: ABS 0 ÷ 10V,<br>6: ABS 0 ÷ 20mA,<br>7: ABS 4 ÷ 20mA. |
|             | <b>Default</b>  | 1  | 1: ± 10V  |
|             | <b>Level</b>    | ADVANCED   |   |
|             | <b>Address</b>  | 776  |   |
|             | <b>Function</b> | Selects the operating mode of AO1 analog output. |   |

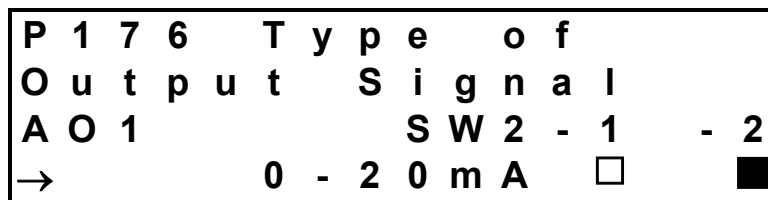

In the example above, AO1 is set as a current input. Contact 1 of SW2 dip-switch is open, contact 2 is closed.



**NOTE**

Analog outputs are set as voltage outputs by default. To set them as current outputs, see the DIP-switch configuration and follow the instructions displayed on the keypad, or refer to the Sinus Penta's Installation Guide.

**P177 Selected Variable for AO1 Analog Output**

|             |                 |   |              |
|-------------|-----------------|---|--------------|
| <b>P177</b> | <b>Range</b>    | 0 ÷ 69  | See Table 34 |
|             | <b>Default</b>  | 1   | Motor speed  |
|             | <b>Level</b>    | ADVANCED  |              |
|             | <b>Address</b>  | 777   |              |
|             | <b>Function</b> | Selects the variable to be allocated to AO1 digital output. |              |

**P178 Min. value of AO1 Selected Variable**

|             |                 |   |  |
|-------------|-----------------|---|--|
| <b>P178</b> | <b>Range</b>    | -32000 ÷ +32000<br>Depending on the value selected in <b>P177</b>   | - 320.00% ÷ + 320.00 % of the full-scale value<br>See Table 34 |
|             | <b>Default</b>  | -1500   | -15.00% of 10000 rpm = -1500 rpm                               |
|             | <b>Level</b>    | ADVANCED  |  |
|             | <b>Address</b>  | 778   |  |
|             | <b>Function</b> | Minimum value of the variable selected via <b>P177</b> , corresponding to the min. output value of AO1 set in <b>P182</b> . |  |

**P179 Max. value of AO1 Selected Variable**

|             |                 |   |  |
|-------------|-----------------|---|--|
| <b>P179</b> | <b>Range</b>    | -32000 ÷ +32000<br>Depending on the value selected in <b>P177</b>   | - 320.00% ÷ + 320.00 % of the full-scale value<br>See Table 34 |
|             | <b>Default</b>  | +1500   | +15.00% of 10000 rpm = +1500 rpm                               |
|             | <b>Level</b>    | ADVANCED  |  |
|             | <b>Address</b>  | 779   |  |
|             | <b>Function</b> | Maximum value of the variable selected via <b>P177</b> , corresponding to the max. output value of AO1 set in <b>P183</b> . |  |

**P180 AO1 Analog Output Offset**

|             |                 |   |                 |
|-------------|-----------------|---|-----------------|
| <b>P180</b> | <b>Range</b>    | -9999 ÷ +9999<br>Depending on the value selected in <b>P176</b> | -9.999 ÷ +9.999 |
|             | <b>Default</b>  | 0   | 0.000 V         |
|             | <b>Level</b>    | ADVANCED  |                 |
|             | <b>Address</b>  | 780   |                 |
|             | <b>Function</b> | Offset value applied to AO1 analog output.                      |                 |

**P181 Filter for AO1 Analog Output**

|             |                 |   |                     |
|-------------|-----------------|---|---------------------|
| <b>P181</b> | <b>Range</b>    | 0 ÷ 65000   | 0.000 ÷ 65.000 sec. |
|             | <b>Default</b>  | 0   | 0.000 sec.          |
|             | <b>Level</b>    | ADVANCED  |                     |
|             | <b>Address</b>  | 781   |                     |
|             | <b>Function</b> | Value of the filter time constant applied to AO1 analog output. |                     |

**P182 Min. AO1 Output Value with Reference to P178**

|             |                 |   |                                     |
|-------------|-----------------|---|-------------------------------------|
| <b>P182</b> | <b>Range</b>    | -100 ÷ +100<br>-200 ÷ +200<br>Depending on the value selected in <b>P176</b>                            | -10.0 ÷ +10.0 V<br>-20.0 ÷ +20.0 mA |
|             | <b>Default</b>  | -100  | -10.0 V                             |
|             | <b>Level</b>    | ADVANCED  |                                     |
|             | <b>Address</b>  | 782   |                                     |
|             | <b>Function</b> | Minimum output value obtained when the minimum value of the variable set in <b>P178</b> is implemented. |                                     |

**P183 Max. AO2 Output Value with Reference to P179**

|             |                 |   |                                     |
|-------------|-----------------|---|-------------------------------------|
| <b>P183</b> | <b>Range</b>    | -100 ÷ +100<br>-200 ÷ +200<br>Depending on the value selected in <b>P176</b>                            | -10.0 ÷ +10.0 V<br>-20.0 ÷ +20.0 mA |
|             | <b>Default</b>  | +100  | +10.0 V                             |
|             | <b>Level</b>    | ADVANCED  |                                     |
|             | <b>Address</b>  | 783   |                                     |
|             | <b>Function</b> | Maximum output value obtained when the maximum value of the variable set in <b>P179</b> is implemented. |                                     |

**P184 AO2 Analog Output**

|             |                 |  |   |
|-------------|-----------------|--|---|
| <b>P184</b> | <b>Range</b>    | 0 ÷ 7  | 0: Disabled,<br>1: ± 10V,<br>2: 0 ÷ 10V,<br>3: 0 ÷ 20mA,<br>4: 4 ÷ 20mA,<br>5: ABS 0 ÷ 10V,<br>6: ABS 0 ÷ 20mA,<br>7: ABS 4 ÷ 20mA. |
|             | <b>Default</b>  | 1  | 1: ± 10V  |
|             | <b>Level</b>    | ADVANCED   |   |
|             | <b>Address</b>  | 784  |   |
|             | <b>Function</b> | Selects the operating mode of AO2 analog output. |   |

**NOTE**

Analog outputs are set as voltage outputs by default. To set them as current outputs, see the DIP-switch configuration and follow the instructions displayed on the keypad, or refer to the Sinus Penta's Installation Guide.

**P185 Selected Variable for AO2 Analog Output**

|             |                 |   |                             |
|-------------|-----------------|---|-----------------------------|
| <b>P185</b> | <b>Range</b>    | 0 ÷ 69  | See Table 34                |
|             | <b>Default</b>  | 2   | Reference at constant speed |
|             | <b>Level</b>    | ADVANCED  |                             |
|             | <b>Address</b>  | 785   |                             |
|             | <b>Function</b> | Selects the variable to be allocated to AO2 digital output. |                             |

**P186 Min. Value of AO2 Selected Variable**

|             |                 |   |   |
|-------------|-----------------|---|---|
| <b>P186</b> | <b>Range</b>    | -32000 ÷ +32000<br>Depends on the value selected in <b>P185</b>   | -320.00 % ÷ +320.00 % of the full-scale value<br>See Table 34 |
|             | <b>Default</b>  | -1500   | -1500 rpm   |
|             | <b>Level</b>    | ADVANCED  |   |
|             | <b>Address</b>  | 786   |   |
|             | <b>Function</b> | Minimum value of the variable selected via <b>P185</b> , corresponding to the min. output value of AO2 set in <b>P190</b> . |   |

**P187 Max. value of AO2 Selected Variable**

|             |                 |   |   |
|-------------|-----------------|---|---|
| <b>P187</b> | <b>Range</b>    | -32000 ÷ +32000<br>Depends on the value selected in <b>P185</b>   | -320.00 % ÷ +320.00 % of the full-scale value<br>See Table 34 |
|             | <b>Default</b>  | +1500   | +1500 rpm   |
|             | <b>Level</b>    | ADVANCED  |   |
|             | <b>Address</b>  | 787   |   |
|             | <b>Function</b> | Maximum value of the variable selected via <b>P185</b> , corresponding to the max. output value of AO2 set in <b>P191</b> . |   |

**P188 AO2 Analog Output Offset**

|             |                 |   |                |
|-------------|-----------------|---|----------------|
| <b>P188</b> | <b>Range</b>    | -9999 ÷ +9999<br>Depends on the value selected in <b>P184</b> | -9.999 ÷ 9.999 |
|             | <b>Default</b>  | 0   | 0.000 V        |
|             | <b>Level</b>    | ADVANCED  |                |
|             | <b>Address</b>  | 788   |                |
|             | <b>Function</b> | Offset value applied to AO2 analog output.                    |                |

**P189 Filter for AO2 Analog Output**

|             |                 |   |                     |
|-------------|-----------------|---|---------------------|
| <b>P189</b> | <b>Range</b>    | 0 ÷ 65000   | 0.000 ÷ 65.000 sec. |
|             | <b>Default</b>  | 0   | 0.000 sec.          |
|             | <b>Level</b>    | ADVANCED  |                     |
|             | <b>Address</b>  | 789   |                     |
|             | <b>Function</b> | Value of the filter time constant applied to AO2 analog output. |                     |

**P190 Min. AO2 Output Value with Reference to P186**

|             |                 |   |                                     |
|-------------|-----------------|---|-------------------------------------|
| <b>P190</b> | <b>Range</b>    | -100 ÷ +100<br>-200 ÷ +200<br>Depends on the value selected in <b>P184</b>                              | -10.0 ÷ +10.0 V<br>-20.0 ÷ +20.0 mA |
|             | <b>Default</b>  | -100  | -10.0 V                             |
|             | <b>Level</b>    | ADVANCED  |                                     |
|             | <b>Address</b>  | 790   |                                     |
|             | <b>Function</b> | Minimum output value obtained when the minimum value of the variable set in <b>P186</b> is implemented. |                                     |

**P191 Max. AO2 Output Value with Reference to P187**

|             |                 |   |                                     |
|-------------|-----------------|---|-------------------------------------|
| <b>P191</b> | <b>Range</b>    | -100 ÷ +100<br>-200 ÷ +200<br>Depends on the value selected in <b>P184</b>                              | -10.0 ÷ +10.0 V<br>-20.0 ÷ +20.0 mA |
|             | <b>Default</b>  | +100  | +10,0 V                             |
|             | <b>Level</b>    | ADVANCED  |                                     |
|             | <b>Address</b>  | 791   |                                     |
|             | <b>Function</b> | Maximum output value obtained when the maximum value of the variable set in <b>P187</b> is implemented. |                                     |

**P192 AO3 Analog Output**

|             |                 |  |   |
|-------------|-----------------|--|---|
| <b>P192</b> | <b>Range</b>    | 0 ÷ 7  | 0: Disabled,<br>1: ± 10V,<br>2: 0 ÷ 10V,<br>3: 0 ÷ 20mA,<br>4: 4 ÷ 20mA,<br>5: ABS 0 ÷ 10V,<br>6: ABS 0 ÷ 20mA,<br>7: ABS 4 ÷ 20mA. |
|             | <b>Default</b>  | 2  | 2: 0 ÷ 10V  |
|             | <b>Level</b>    | ADVANCED   |   |
|             | <b>Address</b>  | 792  |   |
|             | <b>Function</b> | Selects the operating mode of AO3 analog output. |   |



**NOTE**

Analog outputs are set as voltage outputs by default. To set them as current outputs, see the DIP-switch configuration and follow the instructions displayed on the keypad, or refer to the Sinus Penta's Installation Guide.

**P193 Selected Variable for AO3 Analog Output**

|             |                 |  |                  |
|-------------|-----------------|--|------------------|
| <b>P193</b> | <b>Range</b>    | 0 ÷ 69   | See Table 34     |
|             | <b>Default</b>  | 5  | 5: Motor current |
|             | <b>Level</b>    | ADVANCED   |                  |
|             | <b>Address</b>  | 793  |                  |
|             | <b>Function</b> | Selects the variable to be allocated to AO3 analog output. |                  |

**P194 Min. Value of AO3 Selected Variable**

|             |                 |   |   |
|-------------|-----------------|---|---|
| <b>P194</b> | <b>Range</b>    | -320.00 % ÷ +320.00 % of the full-scale value<br>Depends on the value selected through <b>P193</b>                          | -320.00 % ÷ +320.00 % of the full-scale value<br>See Table 34 |
|             | <b>Default</b>  | 0   | 0 A   |
|             | <b>Level</b>    | ADVANCED  |   |
|             | <b>Address</b>  | 794   |   |
|             | <b>Function</b> | Minimum value of the variable selected via <b>P193</b> , corresponding to the min. output value of AO3 set in <b>P198</b> . |   |

**P195 Max. Value of AO3 Selected Variable**

|             |                 |   |  |
|-------------|-----------------|---|--|
| <b>P195</b> | <b>Range</b>    | -320.00 % ÷ +320.00 % of the full-scale value<br>Depends on the value selected through <b>P193</b>                          | -320.00 % ÷ +320.00 % of the full-scale value<br>See Table 34              |
|             | <b>Default</b>  | Inverter I <sub>max</sub>   | Max. drive current depending on the drive size – see Table 79 and Table 83 |
|             | <b>Level</b>    | ADVANCED  |  |
|             | <b>Address</b>  | 795   |  |
|             | <b>Function</b> | Maximum value of the variable selected via <b>P193</b> , corresponding to the max. output value of AO3 set in <b>P199</b> . |  |

**P196 AO3 Analog Output Offset**

|             |                 |  |                 |
|-------------|-----------------|--|-----------------|
| <b>P196</b> | <b>Range</b>    | -9999 ÷ +9999<br>Depends on the value selected through <b>P192</b> | -9.999 ÷ +9.999 |
|             | <b>Default</b>  | 0  | 0.000 V         |
|             | <b>Level</b>    | ADVANCED   |                 |
|             | <b>Address</b>  | 796  |                 |
|             | <b>Function</b> | Offset value applied to AO3 analog output.                         |                 |

**P197 Filter for AO3 Analog Output**

|             |                 |   |                     |
|-------------|-----------------|---|---------------------|
| <b>P197</b> | <b>Range</b>    | 0 ÷ 65000 sec.  | 0.000 ÷ 65.000 sec. |
|             | <b>Default</b>  | 0   | 0.000 sec.          |
|             | <b>Level</b>    | ADVANCED  |                     |
|             | <b>Address</b>  | 797   |                     |
|             | <b>Function</b> | Value of the filter time constant applied to AO3 analog output. |                     |

**P198 Min. AO3 Output Value with Reference to P194**

|             |                 |   |                                     |
|-------------|-----------------|---|-------------------------------------|
| <b>P198</b> | <b>Range</b>    | -100 ÷ +100<br>-200 ÷ +200<br>Function according to the selection of <b>P192</b>                        | -10.0 ÷ +10.0 V<br>-20.0 ÷ +20.0 mA |
|             | <b>Default</b>  | 0   | 00.0 V                              |
|             | <b>Level</b>    | ADVANCED  |                                     |
|             | <b>Address</b>  | 798   |                                     |
|             | <b>Function</b> | Minimum output value obtained when the minimum value of the variable set in <b>P194</b> is implemented. |                                     |

**P199 Max. AO3 Output Value with Reference to P195**

|             |                 |   |                                     |
|-------------|-----------------|---|-------------------------------------|
| <b>P199</b> | <b>Range</b>    | -100 ÷ +100<br>-200 ÷ +200<br>Function according to selection of <b>P192</b>                            | -10.0 ÷ +10.0 V<br>-20.0 ÷ +20.0 mA |
|             | <b>Default</b>  | +100  | +10.0 V                             |
|             | <b>Level</b>    | ADVANCED  |                                     |
|             | <b>Address</b>  | 799   |                                     |
|             | <b>Function</b> | Maximum output value obtained when the maximum value of the variable set in <b>P195</b> is implemented. |                                     |

**P200 FOUT Output in [MDO1] Frequency**

|             |                 |  |   |
|-------------|-----------------|--|---|
| <b>P200</b> | <b>Range</b>    | 0 ÷ 2  | 0: Disabled,<br>1: Pulse,<br>2: ABS Pulse |
|             | <b>Default</b>  | 0  | 0: Disabled                               |
|             | <b>Level</b>    | ADVANCED   |   |
|             | <b>Address</b>  | 800  |   |
|             | <b>Function</b> | Selects the operating mode of FOUT frequency output. |   |

**NOTE**

When **P200** is not set to DISABLE, MDO1 digital output is used as a frequency output and any settings for MDO1 in the DIGITAL OUTPUTS MENU are ignored.

**P201 Selected Variable for FOUT Frequency Output**

|             |                 |  |              |
|-------------|-----------------|--|--------------|
| <b>P201</b> | <b>Range</b>    | 0 ÷ 69   | See Table 34 |
|             | <b>Default</b>  | 1  | Motor speed  |
|             | <b>Level</b>    | ADVANCED   |              |
|             | <b>Address</b>  | 801  |              |
|             | <b>Function</b> | Selects the variable to be allocated to FOUT frequency output. |              |

**P202 Min. FOUT Value of Selected Variable**

|             |                 |  |   |
|-------------|-----------------|--|---|
| <b>P202</b> | <b>Range</b>    | -32000 ÷ +32000<br>Depends on the value selected through <b>P201</b> | -320.00 % ÷ +320.00 % of the full-scale value<br>See Table 34 |
|             | <b>Default</b>  | 0  | 0   |
|             | <b>Level</b>    | ADVANCED   |   |
|             | <b>Address</b>  | 802  |   |
|             | <b>Function</b> | Minimum value of the selected variable.                              |   |

**P203 Max. FOUT Value of Selected Variable**

|             |                 |  |   |
|-------------|-----------------|--|---|
| <b>P203</b> | <b>Range</b>    | -32000 ÷ +32000<br>Depends on the value selected through <b>P201</b> | -320.00 % ÷ +320.00 % of the full-scale value<br>See Table 34 |
|             | <b>Default</b>  | 0  | 0   |
|             | <b>Level</b>    | ADVANCED   |   |
|             | <b>Address</b>  | 803  |   |
|             | <b>Function</b> | Maximum value of the selected variable.                              |   |

**P204 Min. FOUT Output Value with Reference to P202**

|             |                 |   |                  |
|-------------|-----------------|---|------------------|
| <b>P204</b> | <b>Range</b>    | 1000÷10000  | 10.00÷100.00 kHz |
|             | <b>Default</b>  | 1000  | 10.00 kHz        |
|             | <b>Level</b>    | ADVANCED  |                  |
|             | <b>Address</b>  | 804   |                  |
|             | <b>Function</b> | Minimum output value obtained when the minimum value of the variable set in <b>P202</b> is implemented. |                  |

**P205 Min. FOUT Output Value with Reference to P203**

|             |                 |   |                  |
|-------------|-----------------|---|------------------|
| <b>P205</b> | <b>Range</b>    | 1000÷10000  | 10.00÷100.00 kHz |
|             | <b>Default</b>  | 10000   | 100.00 kHz       |
|             | <b>Level</b>    | ADVANCED  |                  |
|             | <b>Address</b>  | 805   |                  |
|             | <b>Function</b> | Maximum output value obtained when the maximum value of the variable set in <b>P203</b> is implemented. |                  |

**P206 Filter for FOUT Frequency Output**

|             |                 |   |                    |
|-------------|-----------------|---|--------------------|
| <b>P206</b> | <b>Range</b>    | 0 ÷ 65000   | 0.000 ÷ 65.000 sec |
|             | <b>Default</b>  | 0   | 0.000 sec.         |
|             | <b>Level</b>    | ADVANCED  |                    |
|             | <b>Address</b>  | 806   |                    |
|             | <b>Function</b> | Value of the filter time constant applied to FOUT frequency output. |                    |

|  |                        |
|--|------------------------|
| <p><b><u>P207 AO1: Gain</u></b><br/> <b><u>P208 AO2: Gain</u></b><br/> <b><u>P209 AO3: Gain</u></b><br/> <b><u>P210 AO1: Variable MODBUS Address</u></b><br/> <b><u>P211 AO2: Variable MODBUS Address</u></b><br/> <b><u>P212 AO3: Variable MODBUS Address</u></b></p> | <p><b>RESERVED</b></p> |
|--|------------------------|

**P213 Amplitude of Sinusoidal Analog Output Signal**

|             |                 |  |            |
|-------------|-----------------|--|------------|
| <b>P213</b> | <b>Range</b>    | 0 ÷ 1000   | 0 ÷ 100.0% |
|             | <b>Default</b>  | 1000   | 100.0%     |
|             | <b>Level</b>    | ENGINEERING  |            |
|             | <b>Address</b>  | 813  |            |
|             | <b>Function</b> | Amplitude of the sinusoidal analog output signal when Sine or Cosine variables are selected. |            |

**P214 Frequency of Sinusoidal Analog Output Signal**

|             |                 |  |              |
|-------------|-----------------|--|--------------|
| <b>P214</b> | <b>Range</b>    | 0 ÷ 20000  | 0 ÷ 200.00Hz |
|             | <b>Default</b>  | 100  | 1.00Hz       |
|             | <b>Level</b>    | ENGINEERING  |              |
|             | <b>Address</b>  | 814  |              |
|             | <b>Function</b> | Frequency of the sinusoidal analog output signal when Sine or Cosine variables are selected. |              |

**P215 Frequency of Saw Wave Analog Output Signal**

|             |                 |   |              |
|-------------|-----------------|---|--------------|
| <b>P215</b> | <b>Range</b>    | 0 ÷ 20000   | 0 ÷ 200.00Hz |
|             | <b>Default</b>  | 100   | 1.00Hz       |
|             | <b>Level</b>    | ENGINEERING   |              |
|             | <b>Address</b>  | 815   |              |
|             | <b>Function</b> | Frequency of saw wave analog output signal when Sine or Cosine variables are selected. This can be used as the carrier frequency when setting MDO1 or MDO2 in PWM mode (see the example given in the DIGITAL OUTPUTS MENU). |              |

## 22. TIMERS MENU

### 22.1. Overview

---

The Timers menu allows setting enable and disable delay times for digital inputs/outputs.



**NOTE**

For the **ENABLE-A** and **ENABLE-B** digital inputs, no disable delay is allowed, because their logic status is utilized directly by the hardware activating IGBT switching; when no **ENABLE-A**, **ENABLE-B** command is sent, the output power stage is instantly deactivated.



**NOTE**

The **ENABLE-A** and **ENABLE-B** inputs are allocated to the STO function. If this safety functionality is to be adopted, the control mode and the control circuit of these signals must be accomplished as per the Safe Torque Off Function - Application Manual. That manual also includes a detailed validation procedure of the control configuration of the STO function to be executed upon first start-up and also periodically at yearly intervals.



**NOTE**

The reset function for the alarms on the leading edges of MDI3 is not delayed.



**NOTE**

Any auxiliary alarm set to the digital inputs is not delayed.



**NOTE**

Five timers are available; the user can set an enabling/disable delay for each of them. The same timer may also be assigned to multiple digital inputs/outputs.



**NOTE**

The **ENABLE-SW** function cannot be delayed.

#### Example 1:

The drive enable (**MDI1 START**) depends on a signal coming from a different source. An activation delay of 2 seconds and a deactivation delay of 5 seconds are needed. To do so, set two delay times for activation and deactivation for the same timer and assign it to **MDI1 (START)** digital input. In the example below, timer 1 is used.

|             |         |                                       |
|-------------|---------|---------------------------------------|
| <b>P216</b> | 2.0 sec | Activation delay T1                   |
| <b>P217</b> | 5.0 sec | Deactivation delay T1                 |
| <b>P226</b> | 0x0001  | Timer assigned to <b>MDI1 (START)</b> |

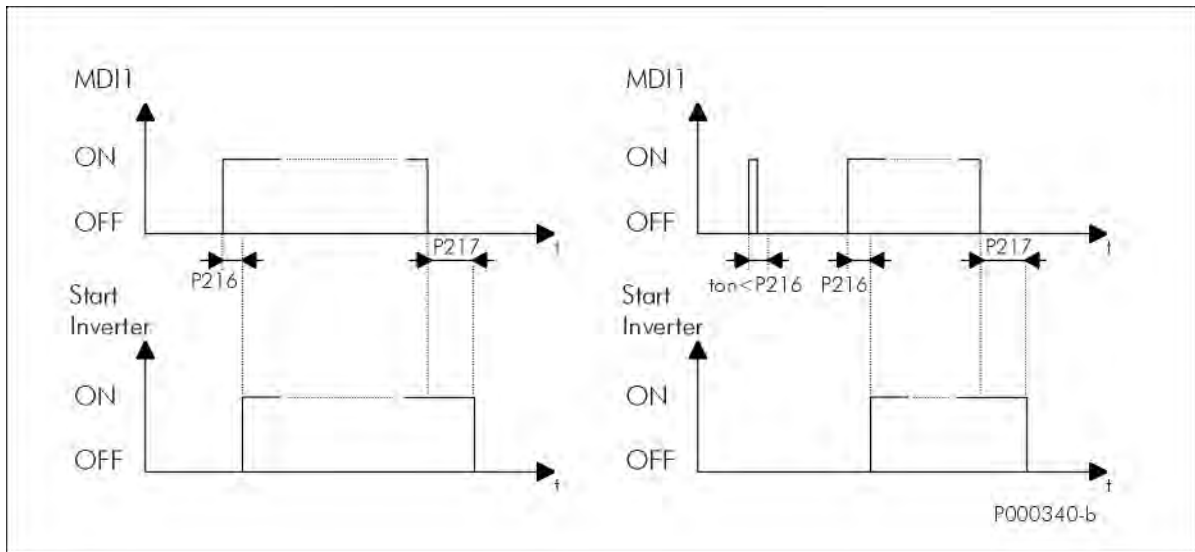

Figure 22: Using Timers (example)

The figure shows two possible operating modes:

- on the left: application of the delay times set for the drive enabling/disabling;
- on the right: the start signal persists for a shorter time than the delay set for enabling; in this case, the Start function is not enabled. The Start function will be enabled only when MDI1 digital input is ON for a time longer than the time set in P216.

## 22.2. List of Parameters P216 to P229

Table 41: List of parameters P216 to P229

| Parameter | FUNCTION                                 | User Level  | Default Values       | MODBUS Address |
|-----------|--|-------------|----------------------|----------------|
| P216      | T1 Enable delay                          | ENGINEERING | 0.0                  | 816            |
| P217      | T1 Disable delay                         | ENGINEERING | 0.0                  | 817            |
| P218      | T2 Enable delay                          | ENGINEERING | 0.0                  | 818            |
| P219      | T2 Disable delay                         | ENGINEERING | 0.0                  | 819            |
| P220      | T3 Enable delay                          | ENGINEERING | 0.0                  | 820            |
| P221      | T3 Disable delay                         | ENGINEERING | 0.0                  | 821            |
| P222      | T4 Enable delay                          | ENGINEERING | 0.0                  | 822            |
| P223      | T4 Disable delay                         | ENGINEERING | 0.0                  | 823            |
| P224      | T5 Enable delay                          | ENGINEERING | 0.0                  | 824            |
| P225      | T5 Disable delay                         | ENGINEERING | 0.0                  | 825            |
| P226      | Timer assigned to inputs MDI1÷4          | ENGINEERING | 0: No timer assigned | 826            |
| P227      | Timer assigned to inputs MDI5÷8          | ENGINEERING | 0: No timer assigned | 827            |
| P228      | Timer assigned to outputs MDO1÷4         | ENGINEERING | 0: No timer assigned | 828            |
| P229      | Timer assigned to virtual outputs MPL1÷4 | ENGINEERING | 0: No timer assigned | 829            |

### P216 T1 Enable delay

| P216 | Range    | 0 ÷ 60000   | 0.0 ÷ 6000.0 sec |
|------|----------|---|------------------|
|      | Default  | 0   | 0.0              |
|      | Level    | ENGINEERING   |                  |
|      | Address  | 816   |                  |
|      | Function | This parameter sets T1 enable time.<br>Using <b>P226</b> or <b>P227</b> , if <b>timer T1</b> is assigned to a digital input having a particular function, P216 represents the delay occurring between the input closure and the function activation.<br>Use <b>P228</b> to assign timer 1 to a digital output; in that case, the digital output energizing will be delayed according to the time set in <b>P216</b> . |                  |

### P217 T1 Disable delay

| P217 | Range    | 0 ÷ 60000   | 0.0 ÷ 6000.0 sec |
|------|----------|---|------------------|
|      | Default  | 0   | 0.0              |
|      | Level    | ENGINEERING   |                  |
|      | Address  | 817   |                  |
|      | Function | This parameter sets T1 disabling time.<br>Using <b>P226</b> or <b>P227</b> , if <b>timer T1</b> is assigned to a digital input having a particular function, this parameter represents the delay occurring between the input opening and the function deactivation.<br>Use <b>P228</b> to assign timer 1 to a digital output; in that case, the digital output de-energizing will be delayed according to the time set in <b>P217</b> . |                  |

**P218 T2 Enable delay**

|             |                 |   |                  |
|-------------|-----------------|---|------------------|
| <b>P218</b> | <b>Range</b>    | 0 ÷ 60000   | 0.0 ÷ 6000.0 sec |
|             | <b>Default</b>  | 0   | 0.0              |
|             | <b>Level</b>    | ENGINEERING   |                  |
|             | <b>Address</b>  | 818   |                  |
|             | <b>Function</b> | This parameter sets T2 enable time.<br>(Operation as per <b>P216</b> .) |                  |

**P219 T2 Disable delay**

|             |                 |  |                  |
|-------------|-----------------|--|------------------|
| <b>P219</b> | <b>Range</b>    | 0 ÷ 60000  | 0.0 ÷ 6000.0 sec |
|             | <b>Default</b>  | 0  | 0.0              |
|             | <b>Level</b>    | ENGINEERING  |                  |
|             | <b>Address</b>  | 819  |                  |
|             | <b>Function</b> | This parameter sets T2 disable time.<br>(Operation as per <b>P217</b> .) |                  |

**P220 T3 Enable delay**

|             |                 |   |                  |
|-------------|-----------------|---|------------------|
| <b>P220</b> | <b>Range</b>    | 0 ÷ 60000   | 0.0 ÷ 6000.0 sec |
|             | <b>Default</b>  | 0   | 0.0              |
|             | <b>Level</b>    | ENGINEERING   |                  |
|             | <b>Address</b>  | 820   |                  |
|             | <b>Function</b> | This parameter sets T3 enable time.<br>(Operation as per <b>P216</b> .) |                  |

**P221 T3 Disable delay**

|             |                 |  |                  |
|-------------|-----------------|--|------------------|
| <b>P221</b> | <b>Range</b>    | 0 ÷ 60000  | 0.0 ÷ 6000.0 sec |
|             | <b>Default</b>  | 0  | 0.0              |
|             | <b>Level</b>    | ENGINEERING  |                  |
|             | <b>Address</b>  | 821  |                  |
|             | <b>Function</b> | This parameter sets T3 disable time.<br>(Operation as per <b>P217</b> .) |                  |

**P222 T4 Enable delay**

|             |                 |   |                  |
|-------------|-----------------|---|------------------|
| <b>P222</b> | <b>Range</b>    | 0 ÷ 60000   | 0.0 ÷ 6000.0 sec |
|             | <b>Default</b>  | 0   | 0.0              |
|             | <b>Level</b>    | ENGINEERING   |                  |
|             | <b>Address</b>  | 822   |                  |
|             | <b>Function</b> | This parameter sets T4 enable time.<br>(Operation as per <b>P216</b> .) |                  |

**P223 T4 Disable delay**

|             |                 |  |                  |
|-------------|-----------------|--|------------------|
| <b>P223</b> | <b>Range</b>    | 0 ÷ 60000  | 0.0 ÷ 6000.0 sec |
|             | <b>Default</b>  | 0  | 0.0              |
|             | <b>Level</b>    | ENGINEERING  |                  |
|             | <b>Address</b>  | 823  |                  |
|             | <b>Function</b> | This parameter sets T4 disable time.<br>(Operation as per <b>P217</b> .) |                  |

**P224 T5 Enable delay**

|             |                 |   |                  |
|-------------|-----------------|---|------------------|
| <b>P224</b> | <b>Range</b>    | 0 ÷ 60000   | 0.0 ÷ 6000.0 sec |
|             | <b>Default</b>  | 0   | 0.0              |
|             | <b>Level</b>    | ENGINEERING   |                  |
|             | <b>Address</b>  | 824   |                  |
|             | <b>Function</b> | This parameter sets T5 enable time.<br>(Operation as per <b>P216</b> .) |                  |

**P225 T5 Disable delay**

|             |                 |  |                  |
|-------------|-----------------|--|------------------|
| <b>P225</b> | <b>Range</b>    | 0 ÷ 60000  | 0.0 ÷ 6000.0 sec |
|             | <b>Default</b>  | 0  | 0.0              |
|             | <b>Level</b>    | ENGINEERING  |                  |
|             | <b>Address</b>  | 825  |                  |
|             | <b>Function</b> | This parameter sets T5 disable time.<br>(Operation as per <b>P217</b> .) |                  |

**P226 Timers Assigned to Inputs MDI1÷4**

|             |                 |  |  |
|-------------|-----------------|--|--|
| <b>P226</b> | <b>Range</b>    | [ 0; 0; 0; 0 ] ÷ [ 5; 5; 5; 5 ]  | 0: No timer assigned<br>1 ÷ 5: T1 ÷ T5 |
|             | <b>Default</b>  | [ 0; 0; 0; 0 ]   | 0: No timer assigned                   |
|             | <b>Level</b>    | ENGINEERING  |  |
|             | <b>Address</b>  | 826  |  |
|             | <b>Function</b> | The first group of four digital inputs may be assigned to any of the five timers and the same timer may be assigned to multiple inputs.<br>Select “zero” to avoid delaying the digital inputs.<br>Setting via serial link: see coding table below. |  |

**Table 42: Coding of P226: Timers assigned to digital inputs MDI 1÷4**

| bits [15..12] | bits [11..9] | bits [8..6] | bits [5..3] | bits [2..0] |
|---------------|--------------|-------------|-------------|-------------|
| not used      | MDI4         | MDI3        | MDI2        | MDI1        |

**Coding example for P226:**

MDI1=Timer T2  
 MDI2=No timer assigned  
 MDI3=Timer T2  
 MDI4=Timer T5  
 ⇒ value in **P226** 101 010 000 010 bin = 2690 dec

**P227 Timers Assigned to Inputs MDI5÷8**

|             |                 |   |  |
|-------------|-----------------|---|--|
| <b>P227</b> | <b>Range</b>    | [ 0; 0; 0; 0 ] ÷ [ 5; 5; 5; 5 ]   | 0: No timer assigned<br>1 ÷ 5: T1 ÷ T5 |
|             | <b>Default</b>  | [ 0; 0; 0; 0 ]  | 0: No timer assigned                   |
|             | <b>Level</b>    | ENGINEERING   |  |
|             | <b>Address</b>  | 827   |  |
|             | <b>Function</b> | The second group of four digital inputs may be assigned to any of the five timers and the same timer may be assigned to multiple inputs.<br>Select “zero” to avoid delaying the digital inputs.<br>Setting via serial link: see coding in <b>P226</b> . |  |

**P228 Timers Assigned to Outputs MDO1÷4**

|             |                 |   |  |
|-------------|-----------------|---|--|
| <b>P228</b> | <b>Range</b>    | [ 0; 0; 0; 0 ] ÷ [ 5; 5; 5; 5 ]   | 0: No timer assigned<br>1 ÷ 5: T1 ÷ T5 |
|             | <b>Default</b>  | [ 0; 0; 0; 0 ]  | 0: No timer assigned                   |
|             | <b>Level</b>    | ENGINEERING   |  |
|             | <b>Address</b>  | 828   |  |
|             | <b>Function</b> | The digital outputs may be assigned to any of the five timers and the same timer may be assigned to multiple outputs.<br>Select "zero" to avoid delaying the digital outputs.<br>Setting via serial link: see coding in <b>P226</b> . |  |

**P229 Timers Assigned to Virtual Outputs MPL 1÷4**

|             |                 |   |  |
|-------------|-----------------|---|--|
| <b>P229</b> | <b>Range</b>    | [ 0; 0; 0; 0 ] ÷ [ 5; 5; 5; 5 ]   | 0: No timer assigned<br>1 ÷ 5: T1 ÷ T5 |
|             | <b>Default</b>  | [ 0; 0; 0; 0 ]  | 0: No timer assigned                   |
|             | <b>Level</b>    | ENGINEERING   |  |
|             | <b>Address</b>  | 829   |  |
|             | <b>Function</b> | The virtual digital outputs may be assigned to any of the five timers and the same timer may be assigned to multiple outputs.<br>Select "zero" to avoid delaying the virtual digital outputs.<br>Setting via serial link: see coding in P226. |  |

## 23. VTC DEAD TIME COMPENSATION MENU

### 23.1. Overview

The VTC Dead Time Compensation menu enables setting the operating modes and the parameters relating to the dead times of the VTC algorithm. The IFD and FOC algorithms follow the same compensation mode as the one that can be assigned to the VTC algorithm if **P230 = 1**.



**NOTE**

The VTC Dead Time Compensation parameters do not affect the Dead Time compensation modes when the IFD (**C010/C053/C096 = 0**) or FOC (**C010/C053/C096 = 2**) algorithms are activated. See MOTOR CONFIGURATION MENU.

### 23.2. List of Parameters P230 to P234

Table 43: List of parameters P230 to P234

| Parameter   | FUNCTION                      | Access Level | DEFAULT VALUES      | MODBUS Address |
|-------------|-------------------------------|--------------|---------------------|----------------|
| <b>P230</b> | Compensation Mode Selector    | ENGINEERING  | 2: Compensation 2   | 830            |
| <b>P231</b> | Positive Current Threshold    | ENGINEERING  | Based on drive size | 831            |
| <b>P232</b> | Negative Current Threshold    | ENGINEERING  | Based on drive size | 832            |
| <b>P233</b> | Positive Current Compensation | ENGINEERING  | Based on drive size | 833            |
| <b>P234</b> | Negative Current Compensation | ENGINEERING  | Based on drive size | 834            |

#### P230 Compensator Mode Selector

|             |                 |  |   |
|-------------|-----------------|--|---|
| <b>P230</b> | <b>Range</b>    | 0 ÷ 2  | 0: Disabled<br>1: Compensation 1<br>2: Compensation 2 |
|             | <b>Default</b>  | 2  | 2: Compensation 2                                     |
|             | <b>Level</b>    | ENGINEERING  |   |
|             | <b>Address</b>  | 830  |   |
|             | <b>Control</b>  | VTC  |   |
|             | <b>Function</b> | Selector of the type of dead time compensation for the VTC algorithm. It is recommended that value 2: Compensation 2 (default) be maintained unless specified otherwise by Elettronica Santerno. |   |

#### P231 Positive Current Threshold

|             |                 |  |                     |
|-------------|-----------------|--|---------------------|
| <b>P231</b> | <b>Range</b>    | 0 ÷ 10000  | 0.00 ÷ 100.00 %     |
|             | <b>Default</b>  | Based on drive size  | Based on drive size |
|             | <b>Level</b>    | ENGINEERING  |                     |
|             | <b>Address</b>  | 831  |                     |
|             | <b>Control</b>  | VTC  |                     |
|             | <b>Function</b> | Positive current threshold for the adoption of the dead time when <b>P230 = 2</b> : Compensation 2. It is recommended that value 2: Compensation 2 (default) be maintained unless specified otherwise by Elettronica Santerno. |                     |

**P232 Negative Current Threshold**

|             |                 |   |                     |
|-------------|-----------------|---|---------------------|
| <b>P232</b> | <b>Range</b>    | 0 ÷ 10000   | 0.00 ÷ 100.00 %     |
|             | <b>Default</b>  | Based on drive size   | Based on drive size |
|             | <b>Level</b>    | ENGINEERING   |                     |
|             | <b>Address</b>  | 832   |                     |
|             | <b>Control</b>  | VTC   |                     |
|             | <b>Function</b> | Negative current threshold for the adoption of the dead time when <b>P230 = 2: Compensation 2</b> .<br>It is recommended that value 2: Compensation 2 (default) be maintained unless specified otherwise by Elettronica Santerno. |                     |

**P233 Positive Current Compensation**

|             |                 |  |                      |
|-------------|-----------------|--|----------------------|
| <b>P233</b> | <b>Range</b>    | -10000 ÷ +10000                                      | -10.000 ÷ +10.000 µs |
|             | <b>Default</b>  | Based on drive size                                  | Based on drive size  |
|             | <b>Level</b>    | ENGINEERING  |                      |
|             | <b>Address</b>  | 833  |                      |
|             | <b>Control</b>  | VTC  |                      |
|             | <b>Function</b> | Dead-time compensation when the current is positive. |                      |

**P234 Negative Current Compensation**

|             |                 |  |                      |
|-------------|-----------------|--|----------------------|
| <b>P234</b> | <b>Range</b>    | -10000 ÷ +10000                                      | -10.000 ÷ +10.000 µs |
|             | <b>Default</b>  | Based on drive size                                  | Based on drive size  |
|             | <b>Level</b>    | ENGINEERING  |                      |
|             | <b>Address</b>  | 834  |                      |
|             | <b>Control</b>  | VTC  |                      |
|             | <b>Function</b> | Dead-time compensation when the current is negative. |                      |

## 24. PID PARAMETERS MENU

### 24.1. Overview

This menu defines the parameters for the digital PID regulator integrated in the drive.

The PID regulator may be used to control a physical variable which is external to the drive; the variable measure shall be available in the system and must be connected to the "feedback" input.

The PID regulator is used to keep the reference and the control variable constant (feedback); to do so, the PID regulator controls three internal variables, which are described below:

- ✓ Proportional term: this is the variable detecting the instant difference between the reference and the measured value of the physical variable to be controlled ("error");
- ✓ Integral term: this is the variable keeping track of the "history" of the detected errors (summation of all errors);
- ✓ Derivative term: this is the variable keeping track of the evolution of the error or the controlled variable (difference between two consecutive errors or between two consecutive values of the feedbacked variable);

The weighted summation of these terms represents the output signal of the PID regulator. The weight of these three terms may be defined by the user with the parameters below.

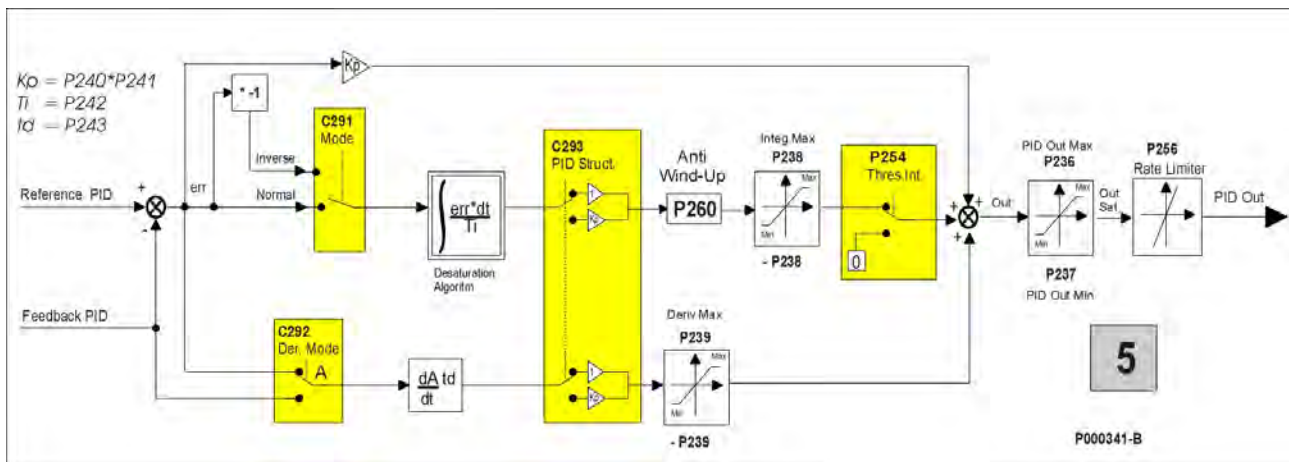

Figure 23: PID Block Diagram



NOTE

In **LOCAL mode**, the PID regulator is disabled if it is used to correct the reference or the voltage values (**C294 = 2: Add Reference** or **C294 = 3: Add Voltage**).



NOTE

In **LOCAL mode**, if the drive reference is the PID output **C294=Reference** and the Type parameter on the Keypad page in Local mode is **P266=Ref.Active+Spd**, the PID reference can be changed by activating the Local mode from the Keypad page. Press the **LOC/REM** key again when the drive is disabled (or the MDI LOC/REM key if it is programmed as a pushbutton: **C180a=Pushbutton**) to disable the PID and to set the speed reference directly from the Keypad page.

## 24.2. PID Regulator Tuning – Method of Ziegler and Nichols

Tuning a PID regulator consists in selecting and allocating values to PID parameters in order to adjust the operation of the system to the technical requirements of the process and to the equipment restrictions. One of the possible PID tuning procedures is the **Method of Ziegler and Nichols**.

This method implies the following steps:

1. Set the integral action and the derivative action to zero:  $T_i$  (P242) = 0,  $T_d$  (P243) = 0.
2. Assign very low values to  $K_p$  (P240), then apply a little step to the reference signal (setpoint) selected with C285/286/287.
3. Gradually increase the value of  $K_p$  until **permanent oscillation** is attained in the PID loop.
4. Tune the parameters for a **P**, **PI** or **PID** regulator based on the table below—where  $K_{pc}$  is the value of the proportional gain corresponding to the permanent oscillation (critical gain) and  $T_c$  is the period of the permanent oscillation:

|     | $K_p$ (P240)  | $T_i$ (P242) | $T_d$ (P243) |
|-----|---------------|--------------|--------------|
| P   | $0.5 K_{pc}$  |              |              |
| PI  | $0.45 K_{pc}$ | $T_c/1.2$    |              |
| PID | $0.6 K_{pc}$  | $T_c/2$      | $T_c/8$      |

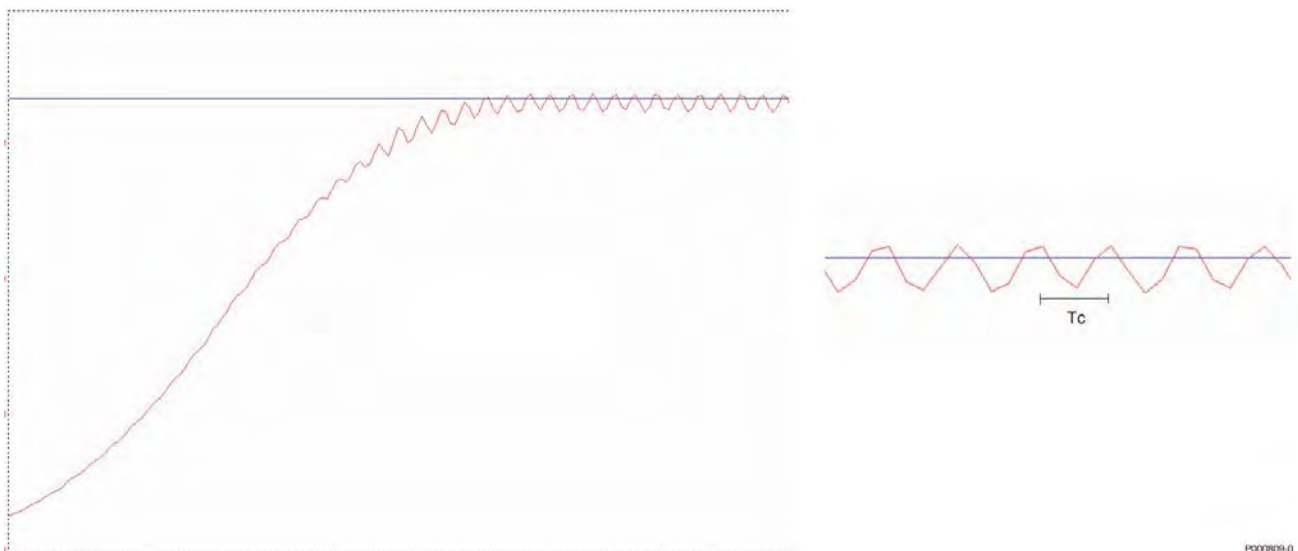
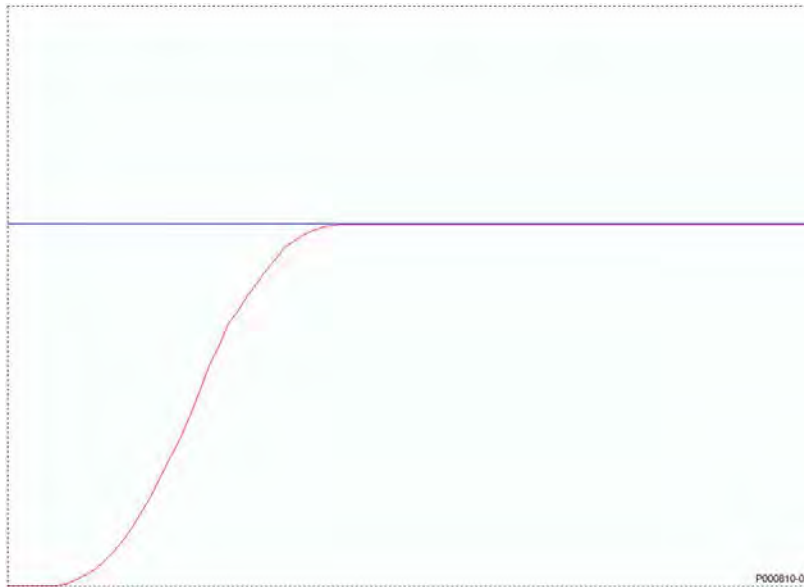

Figure 24: Permanent oscillation with  $K_{pc}$  critical gain



**Figure 25: Response to a system tuned with the method of Ziegler and Nichols**



**NOTE**

The method of Ziegler and Nichols is not always applicable, because some systems do not produce any oscillations, even in presence of large proportional gains. However, leading a system close to instability can be very dangerous.

## 24.3. Manual Tuning of the PI Regulator

The PI regulator can be manually tuned when the tuning method of Ziegler and Nichols is not applicable. The sections below cover the following:

- how the transient is affected from the proportional action when the integral action is kept constant in a PI regulator;
- how the transient is affected from the integral action when the proportional action is kept constant in a PI regulator;
- how the transient is affected from the derivative action in a PID regulator.

### 24.3.1. PROPORTIONAL ACTION (P)

| Symbol | Tuning function  | Main goal   |
|--------|--|---|
| $K_p$  | An input variance (error) produces an output variance proportional to the variance amplitude | Changes the tuning variable based on the variable being tuned |

| PI Regulator<br>$T_i=Constant$ | Response to the step | Response time |
|--------------------------------|----------------------|---------------|
| Small $K_p$                    | Overshoot            | Longer        |
| Optimum $K_p$                  | Optimum              | Optimum       |
| Large $K_p$                    | Undershoot           | Shorter       |

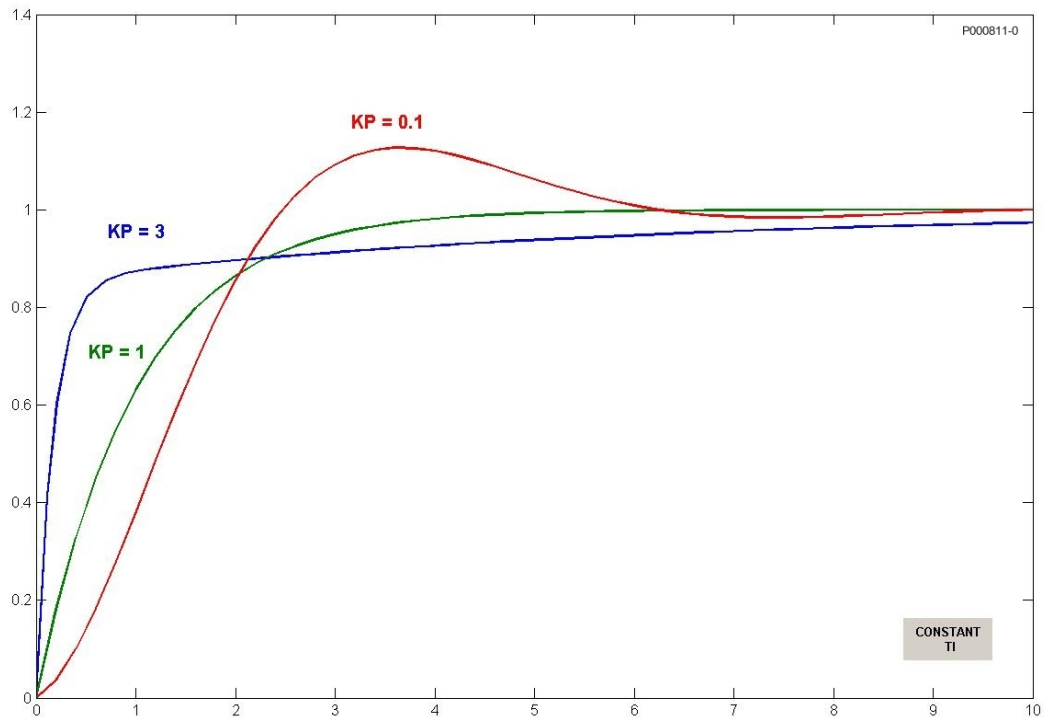

Figure 26: Response to the step based on the value of Kp when Ti is kept constant

When  $K_p$  is increased, the error is reduced at constant rate, but the transient can also be adversely affected. Adverse effects can be a longer transient with stronger oscillations due to the damping reduction, or even instability. This is shown in the figure below:

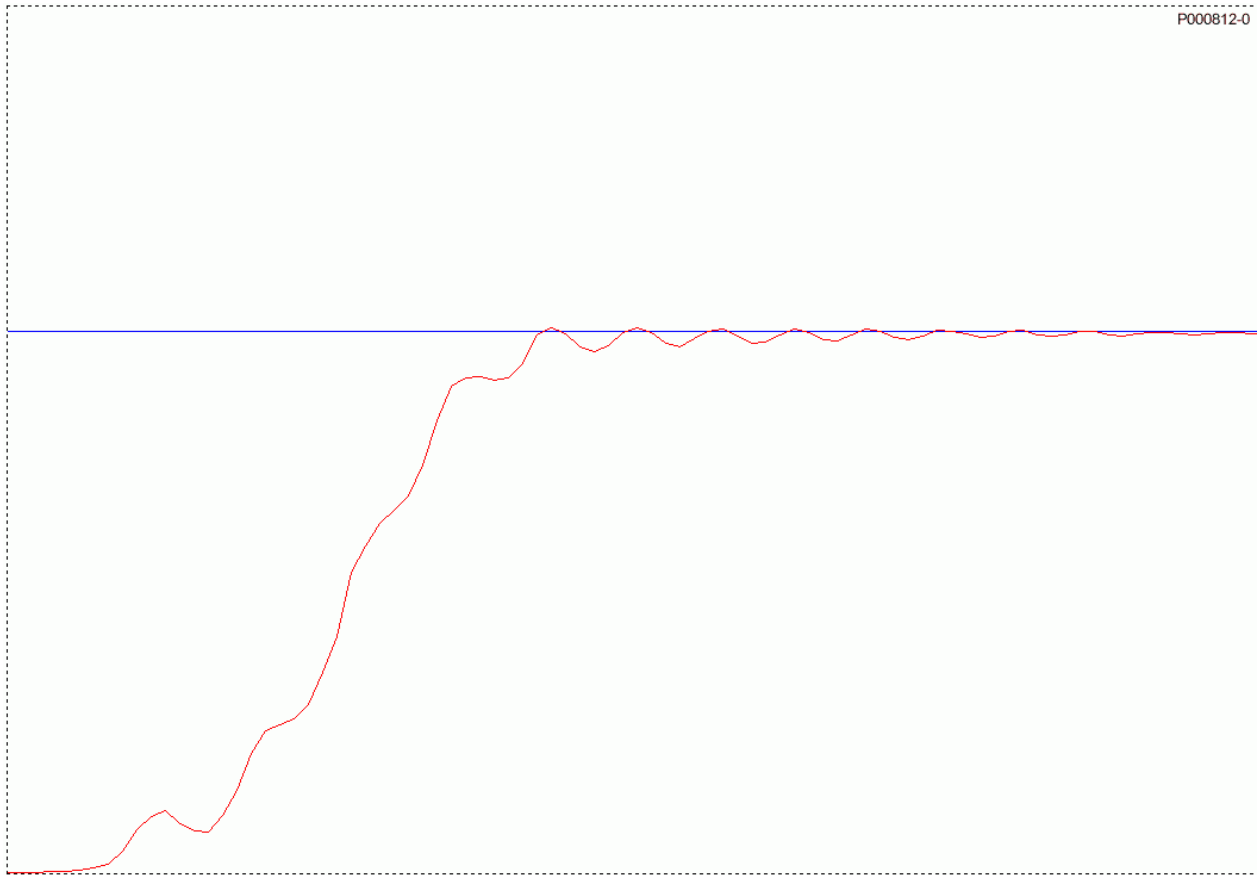

Figure 27: Response to the step when  $K_p$  is too large

### 24.3.2. INTEGRAL ACTION (I)

| Symbol | Tuning function  | Main goal   |
|--------|--|---|
| $T_i$  | As soon as an input variance occurs (Error), an output variance occurs. The variation rate is proportional to the error magnitude. | Sets the tuning point (eliminates the offset from the proportional action). |

| PI Regulator  | Response to the step | Response time |
|---------------|----------------------|---------------|
| Small $K_p$   | Overshoot            | Shorter       |
| Optimum $K_p$ | Optimum              | Optimum       |
| Large $K_p$   | Undershoot           | Longer        |

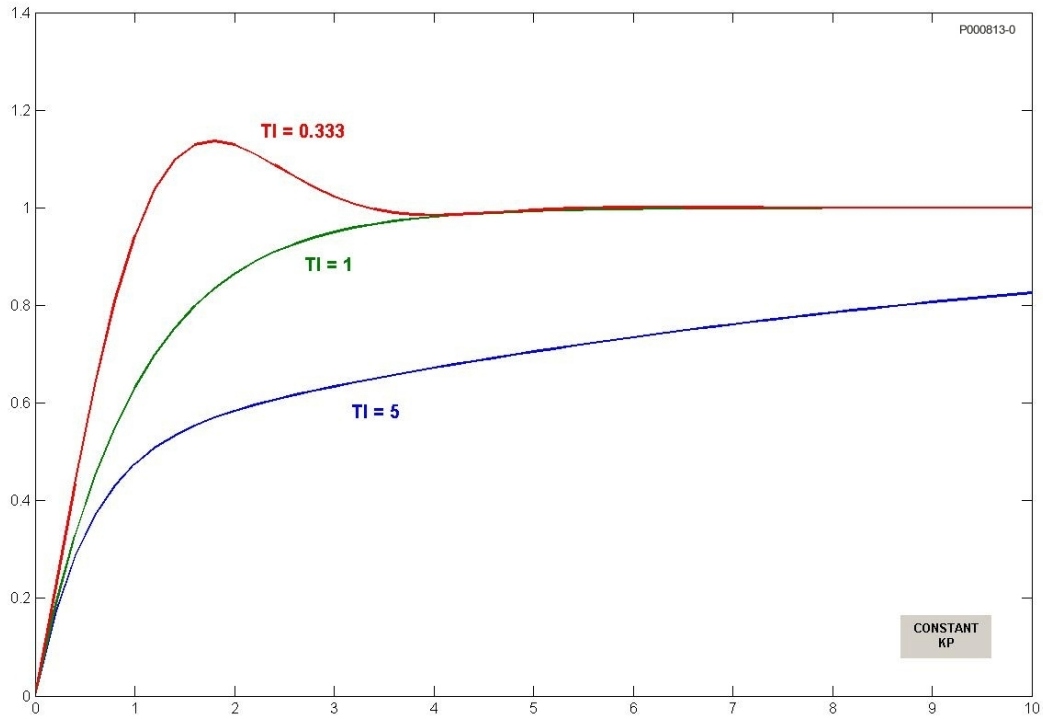

Figure 28: Response to the step based on the value of  $T_i$  when  $K_p$  is kept constant

The figure below represents the response of the PI regulator when the values for  $K_p$  and  $T_i$  are lower than the optimum value computed with the *method of Ziegler and Nichols*.

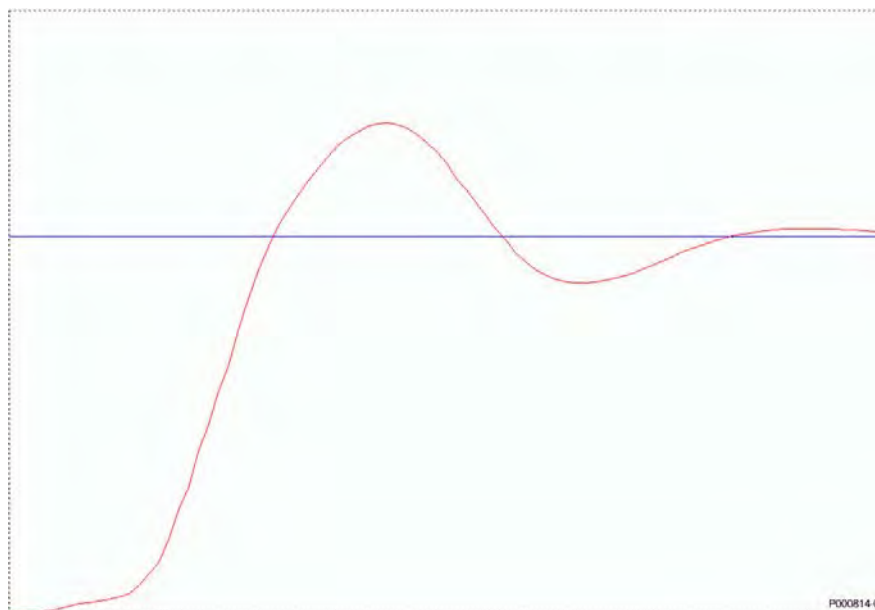

Figure 29: Response to the step when the values of  $K_p$  and  $T_i$  are too small

### 24.3.3. DERIVATIVE ACTION (D)

| Symbol | Tuning function  | Main goal  |
|--------|--|--|
| Td     | An input variance (error) generates an output variance proportional to the variance rate | Decreases the response time for the return to the tuning point |

The derivative action set with Td increases the stability of the system, thus increasing the transient response. The derivative action tends to get an earlier response, but it increases the system sensitivity to the disturbance overriding the error signal.

### 24.3.4. TUNING ACTIONS AT CONSTANT SPEED

When the system is operating at constant speed, the system response shall be the most accurate as possible (minimum error) and shall adjust any little reference variations.

When at constant speed, if the system does not promptly respond to little reference variations, a shorter integral time may solve this problem. Otherwise, when little and long-lasting oscillations affect the reference value, setting a longer integral time could be the right solution.

## 24.4. Anti-windup

---

The major benefit of the integral action is to ensure null errors at steady speed. However, just like the derivative action, the integral action shall be applied with caution to avoid worse performance.

A case in point is the output saturation occurring at the same time as an excessive integral action. When the output saturates, the control action is limited, so the error is still remarkable. If the error persists, the actuator will saturate, because the longer the time the error persists, the stronger the integral action is; this phenomenon is called "windup". In case of output saturation, the integral term can reach very high values; as a result, the error shall have opposite sign for a long period before exiting from saturation.

The PID regulator of the Penta drive is provided with an Anti-windup function which compensates the effect described above. This Anti-windup action is described below (P=proportional term; I=integral term; D=derivative term).

The output is always calculated as follows:

$$\text{OUT} \leftarrow \text{P} + \text{I} + \text{D}$$

When output saturation occurs:

$$\text{OUT} \leftarrow \text{OUT}_{\text{sat}}$$

The integral term is forced based on the following:

$$\text{I} \leftarrow \text{OUT}_{\text{sat}} - \text{P} - \text{D}$$

(which is the Anti-windup function).

This prevents the integral term from reaching very high values; the integral term is then kept constantly in line with the saturated output value  $\text{OUT}_{\text{sat}}$  that is present at each moment; any variations of the error (i.e. the P) that allows exiting from saturation have immediate effect to the output, without having to wait for a long time before discharging the integral term itself.

The effect of the Anti-windup can be adjusted with parameter **P260**; if **P260**<1, the effect is reduced and the system is less sensitive to error variations; if **P260**=0, the effect is cancelled.

The value of **P260**=1 is correct for the applications requiring to quickly exit from saturation.

On the other hand, reducing **P260** can be useful when output variations are to be avoided for negligible error variations.

## 24.5. List of Parameters P236 to P260

Table 44: List of parameters P236 to P260

| Parameter    | FUNCTION   | User Level  | Default Values | MODBUS Address |
|--------------|--|-------------|----------------|----------------|
| <b>P236</b>  | Max. value of PID output                             | ENGINEERING | +100.00%       | 836            |
| <b>P237</b>  | Min. value of PID output                             | ENGINEERING | -100.00%       | 837            |
| <b>P237a</b> | Wake-up Mode   | ENGINEERING | 0: [Disabled]  | 858            |
| <b>P237b</b> | Wake-up Level  | ENGINEERING | 0.00%          | 859            |
| <b>P238</b>  | Max. value of PID integral term                      | ENGINEERING | +100.00%       | 838            |
| <b>P239</b>  | Max. value of PID derivative term                    | ENGINEERING | +100.00%       | 839            |
| <b>P240</b>  | PID proportional constant                            | ENGINEERING | 1.000          | 840            |
| <b>P241</b>  | Multiplicative factor of <b>P240</b>                 | ENGINEERING | 0:1.0          | 841            |
| <b>P242</b>  | PID Integral time (multiples of <b>P244</b> )        | ENGINEERING | 500*Tc (ms)    | 842            |
| <b>P243</b>  | PID Derivative time (multiples of <b>P244</b> )      | ENGINEERING | 0*Tc (ms)      | 843            |
| <b>P244</b>  | Cycle time of PID regulator: Tc                      | ENGINEERING | 5 ms           | 844            |
| <b>P245</b>  | Min. value of PID reference                          | ENGINEERING | 0.00%          | 845            |
| <b>P246</b>  | Max. value of PID reference                          | ENGINEERING | +100.00%       | 846            |
| <b>P247</b>  | Min. value of PID feedback                           | ENGINEERING | 0.00%          | 847            |
| <b>P248</b>  | Max. value of PID feedback                           | ENGINEERING | +100.00%       | 848            |
| <b>P249</b>  | PID reference ramp up time                           | ENGINEERING | 0 s            | 849            |
| <b>P250</b>  | PID reference ramp down time                         | ENGINEERING | 0 s            | 850            |
| <b>P251</b>  | Unit of measure of PID ramp                          | ENGINEERING | 1: [0.1s]      | 851            |
| <b>P252</b>  | PID ramp start rounding off                          | ENGINEERING | 50%            | 852            |
| <b>P253</b>  | PID ramp end rounding off                            | ENGINEERING | 50%            | 853            |
| <b>P254</b>  | Integral term activation threshold                   | ENGINEERING | 0.00%          | 854            |
| <b>P255</b>  | <b>START</b> Disable delay with PID Out= <b>P237</b> | ENGINEERING | 0: [Disabled]  | 855            |
| <b>P256</b>  | PID output gradient limit                            | ENGINEERING | 1 ms           | 856            |
| <b>P257</b>  | Gain for PID measure scaling                         | ENGINEERING | 1.000          | 857            |
| <b>P260</b>  | Gain for Anti-windup                                 | ENGINEERING | 1.00           | 860            |

**P236 Max. Value of PID Output**

|             |                 |   |                     |
|-------------|-----------------|---|---------------------|
| <b>P236</b> | <b>Range</b>    | -10000 ÷ +10000   | -100.00 ÷ +100.00 % |
|             | <b>Default</b>  | +10000  | +100.00 %           |
|             | <b>Level</b>    | ENGINEERING   |                     |
|             | <b>Address</b>  | 836   |                     |
|             | <b>Function</b> | <p>This is the max. allowable value of PID regulator output. This value is expressed as a percentage; its allocation depends on parameter <b>C294</b>, defining PID action.</p> <p>Example: if <b>C294 = External Out</b>, the PID regulator delivers a reference obtained based on the controlled variable and its setpoint. In this case, the PID output can be brought outside through an analog output. The matching between <b>P236</b> and the output value (see the ANALOG AND FREQUENCY OUTPUTS MENU) is user-defined.</p> <p>If <b>C294 = Reference</b>, the PID regulator output is the motor speed/torque reference (the system will ignore any other reference source), parameter <b>P236</b> is a percentage referring to the max. value, considered as an absolute value, between the max. and the min. speed/torque reference of the active motor.</p> <p>If <b>C294 = Add Reference</b>, the percentage in <b>P236</b> relates to the instant value of the speed/torque reference to be adjusted.</p> <p>If a Frequency control is used, the PID regulator can be used to adjust the drive output voltage; in this case, <b>P236</b> relates to the instant voltage value (E.g. If a drive delivers 50V and an adjustment of 10% is implemented, the drive will deliver 55V).</p> |                     |

**P237 Min. Value of PID Output**

|             |                 |  |                     |
|-------------|-----------------|--|---------------------|
| <b>P237</b> | <b>Range</b>    | -10000 ÷ +10000  | -100.00 ÷ +100.00 % |
|             | <b>Default</b>  | -10000   | -100.00 %           |
|             | <b>Level</b>    | ENGINEERING  |                     |
|             | <b>Address</b>  | 837  |                     |
|             | <b>Function</b> | <p>This is the min. allowable value of PID regulator output. For the value percent of <b>P237</b>, see the description of parameter <b>P236</b>.</p> |                     |

**P237a Wake-up Mode**

|              |                 |   |   |
|--------------|-----------------|---|---|
| <b>P237a</b> | <b>Range</b>    | 0 ÷ 4   | 0: Disabled<br>1: Feedback < <b>P237b</b><br>2: Feedback > <b>P237b</b><br>3: Error < <b>P237b</b><br>4: Error > <b>P237b</b> |
|              | <b>Default</b>  | 0   | 0: Disabled   |
|              | <b>Level</b>    | ENGINEERING   |   |
|              | <b>Address</b>  | 858   |   |
|              | <b>Function</b> | <p>If this parameter is disabled, the PID control re-activates only when the PID output exceeds the value set in parameter <b>P237</b>.</p> <p>If this parameter is enabled, the PID control re-activates when the PID output exceeds the threshold set in parameter <b>P237</b> and:</p> <p><b>P237a=1</b>: the Feedback value drops below the level set with <b>P237b</b>;<br/> <b>P237a=2</b>: the Feedback value exceeds the level set with <b>P237b</b>;<br/> <b>P237a=3</b>: the Error value drops below the level set with <b>P237b</b>;<br/> <b>P237a=4</b>: the Error value exceeds the level set with <b>P237b</b>.</p> |   |

**P237b Wake-up Level**

|              |                 |   |                     |
|--------------|-----------------|---|---------------------|
| <b>P237b</b> | <b>Range</b>    | -10000 ÷ +10000   | -100.00 ÷ +100.00 % |
|              | <b>Default</b>  | 0   | 0.00 %              |
|              | <b>Level</b>    | ENGINEERING   |                     |
|              | <b>Address</b>  | 859   |                     |
|              | <b>Function</b> | Level of the Feedback or Error signal allowing re-activating the PID control (see <b>P237a</b> ). |                     |

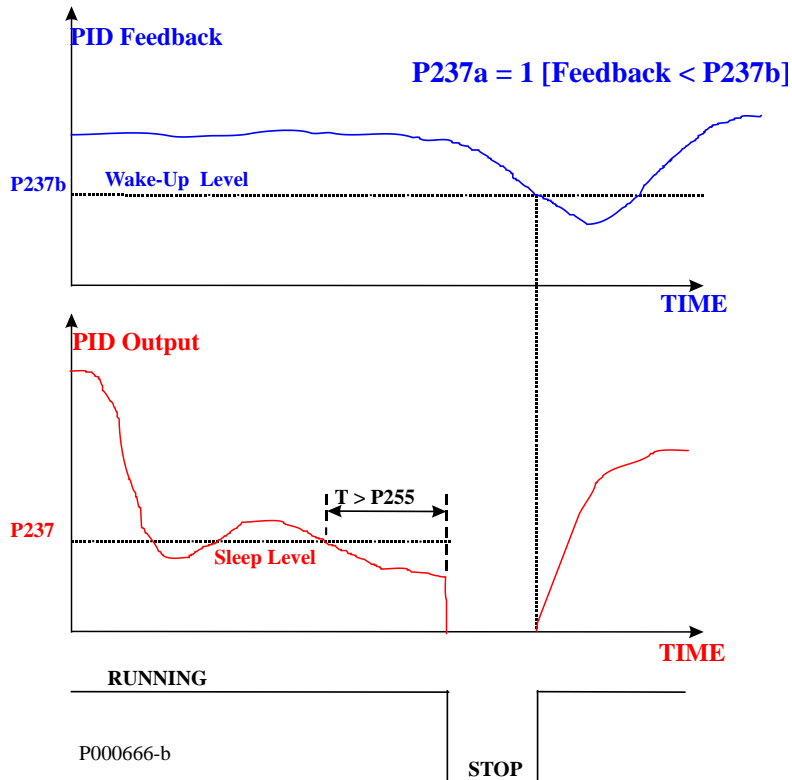

Figure 30: PID Sleep and Wake-up Mode when P237a is set to 1

**P238 Max. Value of Integral Term**

|             |                 |   |                     |
|-------------|-----------------|---|---------------------|
| <b>P238</b> | <b>Range</b>    | 0 ÷ 10000   | -100.00 ÷ +100.00 % |
|             | <b>Default</b>  | 10000   | +100.00 %           |
|             | <b>Level</b>    | ENGINEERING   |                     |
|             | <b>Address</b>  | 838   |                     |
|             | <b>Function</b> | This is the max. allowable value of the integral term. It is to be considered <u>as an absolute value</u> ; the output value resulting from the integral term ranges from + P238 to - P238. |                     |

**P239 Max. Value of Derivative Term**

|             |                 |  |                     |
|-------------|-----------------|--|---------------------|
| <b>P239</b> | <b>Range</b>    | 0 ÷ 10000  | -100.00 ÷ +100.00 % |
|             | <b>Default</b>  | 10000  | +100.00 %           |
|             | <b>Level</b>    | ENGINEERING  |                     |
|             | <b>Address</b>  | 839  |                     |
|             | <b>Function</b> | This is the max. allowable value of the derivative term; it is to be considered as <u>an absolute value</u> ; the output value resulting from the derivative term ranges from + <b>P239</b> to – <b>P239</b> . |                     |

**P240 PID Proportional Constant**

|             |                 |   |            |
|-------------|-----------------|---|------------|
| <b>P240</b> | <b>Range</b>    | 0 ÷ 65000   | 0 ÷ 65.000 |
|             | <b>Default</b>  | 1000  | 1.000      |
|             | <b>Level</b>    | ENGINEERING   |            |
|             | <b>Address</b>  | 840   |            |
|             | <b>Function</b> | This is the value of the proportional coefficient. The PID regulator will use Kp resulting from the product of <b>P240</b> multiplied by <b>P241</b> (multiplicative factor). |            |

**P241 Multiplicative Factor of P240**

|             |                 |  |                               |
|-------------|-----------------|--|-------------------------------|
| <b>P241</b> | <b>Range</b>    | 0÷2  | 0: 1.0<br>1: 10.0<br>2: 100.0 |
|             | <b>Default</b>  | 0  | 0: 1.0                        |
|             | <b>Level</b>    | ENGINEERING  |                               |
|             | <b>Address</b>  | 841  |                               |
|             | <b>Function</b> | Multiplicative factor of the proportional coefficient.<br>This is used to obtain a wider range for the proportional coefficient used in PID regulator and ranging from 0.000 to 6500.0.<br>Supposing that the default values are used for <b>P240</b> and <b>P241</b> , the proportional coefficient used in the PID regulator is unitary: in case an error of 1% occurs between the reference and the controlled variable, the proportional term, representing one of the three values of the regulator output, will be 1%. |                               |

**P242 PID Integral Time (Multiples of P244)**

|             |                 |   |                               |
|-------------|-----------------|---|-------------------------------|
| <b>P242</b> | <b>Range</b>    | 0 ÷ 65000   | 0: Disabled ÷ 65000 * Tc (ms) |
|             | <b>Default</b>  | 500   | 500* Tc (ms)                  |
|             | <b>Level</b>    | ENGINEERING   |                               |
|             | <b>Address</b>  | 842   |                               |
|             | <b>Function</b> | <b>Ti</b> constant dividing the integral term of PID regulator:<br><b>Ki = 1/Ti = 1/(P242*Ts)</b><br>It is expressed in <u>sampling time units Ts</u> (see <b>P244</b> ). If this parameter is set to zero, the integral action is cancelled. |                               |

**P243 PID Derivative Time (Multiples of P244)**

|             |                 |   |                      |
|-------------|-----------------|---|----------------------|
| <b>P243</b> | <b>Range</b>    | 0 ÷ 65000   | 0 ÷ 65.000 * Tc (ms) |
|             | <b>Default</b>  | 0   | 0*Tc (ms)            |
|             | <b>Level</b>    | ENGINEERING   |                      |
|             | <b>Address</b>  | 843   |                      |
|             | <b>Function</b> | Constant multiplying the derivative term of PID regulator. If this parameter is set to zero, the derivative action is disabled. |                      |

**P244 Cycle Time of PID Regulator: Tc**

|             |                 |  |              |
|-------------|-----------------|--|--------------|
| <b>P244</b> | <b>Range</b>    | 5 ÷ 65000  | 0 ÷ 65000 ms |
|             | <b>Default</b>  | 5  | 5 ms         |
|             | <b>Level</b>    | ENGINEERING  |              |
|             | <b>Address</b>  | 844  |              |
|             | <b>Function</b> | This parameter sets the cycle time of PID regulator. It is expressed in ms (multiples of 5 only). Example: if <b>P244</b> = 1000 ms, the PID regulator cycle will be executed every second, and the output will be refreshed every second as well. |              |

**P245 Min. Value of PID Reference**

|             |                 |   |          |
|-------------|-----------------|---|----------|
| <b>P245</b> | <b>Range</b>    | -20000 ÷ +20000   | ±200.00% |
|             | <b>Default</b>  | 0   | 0.00%    |
|             | <b>Level</b>    | ENGINEERING   |          |
|             | <b>Address</b>  | 845   |          |
|             | <b>Function</b> | This parameter defines the min. allowable value of the PID reference. The PID references are to be considered as percentage values. If analog references are selected, <b>P245</b> relates to the minimum value of the selected analog input. Example: Select AIN1 analog input as the PID reference and suppose that its max. and min. values are +10V and -10V respectively. If <b>P245</b> is -50%, this means that the PID reference will be saturated at -50% for voltage values lower than -5V. |          |

**P246 Max. Value of PID Reference**

|             |                 |  |          |
|-------------|-----------------|--|----------|
| <b>P246</b> | <b>Range</b>    | -20000 ÷ +20000  | ±200.00% |
|             | <b>Default</b>  | +10000   | +100.00% |
|             | <b>Level</b>    | ENGINEERING  |          |
|             | <b>Address</b>  | 846  |          |
|             | <b>Function</b> | This parameter defines the max. allowable value of the PID reference. See the description of <b>P245</b> . |          |

**P247 Min. Value of PID Feedback**

|             |                 |   |          |
|-------------|-----------------|---|----------|
| <b>P247</b> | <b>Range</b>    | -20000 ÷ +20000   | ±200.00% |
|             | <b>Default</b>  | 0   | 0.00%    |
|             | <b>Level</b>    | ENGINEERING   |          |
|             | <b>Address</b>  | 847   |          |
|             | <b>Function</b> | This parameter defines the min. allowable value of the PID feedback. See the description of <b>P245</b> . |          |

**P248 Max. Value of PID Feedback**

|             |                 |   |          |
|-------------|-----------------|---|----------|
| <b>P248</b> | <b>Range</b>    | -20000 ÷ +20000   | ±200.00% |
|             | <b>Default</b>  | +10000  | +100.00% |
|             | <b>Level</b>    | ENGINEERING   |          |
|             | <b>Address</b>  | 848   |          |
|             | <b>Function</b> | This parameter defines the max. allowable value of the PID feedback. See the description of <b>P245</b> . |          |

**P249 PID Reference Ramp Up Time**

|             |                 |   |                         |
|-------------|-----------------|---|-------------------------|
| <b>P249</b> | <b>Range</b>    | 0 ÷ 32700   | Function of <b>P251</b> |
|             | <b>Default</b>  | 0   | 0 s                     |
|             | <b>Level</b>    | ENGINEERING   |                         |
|             | <b>Address</b>  | 849   |                         |
|             | <b>Function</b> | This parameter defines the ramp up time of the PID regulator reference from 0% to the max. allowable absolute value (max. { <b>P245</b> , <b>P246</b> }). |                         |

**P250 PID Reference Ramp Down Time**

|             |                 |   |                         |
|-------------|-----------------|---|-------------------------|
| <b>P250</b> | <b>Range</b>    | 0 ÷ 32700   | Function of <b>P251</b> |
|             | <b>Default</b>  | 0   | 0 s                     |
|             | <b>Level</b>    | ENGINEERING   |                         |
|             | <b>Address</b>  | 850   |                         |
|             | <b>Function</b> | This parameter defines the ramp down time of the PID regulator reference, from max. allowable value (max. { <b>P245</b> , <b>P246</b> }) to 0%. |                         |

**P251 Unit of measure of PID Ramp**

|             |                 |   |  |
|-------------|-----------------|---|--|
| <b>P251</b> | <b>Range</b>    | 0 ÷ 3   | 0: 0.01 s<br>1: 0.1 s<br>2: 1.0 s<br>3: 10.0 s |
|             | <b>Default</b>  | 1   | 1: 0.10 s                                      |
|             | <b>Level</b>    | ENGINEERING   |  |
|             | <b>Address</b>  | 851   |  |
|             | <b>Function</b> | This parameter defines the unit of measure for the PID reference ramp times. It defines the unit of measure for the time of the third ramp of the PID reference <b>P249</b> and <b>P250</b> , so that the allowable range becomes 0s – 327000s. |  |

Example:

| <b>P251</b> |        | <b>Range P249 – P250</b> |          |
|-------------|--------|--------------------------|----------|
| Value       | Coding | Min.                     | Max.     |
| 0           | 0.01 s | 0                        | 327.00 s |
| 1           | 0.1s   | 0                        | 3270.0 s |
| 2           | 1.0 s  | 0                        | 32700 s  |
| 3           | 10.0 s | 0                        | 327000 s |



**NOTE**

Factory-setting: the PID reference ramp is zero; if a given ramp time is set up, the ramp will be rounded off (50% at the beginning and at the end of the ramp). See parameters **P252** and **P253**.

**P252 PID Ramp Start Rounding Off**

|             |                 |  |            |
|-------------|-----------------|--|------------|
| <b>P252</b> | <b>Range</b>    | 0 ÷ 100  | 0 % ÷ 100% |
|             | <b>Default</b>  | 50   | 50%        |
|             | <b>Level</b>    | ENGINEERING  |            |
|             | <b>Address</b>  | 852  |            |
|             | <b>Function</b> | This parameter sets the time period of the rounding off applied to the first stage of the ramps. It is expressed as a percentage of the ramp up/down time.<br>Example: ramp up of 5sec.: <b>P252</b> = 50% means that the speed reference is limited in acceleration for the first 2.5 sec of the ramp up. |            |



**NOTE** When **P252** is used, the preset ramp time is increased by  $(P252\%)/2$ .

**P253 PID Ramp End Rounding Off**

|             |                 |   |            |
|-------------|-----------------|---|------------|
| <b>P253</b> | <b>Range</b>    | 0 ÷ 100   | 0 % ÷ 100% |
|             | <b>Default</b>  | 50  | 50%        |
|             | <b>Level</b>    | ENGINEERING   |            |
|             | <b>Address</b>  | 853   |            |
|             | <b>Function</b> | As <b>P252</b> , but <b>P253</b> sets the rounding off applied at the end of the ramps. |            |



**NOTE** When **P253** is used, the preset ramp time is increased by  $(P253\%)/2$ .

**P254 Integral Term Activation Threshold**

|             |                 |   |                |
|-------------|-----------------|---|----------------|
| <b>P254</b> | <b>Range</b>    | 0.0 ÷ 5000  | 0.0 % ÷ 500.0% |
|             | <b>Default</b>  | 0   | 0.0 %          |
|             | <b>Level</b>    | ENGINEERING   |                |
|             | <b>Address</b>  | 854   |                |
|             | <b>Function</b> | This parameter sets a threshold value below which the integrator is kept to zero. It has effect only when the PID regulator is used as a reference corrector or generator.<br>In this case, the threshold percentage value refers to the max. speed (or torque) absolute value set for the active motor.<br>The integral term is not calculated when the speed (or torque) percentage value expressed as an absolute value is lower than the value set in <b>P254</b> .<br>If <b>P254</b> is set to zero, the integrator is always activated. |                |

**P255 START Disable Delay with PID Out=P237**

|             |                 |  |                            |
|-------------|-----------------|--|----------------------------|
| <b>P255</b> | <b>Range</b>    | 0 ÷ 60000  | 0: Disabled<br>1 ÷ 60000 s |
|             | <b>Default</b>  | 0  | 0: Disabled                |
|             | <b>Level</b>    | ENGINEERING  |                            |
|             | <b>Address</b>  | 855  |                            |
|             | <b>Function</b> | <p>This parameter sets the max. time for the drive operation when the PID regulator output continuously operates at its min. value (<b>P237</b>).</p> <p>If this is true for a time equal to the time set in <b>P255</b>, the drive is automatically put on stand-by until</p> <p>1) the PID output value exceeds the min. value (if <b>P237a</b>=Disabled);</p> <p>2) the Feedback or the Error drops below the Wake-up level in <b>P237b</b> (if <b>P237a</b>=1 or =3 respectively);</p> <p>3) when the Feedback or the Error exceeds the Wake-up level in <b>P237b</b> (if <b>P237a</b>=2 or =4 respectively).</p> <p>If <b>C294</b> is set as External Out or <b>P255</b> is set to zero, this function is disabled.</p> |                            |

**P256 PID Output Gradient Limit**

|             |                 |  |               |
|-------------|-----------------|--|---------------|
| <b>P256</b> | <b>Range</b>    | 1 ÷ 65000  | 1 ÷ 65000msec |
|             | <b>Default</b>  | 1  | 1msec         |
|             | <b>Level</b>    | ENGINEERING  |               |
|             | <b>Address</b>  | 856  |               |
|             | <b>Function</b> | <p>This parameter limits the max. acceleration for the PID regulator output. The max. acceleration for the PID regulator output is equal to 100% / <b>P256</b> [%/msec].</p> |               |

**P257 Gain for PID Measure Scaling**

|             |                 |  |                |
|-------------|-----------------|--|----------------|
| <b>P257</b> | <b>Range</b>    | 0 ÷ 32000  | 0.000 ÷ 32.000 |
|             | <b>Default</b>  | 1  | 1.000          |
|             | <b>Level</b>    | ENGINEERING  |                |
|             | <b>Address</b>  | 857  |                |
|             | <b>Function</b> | <p>Gain for the scaling of PID measures <b>M023 ÷ M025</b>.</p> <p>This gain has effect only on the measures above. It does not affect the PID operation.</p> <p>This parameter allows scaling if you want to display PID measures with a different unit of measure:</p> <p><b>M023 = M020 * P257</b></p> <p><b>M024 = M021 * P257</b></p> |                |

**P260 Anti Wind-Up Gain**

|             |                 |  |             |
|-------------|-----------------|--|-------------|
| <b>P260</b> | <b>Range</b>    | 0 ÷ 100  | 0.00 ÷ 1.00 |
|             | <b>Default</b>  | 100  | 1.00        |
|             | <b>Level</b>    | ENGINEERING  |             |
|             | <b>Address</b>  | 860  |             |
|             | <b>Function</b> | <p>Value of the Anti Wind-Up coefficient that freezes the integral term of the PID when its output is being saturated (see Anti-windup).</p> <p>When leaving <b>P260</b>=1.00, Anti Wind-Up is complete (<math>I \leftarrow OUT_{sat} - P - D</math>).</p> <p>If <b>P260</b>=0.00, Anti Wind-Up is inhibited (the integral term reaches the value of <math>\pm P238</math> based on the error sign).</p> <p>Intermediate values for <b>P260</b> give intermediate effects.</p> |             |

## 25. PID2 PARAMETERS MENU

### 25.1. Overview

---

This menu defines the parameters of the digital regulator PID2 as well as the parameters used in 2-zone mode.

To activate the PID2 regulator, set **C291a = 7: 2 PID** (PID CONFIGURATION MENU).

Once activated, the PID2 regulator has the same functionality and operates in line with the standard PID (PID PARAMETERS MENU). The output of the standard PID regulator is algebraically summed with the output of the PID2 regulator.

Add "200" to the parameter codes pertaining to the standard PID to obtain the relevant parameter codes for PID2. Example: **P236** for standard PID corresponds to **P436** for PID2.

To enable the 2-zone mode, set **C291a = 5: 2-Zone MIN** or **6: 2-Zone MAX** (PID CONFIGURATION MENU).

Once the 2-zone mode is enabled, the standard PID regulator operates on the system with the larger error (minimum feedback in respect to its reference, **2-Zone MIN**) or with the smaller error (maximum feedback in respect to its reference, **2-Zone MAX**).

In 2-zone mode, parameters **P236..P260** pertain to the system where the error results from the reference selected with **C285** and from the feedback selected with **C288**, whilst parameters **P436..P460** pertain to the system where the error results from the reference selected with **C286** and from the feedback selected with **C289**.



**NOTE** The PID2 regulator is disabled when operating in 2-zone mode.

Please refer to the block diagram in Figure 64.

## 25.2. List of Parameters P436 to P460

Table 45: List of parameters P436 to P460

| Parameter    | FUNCTION   | User Level  | DEFAULT VALUES | MODBUS Address |
|--------------|--|-------------|----------------|----------------|
| <b>P436</b>  | Max. value of PID2 output                            | ENGINEERING | +100.00%       | 1346           |
| <b>P437</b>  | Min. value of PID2 output                            | ENGINEERING | -100.00%       | 1347           |
| <b>P437a</b> | Wake-up Mode   | ENGINEERING | 0: [Disabled]  | 1282           |
| <b>P437b</b> | Wake-up Level  | ENGINEERING | 0.00%          | 1283           |
| <b>P438</b>  | Max. value of PID2 integral term                     | ENGINEERING | +100.00%       | 1348           |
| <b>P439</b>  | Max. value of PID2 derivative term                   | ENGINEERING | +100.00%       | 1349           |
| <b>P440</b>  | PID2 proportional constant                           | ENGINEERING | 1.000          | 1350           |
| <b>P441</b>  | Multiplicative factor of <b>P440</b>                 | ENGINEERING | 0:1.0          | 1351           |
| <b>P442</b>  | PID2 Integral time (multiples of <b>P444</b> )       | ENGINEERING | 500*Tc (ms)    | 1352           |
| <b>P443</b>  | PID2 Derivative time (multiples of <b>P444</b> )     | ENGINEERING | 0*Tc (ms)      | 1353           |
| <b>P444</b>  | Cycle time of PID2 regulator: Tc                     | ENGINEERING | 5 ms           | 1354           |
| <b>P445</b>  | Min. allowable value of PID2 reference               | ENGINEERING | 0.00%          | 1355           |
| <b>P446</b>  | Max. allowable value of PID2 reference               | ENGINEERING | +100.00%       | 1356           |
| <b>P447</b>  | Min. allowable value of PID2 feedback                | ENGINEERING | 0.00%          | 1357           |
| <b>P448</b>  | Max. allowable value of PID2 feedback                | ENGINEERING | +100.00%       | 1358           |
| <b>P449</b>  | PID2 reference ramp up time                          | ENGINEERING | 0 s            | 1359           |
| <b>P450</b>  | PID2 reference ramp down time                        | ENGINEERING | 0 s            | 1360           |
| <b>P451</b>  | Unit of measure of PID2 ramp                         | ENGINEERING | 1: [0.1s]      | 1361           |
| <b>P452</b>  | PID2 ramp start rounding off                         | ENGINEERING | 50%            | 1362           |
| <b>P453</b>  | PID2 ramp end rounding off                           | ENGINEERING | 50%            | 1363           |
| <b>P454</b>  | Integral term activation threshold                   | ENGINEERING | 0.00%          | 1364           |
| <b>P455</b>  | <b>START</b> Disable delay with PID Out= <b>P437</b> | ENGINEERING | 0: [Disabled]  | 1284           |
| <b>P456</b>  | PID2 output gradient limit                           | ENGINEERING | 1 ms           | 1368           |
| <b>P457</b>  | Gain for PID2 measure scaling                        | ENGINEERING | 1.000          | 1369           |
| <b>P460</b>  | Gain for Anti Wind-Up                                | ENGINEERING | 1.00           | 1370           |



**NOTE** Parameters **P437a**, **P437b** and **P455** are overridden if the Two PIDs mode is selected with “summed outputs” (**C291a = 7: 2 PID** and **C171a = 0: Disabled**).

## 26. DIGITAL OUTPUTS MENU

### 26.1. Overview

The Digital Outputs menu includes the parameters allowing configuring the drive digital outputs (MDO1, MDO2, MDO3 and MDO4).



**NOTE**

Relay digital output MDO4 is allocated to the **Safe Torque Off (STO)** function and cannot be configured by the user.

The MDO4 digital output may be configured only after deactivating the Safe Torque Off function (please refer to the Sinus Penta's Installation Guide).



**NOTE**

The Digital Outputs menu may be accessed only if the user level is **ADVANCED** or **ENGINEERING**.



**NOTE**

For a detailed hardware description of the digital outputs, please refer to the Sinus Penta's Installation Guide.



**NOTE**

MDO1 digital output can be programmed only if the frequency output is not set up (**P200** = Disable; see the **ANALOG AND FREQUENCY OUTPUTS MENU**).



**NOTE**

XMDI digital outputs (values from 13 to 20 in the parameters relating to the control functions) can be set up only after setting XMDI/O in parameter **R023**.

#### 26.1.1. FACTORY SETTINGS

The factory settings are as follows:

MDO1 is a zero speed relay (it energizes when a preset threshold is exceeded).

MDO2 controls an electromechanical brake used for crane applications (it energizes to release the brake).

MDO3 de-energizes (fail-safe logic) in case of "Inverter Alarm".

MDO4 energizes when the drive is running and is enabling the power stage ("Inverter Run OK" condition).

#### 26.1.2. STRUCTURE OF THE DIGITAL OUTPUTS

A digital output is composed of two logic blocks allowing data processing before actuating the actual digital output. Block 2 depends on the settings in parameters **P277a (P286a, P295a, P304a)**.

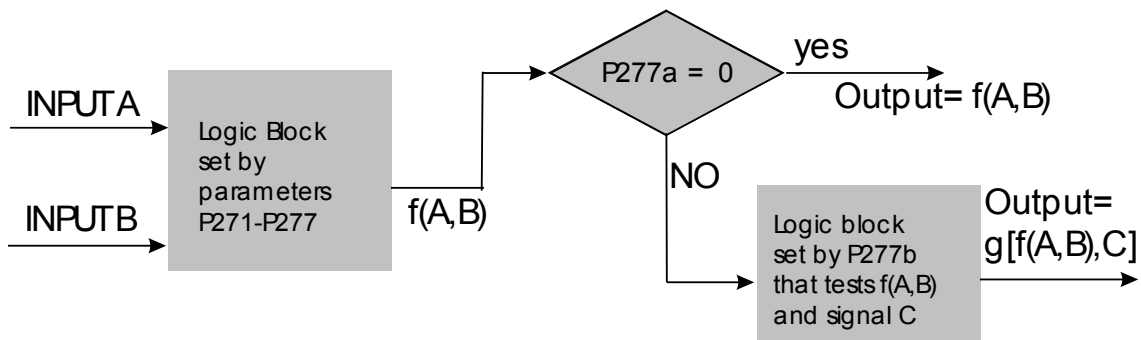

P000659-b

Figure 31: MDO block-diagram

**Operating modes set in MDO1 (2,3,4) Digital Output: P270, (P279, P288, P297)**

The user can select one of the following operating modes:

**Table 46: Digital Output Mode**

|                       |  |
|-----------------------|--|
| <b>DISABLE</b>        | The selected digital output is disabled.   |
| <b>DIGITAL</b>        | The digital output depends on a selected digital signal and on the logic output function (True/False).<br>See Examples 1 and 2.  |
| <b>DOUBLE DIGITAL</b> | The digital output depends on 2 selected digital signals, on the logic function calculating the output value and on the logic output function (True/False).  |
| <b>ANALOG</b>         | The digital output depends on a selected analog variable, which is tested through Test A and Test B, thus obtaining 2 digital signals; starting from their value, the selected logic function calculates the output value, whereas the True/False logic output function calculates the end value.<br>See Example 3.  |
| <b>DOUBLE ANALOG</b>  | The digital outputs depends on 2 selected analog variables: Test A is performed for variable A, whilst Test B is performed for variable B, thus obtaining 2 digital signals; starting from their value, the selected logic function calculates the output value, whereas the logic output function True/False calculates the end value.  |
| <b>DOUBLE FULL</b>    | As DOUBLE ANALOG or DOUBLE DIGITAL mode, but both digital signals and analog variables can be selected.<br>If you select a digital signal, its value (TRUE or FALSE) is used to calculate the selected logic function.<br>If you select an analog variable, the test selected for this variable is performed, and its result (TRUE or FALSE) is used to calculate the selected logic function. |
| <b>BRAKE (*)</b>      | As ABS BRAKE below, although the selected variables are not expressed as absolute values, but depend on the selected tests.  |
| <b>ABS BRAKE (*)</b>  | The ABS BRAKE mode allows controlling the electromechanical brake of a motor used for lifting applications. The ABS BRAKE mode is applied by selecting the measured (or estimated) speed value [A71] as the first variable, and the output torque [A81] as the second variable.<br>Variables are considered as absolute values.<br>See Example 4.  |
| <b>ABS LIFT (*)</b>   | As ABS BRAKE, but the brake unlocks (digital output open) when a given torque value is attained, which is automatically determined based on the last torque value required in the previous stroke.   |
| <b>PWM MODE</b>       | The PWM mode may be selected for digital outputs MDO1 and MDO2 only (it cannot be selected for relay digital outputs MDO3 and MDO4).<br>The digital output becomes a low-frequency PWM output with a duty-cycle proportional to the value of the selected analog output.<br>See Example 5.   |

(\*) The activation and deactivation of the outputs programmed as **BRAKE**, **ABS BRAKE** and **ABS LIFT** is affected also by other conditions depending on the drive status. Namely:

|                     |  |
|---------------------|--|
| <b>Activation</b>   | Conditions to be considered in logic AND with the following programmed functions: <ul style="list-style-type: none"> <li>• Drive accelerating or in pre-tensioning mode (see BRIDGE CRANE MENU).</li> <li>• Drive running, no alarm triggered</li> </ul>   |
| <b>Deactivation</b> | Conditions to be considered in logic OR with the following programmed functions: <ul style="list-style-type: none"> <li>• Drive not running or locked due to an alarm condition</li> <li>• Drive in tracking error mode (see ENCODER/FREQUENCY INPUTS MENU), unless parameter <b>C303</b> is set to NO (see BRIDGE CRANE MENU).</li> </ul> |

**Variable A Selected for MDO1 (2,3,4): P271, (P280, P289, P298)**

This selects the digital signal or the analog variable used for Test A (set with **P273/P282/P291/P300**). The whole list of the selectable items and their description appears at the end of this section (see Table 47). If a digital signal is selected, Test A is not performed: therefore, the comparison value for Test A (set with **P275/P284/P293/P302**) has no meaning.

**NOTE**

This parameter can be accessed only if the operating mode of the digital output concerned is other than zero. Example: MDO1 **P270**≠0.

**Variable B selected for MDO1 (2,3,4): P272, (P281, P290, P299)**

This selects a different digital signal or the analog variable used for Test B (set with **P274/P283/P292/P301**). The whole list of the selectable items and their description appears at the end of this section (see Table 47). If a digital signal is selected, Test B is not performed: therefore, the comparison value for Test B (set with **P276/P285/P294/P303**) has no meaning.

**NOTE**

Parameter **P272** cannot be accessed when the digital output operating mode is 1: DIGITAL or 3: ANALOG.

Example: MDO1 **P270**=1 OR **P270**=3.

**Table 47: List of the selectable digital inputs and analog outputs**

Selectable digital signals (BOOLEAN):

| Selectable Value    | Description   |
|---------------------|---|
| D0: Disable         | Always FALSE: 0   |
| D1: Run Ok          | Drive running (no standby)                                    |
| D2: Ok On           | Inverter ok: no alarms tripped                                |
| D3: Alarm           | Drive alarm tripped   |
| D4: Run ALR         | Drive KO: alarm tripped when the drive is running             |
| D5: Fwd Run         | Speed (measured or estimated) higher than +0.5 rpm            |
| D6: Rev Run         | Speed (measured or estimated) lower than -0.5 rpm             |
| D7: Lim. MOT        | Drive in limiting mode operating as a motor                   |
| D8: Lim.GEN         | Drive in limiting mode operating as a generator               |
| D9: Limiting        | Drive in limiting mode (generator or motor)                   |
| D10: Prec. Ok       | Capacitor Precharge relay closure and command return test     |
| D11: PID MAX        | PID output max. saturation                                    |
| D12: PID MIN        | PID output min. saturation                                    |
| D13: MDI 1          | Selected MDI1 digital input (remote OR physical)              |
| D14: MDI 2          | Selected MDI2 digital input (remote OR physical)              |
| D15: MDI 3          | Selected MDI3 digital input (remote OR physical)              |
| D16: MDI 4          | Selected MDI4 digital input (remote OR physical)              |
| D17: MDI 5          | Selected MDI5 digital input (remote OR physical)              |
| D18: MDI 6          | Selected MDI6 digital input (remote OR physical)              |
| D19: MDI 7          | Selected MDI7 digital input (remote OR physical)              |
| D20: MDI 8          | Selected MDI8 digital input (remote OR physical)              |
| D21: Enable         | ENABLE function (remote AND physical)                         |
| D22: Enable SW      | ENABLE-SW function (remote AND physical)                      |
| D23: MDI 1 Delayed  | MDI1 Digital input (remote OR physical) DELAYED by MDI timers |
| D24: MDI 2 Delayed  | MDI2 Digital input (remote OR physical) DELAYED by MDI timers |
| D25: MDI 3 Delayed  | MDI3 Digital input (remote OR physical) DELAYED by MDI timers |
| D26: MDI 4 Delayed  | MDI4 Digital input (remote OR physical) DELAYED by MDI timers |
| D27: MDI 5 Delayed  | MDI5 Digital input (remote OR physical) DELAYED by MDI timers |
| D28: MDI 6 Delayed  | MDI6 Digital input (remote OR physical) DELAYED by MDI timers |
| D29: MDI 7 Delayed  | MDI7 Digital input (remote OR physical) DELAYED by MDI timers |
| D30: MDI 8 Delayed  | MDI8 Digital input (remote OR physical) DELAYED by MDI timers |
| D31: ENABLE Delayed | ENABLE function (remote AND physical) DELAYED by MDI timers   |
| D32: Trk.Err        | Speed tracking error:  SetPoint – Measure  > Error_Par        |

| Selectable Value        | Description  |
|-------------------------|--|
| D33: Fan Flt            | Fault of the cooling fan   |
| D34: Fbus C1            | Command 1 from fieldbus  |
| D35: Fbus C2            | Command 2 from fieldbus  |
| D36: Fbus C3            | Command 3 from fieldbus  |
| D37: Fbus C4            | Command 4 from fieldbus  |
| D38: FireMod            | Fire Mode function   |
| D39: Local              | LOCAL Mode   |
| D40: Speed OK           | Constant speed reference reached   |
| D41: Fan ON             | Fan activation command   |
| D42: XMDI1              | XMDI1 Auxiliary digital input  |
| D43: XMDI2              | XMDI2 Auxiliary digital input  |
| D44: XMDI3              | XMDI3 Auxiliary digital input  |
| D45: XMDI4              | XMDI4 Auxiliary digital input  |
| D46: XMDI5              | XMDI5 Auxiliary digital input  |
| D47: XMDI6              | XMDI6 Auxiliary digital input  |
| D48: XMDI7              | XMDI7 Auxiliary digital input  |
| D49: XMDI8              | XMDI8 Auxiliary digital input  |
| D50: MPL 1 Delayed      | Virtual digital input resulting from MPL1 output DELAYED from MPL Timers             |
| D51: MPL 2 Delayed      | Virtual digital input resulting from MPL2 output DELAYED from MPL Timers             |
| D52: MPL 3 Delayed      | Virtual digital input resulting from MPL3 output DELAYED from MPL Timers             |
| D53: MPL 4 Delayed      | Virtual digital input resulting from MPL4 output DELAYED from MPL Timers             |
| D54: OTM Elapsed        | Maintenance Operation Time elapsed   |
| D55: STM Elapsed        | Maintenance Supply Time elapsed  |
| D56: MDO 1 Delayed      | Virtual digital input resulting from MDO1 output DELAYED from MDO Timers             |
| D57: MDO 2 Delayed      | Virtual digital input resulting from MDO2 output DELAYED from MDO Timers             |
| D58: MDO 3 Delayed      | Virtual digital input resulting from MDO3 output DELAYED from MDO Timers             |
| D59: MDO 4 Delayed      | Virtual digital input resulting from MDO4 output DELAYED from MDO Timers             |
| D60: TFL1               | Timed flag TFL1  |
| D61: TFL2               | Timed flag TFL2  |
| D62: TFL3               | Timed flag TFL3  |
| D63: TFL4               | Timed flag TFL4  |
| D64: NTC Fault          | NTC Fault (heatsink temperature measurement)   |
| D65: Cumulative Warning | Logic OR of W40 (FAN FAULT), W50 (NTC FAULT), W48 (OT TIME OVER), W49 (ST TIME OVER) |
| D66: Dec to Stop        | Deceleration due to START opening or STOP activation                                 |
| D67: Reserved           |  |
| D68: Accelerating       | Motor accelerating   |
| D69: Decelerating       | Motor decelerating   |

Selectable analog variables:

| Selectable Value        | Full-scale Value | Kri   | Description                                     |
|-------------------------|------------------|-------|---|
| A70: GROUND             |                  |       | Analog 0 Volt                                   |
| A71: Speed              | 10000 rpm        | 1     | Motor speed                                     |
| A72: Spd REF.           | 10000 rpm        | 1     | Speed reference at constant speed               |
| A73: RampOut            | 10000 rpm        | 1     | Speed reference when ramps are over             |
| A74: MotFreq            | 1000.0 Hz        | 10    | Frequency produced by the drive                 |
| A75: MotCurr            | 5000.0 A         | 10    | Current RMS                                     |
| A76: OutVolt            | 2000.0 V         | 10    | Output voltage RMS                              |
| A77: Out Pow            | 1000.0 kW        | 10    | Output power                                    |
| A78: DC Vbus            | 2000.0 V         | 10    | DC-link voltage                                 |
| A79: Torq.REF           | 100.00 %         | 100   | Torque reference at constant speed              |
| A80: Torq.DEM           | 100.00 %         | 100   | Torque demand                                   |
| A81: Torq.OUT           | 100.00 %         | 100   | Estimation of the torque output                 |
| A82: Torq.LIM           | 100.00 %         | 100   | Torque limit setpoint                           |
| A83: PID REF            | 100.00 %         | 100   | PID reference at constant speed                 |
| A84: PID RMP            | 100.00 %         | 100   | PID reference when ramps are over               |
| A85: PID Err            | 100.00 %         | 100   | Error between PID reference and PID feedback    |
| A86: PID Fbk            | 100.00 %         | 100   | PID feedback                                    |
| A87: PID Out            | 100.00 %         | 100   | PID output                                      |
| A88: REF                | 100.00 %         | 100   | Analog input REF                                |
| A89: AIN1               | 100.00 %         | 100   | Analog input AIN1                               |
| A90: AIN2/Pt            | 100.00 %         | 100   | Analog input AIN2/PTC                           |
| A91: Encln              | 10000 rpm        | 1     | Speed read from encoder and used as a reference |
| A92: Pulseln            | 100.00 kHz       | 100   | Frequency input                                 |
| A93: Flux REF           | 1.0000 Wb        | 10000 | Flux reference at constant speed                |
| A94: Flux               | 1.0000 Wb        | 10000 | Active flux reference                           |
| A95: Iq REF             | 5000.0 A         | 10    | Current reference over axis q                   |
| A96: Id REF             | 5000.0 A         | 10    | Current reference over axis d                   |
| A97: Iq                 | 5000.0 A         | 10    | Current measure over axis q                     |
| A98: Id                 | 5000.0 A         | 10    | Current measure over axis d                     |
| A99: Volt Vq            | 2000.0 V         | 10    | Voltage over axis q                             |
| A100: Volt Vd           | 2000.0 V         | 10    | Voltage over axis d                             |
| A101: Cosine            | 100.00 %         | 100   | Waveform: Cosine                                |
| A102: Sine              | 100.00 %         | 100   | Waveform: Sine                                  |
| A103: Angle             | 100.00 %         | 100   | Electric angle of delivered Vu                  |
| A104: +10V              |                  |       | Analog +10 Volt                                 |
| A105: -10V              |                  |       | Analog -10 Volt                                 |
| A106: Flux Current      | 5000.0A          | 10    | Flux current                                    |
| A107: SqrWave           | 100.00 %         | 100   | Square wave                                     |
| A108: Saw Wave          | 100.00 %         | 100   | Saw wave  |
| A109: HtsTemp.          | 100.00 °C        | 100   | Heatsink temperature                            |
| A110: AmbTemp.          | 100.00 °C        | 100   | Ambient temperature                             |
| A111 ÷ A119: Reserved   |                  |       |   |
| A120: PT100_1           | 320.00 °C        | 100   | PT100 channel 1                                 |
| A121: PT100_2           | 320.00 °C        | 100   | PT100 channel 2                                 |
| A122: PT100_3           | 320.00 °C        | 100   | PT100 channel 3                                 |
| A123: PT100_4           | 320.00 °C        | 100   | PT100 channel 4                                 |
| A124: I2t%              | 100.00 %         | 100   | Motor thermal capacity                          |
| A125: XAIN4             | 100.00 %         | 100   | XAIN4 analog input                              |
| A126: XAIN5             | 100.00 %         | 100   | XAIN5 analog input                              |
| A127: OT Counter        | 320000h          | 1     | Maintenance Operation Time counter              |
| A128: ST Counter        | 320000h          | 1     | Maintenance Supply Time counter                 |
| A129: PID2 REF          | 100.00 %         | 100   | PID2 reference at constant speed                |
| A130: PID2 RMP          | 100.00 %         | 100   | PID2 reference when ramps are over              |
| A131: PID2 Fbk          | 100.00 %         | 100   | Error between PID2 reference and PID2 feedback  |
| A132: PID2 Err          | 100.00 %         | 100   | PID2 feedback                                   |
| A133: PID2 Out          | 100.00 %         | 100   | PID2 output                                     |
| A134: Torque Demand %   | 100.00 %         | 100   | Torque demand (percentage)                      |
| A135: Actual Current Iv | 5000.0A          | 10    | Output current Iv                               |
| A129: Reserved          |                  |       |   |

Minimum value = -3.2\*Full-scale value  
 Maximum value = 3.2\*Full-scale value  
 MODBUS value = Parameter value\*Kri

**Testing Variable A for MDO1 (2,3,4): P273, (P282, P291, P300)**

If an analog variable is selected, a logic TEST is performed to obtain a TRUE/FALSE Boolean signal. Seven different tests are available, that can be performed for selected variable A and its comparing value A:

**Table 48: Test functions**

|                            |  |
|----------------------------|--|
| GREATER THAN               | Selected variable > comparing value                  |
| GREATER THAN/EQUAL TO      | Selected variable ≥ comparing value                  |
| LOWER                      | Selected variable < comparing value                  |
| LOWER THAN/EQUAL TO        | Selected variable ≤ comparing value                  |
| ABS, GREATER THAN          | Absolute value (selected variable) > comparing value |
| ABS, GREATER THAN/EQUAL TO | Absolute value (selected variable) ≥ comparing value |
| ABS, LOWER                 | Absolute value (selected variable) < comparing value |
| ABS, LOWER THAN/EQUAL TO   | Absolute value (selected variable) ≤ comparing value |



**NOTE**

This parameter can be accessed only if the operating mode of the selected digital output is > 2. Example: MDO1 **P270**>2.

**Testing Variable B for MDO1 (2,3,4): P274, (P283, P292, P301)**

If an analog variable is selected, a logic TEST is performed to obtain a TRUE/FALSE Boolean signal. Seven different tests are available, that can be performed for selected variable B and its comparing value B (see Table 48).



**NOTE**

This parameter can be accessed only if the operating mode of the selected digital output is > 2 and < 9. Example: MDO1 2<**P270**<9.

**Reference threshold for P271 (P280, P289, P298) in MDO1: P275, (P284, P293, P302)**

This defines the comparing value of Test A with the first selected variable.



**NOTE**

This parameter can be accessed only if the operating mode of the selected digital output is > 2. Example: MDO1 **P270**>2.

**Reference threshold for P272 (P281, P290, P299) in MDO2 (3,4): P276, (P285, P294, P303)**

This defines the comparing value of Test B with the first selected variable.



**NOTE**

This parameter can be accessed only if the operating mode of the selected digital output is > 2. Example: MDO1 **P270**>2.

**MDO1 (2, 3, 4): Function Applied to the Result of Tests A and B: P277, (P286, P295, P304)**

A logic function is applied to the two Boolean signals obtained in order to obtain the output TRUE/FALSE Boolean signal.

Six different tests may be performed for variable (A) using the comparing value and variable (B).

**(A) OR (B):** The selected digital output is enabled when at least one of the two conditions below is true (this function also allows enabling the selected digital input based on one test only).

| <b>(A) OR (B)</b> |        |          |
|-------------------|--------|----------|
| Test A            | Test B | Output   |
| 0                 | 0      | <b>0</b> |
| 1                 | 0      | <b>1</b> |
| 0                 | 1      | <b>1</b> |
| 1                 | 1      | <b>1</b> |

**(A) SET (B) RESET Rising Edge**

**(A) RESET (B) SET Rising Edge**

**(A) SET (B) RESET Falling Edge**

**(A) RESET (B) SET Falling Edge**

The selected digital output is activated as the output of a Flip Flop Set Reset whose inputs are signal A and signal B. This function can be used in case of hysteresis.

The status of the input (Q<sub>n</sub>) depends on the previous value (Q<sub>n-1</sub>) and on the result of the two tests.

Signals A and B are considered only when passing from 0→1 (Rising Edge) or 1→0 (Falling Edge). Signal A and signal B may be used both as Set and Reset command.

Example: Suppose that the output enables only when the motor speed exceeds 50rpm and disables when the motor speed drops below 5 rpm. To do so, assign the first condition to Test A, representing the Set command for Flip Flop (P271 = Motor Speed, P273 >, P275 = 50rpm), and assign the second condition to Test B, representing the Reset command (P272 = Motor Speed, P274 <=, P276 = 5rpm). A more detailed example is given at the end of this section.

| <b>(A) SET (B) RESET Rising Edge</b> |                |                  |
|--------------------------------------|----------------|------------------|
| Test A (Set)                         | Test B (Reset) | Q <sub>n</sub>   |
| 0→1                                  | X              | <b>1</b>         |
| X                                    | 0→1            | <b>0</b>         |
| In any other case                    |                | Q <sub>n-1</sub> |

| <b>(A) RESET (B) SET Rising Edge</b> |              |                  |
|--------------------------------------|--------------|------------------|
| Test A (Reset)                       | Test B (Set) | Q <sub>n</sub>   |
| 0→1                                  | X            | <b>0</b>         |
| X                                    | 0→1          | <b>1</b>         |
| In any other case                    |              | Q <sub>n-1</sub> |

| <b>(A) SET (B) RESET Falling Edge</b> |                |                  |
|---------------------------------------|----------------|------------------|
| Test A (Set)                          | Test B (Reset) | Q <sub>n</sub>   |
| 1→0                                   | X              | <b>1</b>         |
| X                                     | 1→0            | <b>0</b>         |
| In any other case                     |                | Q <sub>n-1</sub> |

| <b>(A) RESET (B) SET Falling Edge</b> |              |                  |
|---------------------------------------|--------------|------------------|
| Test A (Reset)                        | Test B (Set) | Q <sub>n</sub>   |
| 1→0                                   | X            | <b>0</b>         |
| X                                     | 1→0          | <b>1</b>         |
| In any other case                     |              | Q <sub>n-1</sub> |

**(A) AND (B):** The selected digital output enables when both conditions are true.

| <b>(A) AND (B)</b> |        |        |
|--------------------|--------|--------|
| Test A             | Test B | Output |
| 0                  | 0      | 0      |
| 1                  | 0      | 0      |
| 0                  | 1      | 0      |
| 1                  | 1      | 1      |

**(A) XOR (B):** The selected digital output enables when either one condition or the other is true (but not when both conditions are true at a time).

| <b>(A) XOR (B)</b> |        |        |
|--------------------|--------|--------|
| Test A             | Test B | Output |
| 0                  | 0      | 0      |
| 1                  | 0      | 1      |
| 0                  | 1      | 1      |
| 1                  | 1      | 0      |

**(A) NOR (B):** The selected digital output enables when no condition is true. The NOR function between two variables corresponds to the AND of the same false variables, i.e.  $(A)NOR (B) = (/A) AND (/B)$ .

| <b>(A) NOR (B)</b> |        |        |
|--------------------|--------|--------|
| Test A             | Test B | Output |
| 0                  | 0      | 1      |
| 1                  | 0      | 0      |
| 0                  | 1      | 0      |
| 1                  | 1      | 0      |

**(A) NAND (B):** The selected digital output enables when no condition is true or when only one of the two conditions is true. The NAND function between two variables corresponds to the OR of the same false variables, i.e.  $(A)NAND (B) = (/A) OR (/B)$ .

| <b>(A) NAND (B)</b> |        |        |
|---------------------|--------|--------|
| Test 1              | Test 2 | Output |
| 0                   | 0      | 1      |
| 1                   | 0      | 1      |
| 0                   | 1      | 1      |
| 1                   | 1      | 0      |



**NOTE**

This parameter can be accessed only if the operating mode of the selected digital output is > 2 and <9. Example: MDO1 2<P270<9.

**Function applied to the result of f(A,B) C for MDO1 P277b, (P286b, P295b, P304b)**

Once the Boolean signal resulting from f(A,B) is obtained, an additional logic function can be applied to obtain the output TRUE//FALSE Boolean signal.  
If parameter **P277a** is disabled, the output of f(A,B) goes directly to the corresponding digital output; if parameter P277a is enabled, the output of the output of f(A,B) becomes one of the two inputs of the second programmed block.  
The user can choose one of the six Boolean tests above for the first variable - f(A,B) – and for the second variable (C).  
See Example 6.

**MDO1 (2,3,4): Logic applied to MDO1 (2,3,4): P278, (P287, P296, P305)**

The logic of the Boolean signal can be reversed at the end of the processing chain.  
The user can choose whether the logic level of the digital output is POSITIVE or NEGATIVE.  
(0) FALSE = a logic negation is applied (NEGATIVE logic)  
(1) TRUE = no negation is applied (POSITIVE logic)



**NOTE**

This parameter can be accessed only if the operating mode of the selected digital output is other than zero. Example: MDO1 **P270**≠0.

**26.2. Programmable Operating Modes (Diagrams)**

The diagrams shown in the figures illustrate the operating structure of MDO1 digital output; the remaining digital outputs (MDO2, MDO3, and MDO4) will follow the same logics, as implemented in the relevant parameters.

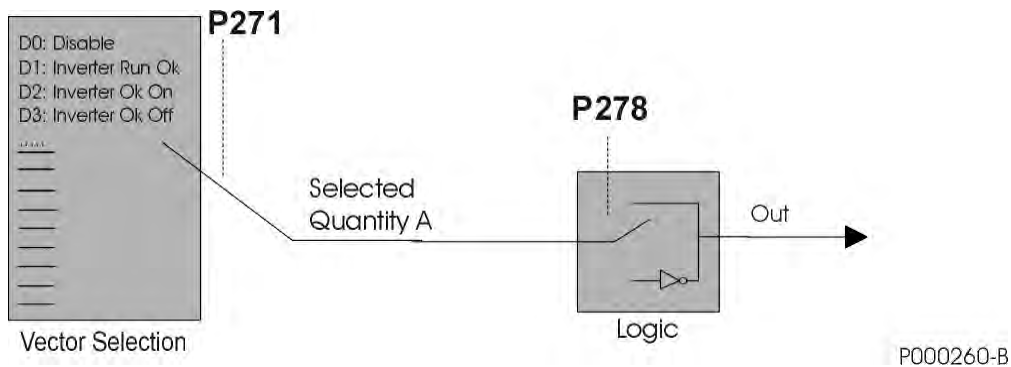

**Figure 32: DIGITAL Mode**

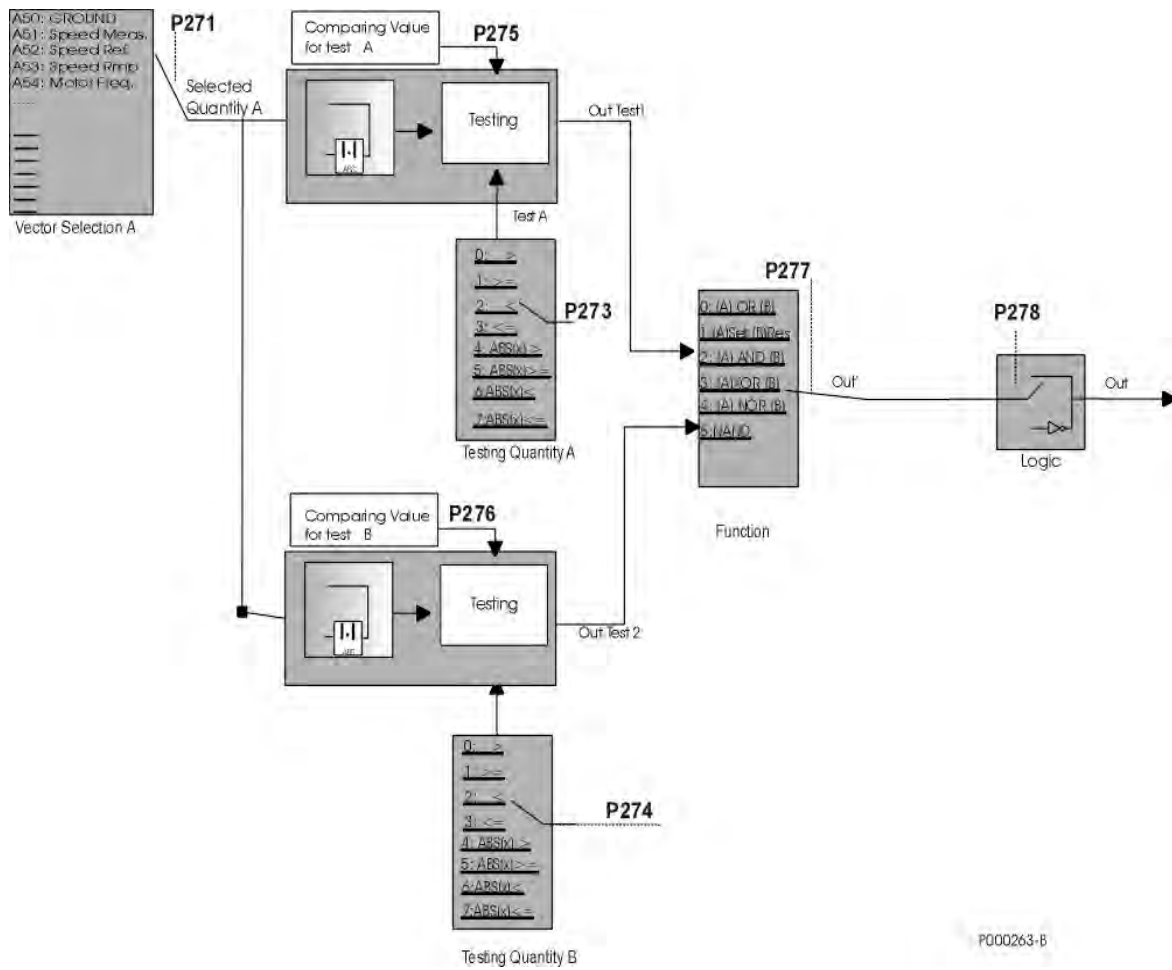

Figure 33: ANALOG Mode

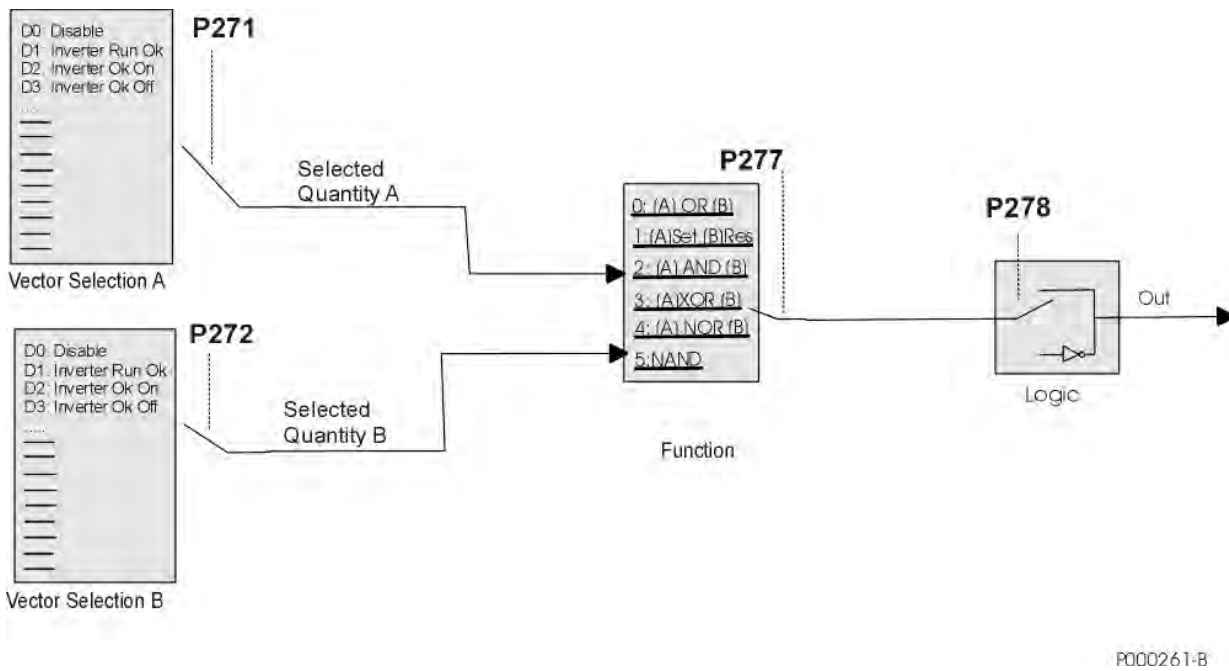
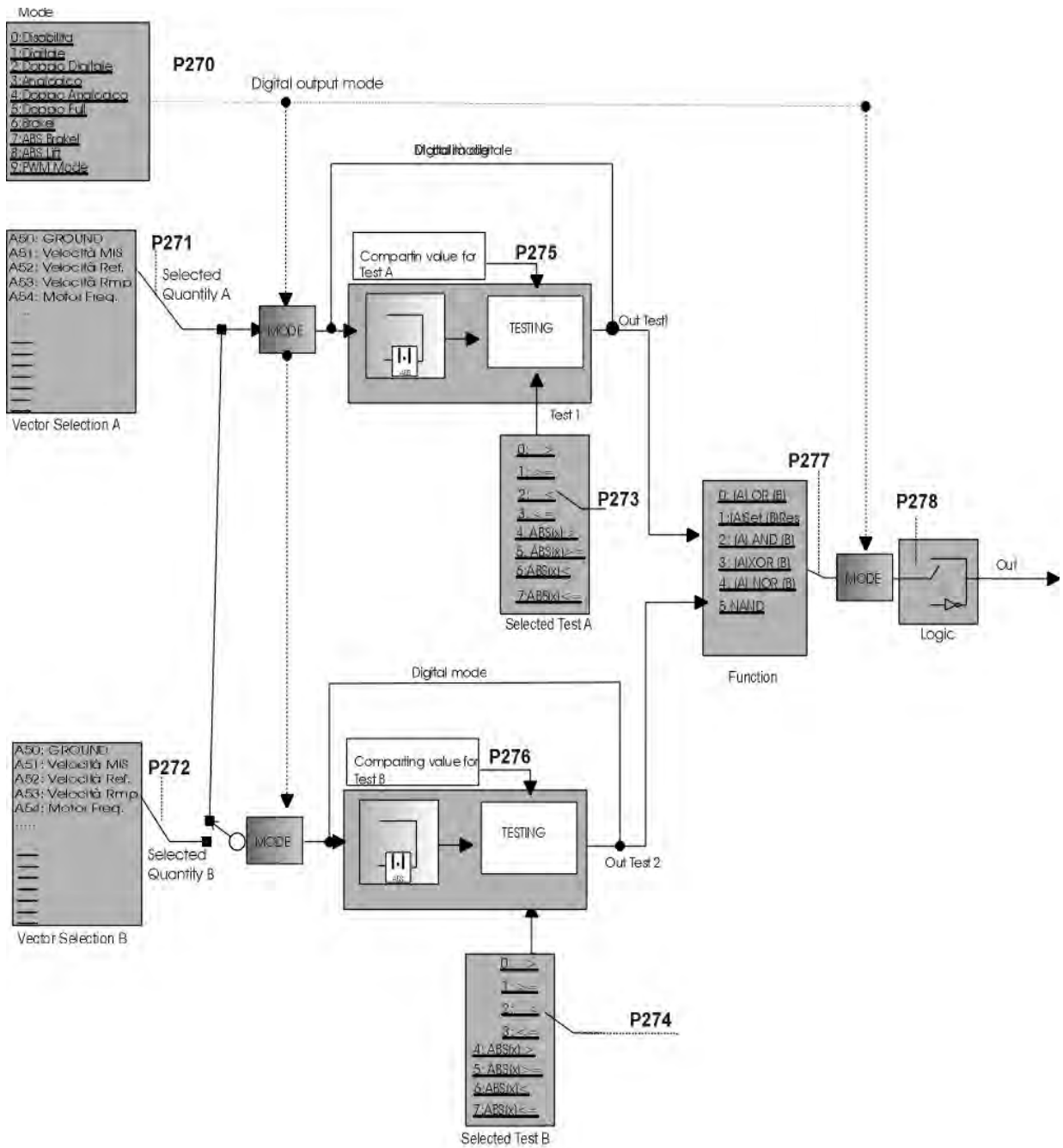

Figure 34: DOUBLE DIGITAL Mode



P000262-B

Figure 35: General structure of the parameterization of a digital output

## 26.3. Examples

---

This section illustrates some examples.  
 A table stating the setup of the parameters used is given for each example.  
 Parameters highlighted in grey have no effect due to their preset selection.

**Example 1: Digital output for Inverter Alarm digital command (MDO3 digital output default setting).**

**Table 49: MDO parameterization for PD Status OK**

|              |   |                    |
|--------------|---|--------------------|
| <b>P288</b>  | MDO3: Digital output mode                                 | DIGITAL            |
| <b>P289</b>  | MDO3: Variable A selection                                | D3: Inverter Alarm |
| <b>P290</b>  | MDO3: Variable B selection                                |                    |
| <b>P291</b>  | MDO3: Testing variable A                                  |                    |
| <b>P292</b>  | MDO3: Testing variable B                                  |                    |
| <b>P293</b>  | MDO3: Comparing value for Test A                          |                    |
| <b>P294</b>  | MDO3: Comparing value for Test B                          |                    |
| <b>P295</b>  | MDO3: Function applied to the result of the two tests     |                    |
| <b>P295a</b> | MDO3: Variable C selection                                | D0: Disabled       |
| <b>P295b</b> | MDO3: Function applied to the result of f(A,B) and C test |                    |
| <b>P296</b>  | MDO3: Output logic level                                  | FALSE              |

The digital output status depends on the Boolean variable “Inverter Alarm”, which is TRUE only when an alarm trips. This output is a fail-safe contact: the relay energizes if the drive is on and no alarms tripped.

**Example 2: Digital output for Drive Run OK digital command (MDO4 digital output default setting).**

**Table 50: MDO parameterization for drive Run OK**

|              |   |                  |
|--------------|---|------------------|
| <b>P297</b>  | MDO4: Digital output mode                                 | DIGITAL          |
| <b>P298</b>  | MDO4: Variable A selection                                | D1: Drive Run Ok |
| <b>P299</b>  | MDO4: Variable B selection                                |                  |
| <b>P300</b>  | MDO4: Testing variable A                                  |                  |
| <b>P301</b>  | MDO4: Testing variable B                                  |                  |
| <b>P302</b>  | MDO4: Comparing value for Test A                          |                  |
| <b>P303</b>  | MDO4: Comparing value for Test B                          |                  |
| <b>P304</b>  | MDO4: Function applied to the result of the two tests     |                  |
| <b>P295a</b> | MDO3: Variable C selection                                | D0: Disabled     |
| <b>P295b</b> | MDO3: Function applied to the result of f(A,B) and C test |                  |
| <b>P305</b>  | MDO4: Output logic level                                  | TRUE             |

The digital output status depends on the Boolean variable “Drive Run Ok”, which is TRUE only when the drive is modulating (IGBTs on).

**Example 3: Digital output for speed thresholds**

Suppose that a digital output energizes if the motor speed exceeds 100rpm as an absolute value, and de-energizes when the motor speed is lower than or equal to 20rpm (as an absolute value). Parameter P270 sets ABS mode, so that the selected variables are considered as absolute values. The condition “greater than” is selected for test A, and “lower than/equal to” is selected for test B.

**Table 51: MDO parameterization for speed thresholds**

|              |   |                               |
|--------------|---|-------------------------------|
| <b>P270</b>  | MDO1: Digital output mode                                 | DOUBLE ANALOG                 |
| <b>P271</b>  | MDO1: Variable A selection                                | A71: Speed MEA                |
| <b>P272</b>  | MDO1: Variable B selection                                | A71: Speed MEA                |
| <b>P273</b>  | MDO1: Testing variable A                                  | ABS(x) >                      |
| <b>P274</b>  | MDO1: Testing variable B                                  | ABS(x) ≤                      |
| <b>P275</b>  | MDO1: Comparing value for Test A                          | 100.00 rpm                    |
| <b>P276</b>  | MDO1: Comparing value for Test B                          | 20.00 rpm                     |
| <b>P277</b>  | MDO1: Function applied to the result of the two tests     | (A) Set (B) Reset Rising Edge |
| <b>P277a</b> | MDO1: Variable C selection                                | D0: Disabled                  |
| <b>P277b</b> | MDO1: Function applied to the result of f(A,B) and C test |                               |
| <b>P278</b>  | MDO1: Output logic level                                  | TRUE                          |

Both tests are performed over the motor speed; **P271**, **P272** are set to “motor speed”. The values of reference for the two tests are 100rpm and 20rpm; the function applied is Flip Flop Set Reset and the output is considered as a true logic. Test A is the Set signal of the Flip Flop and Test B is the Reset signal.

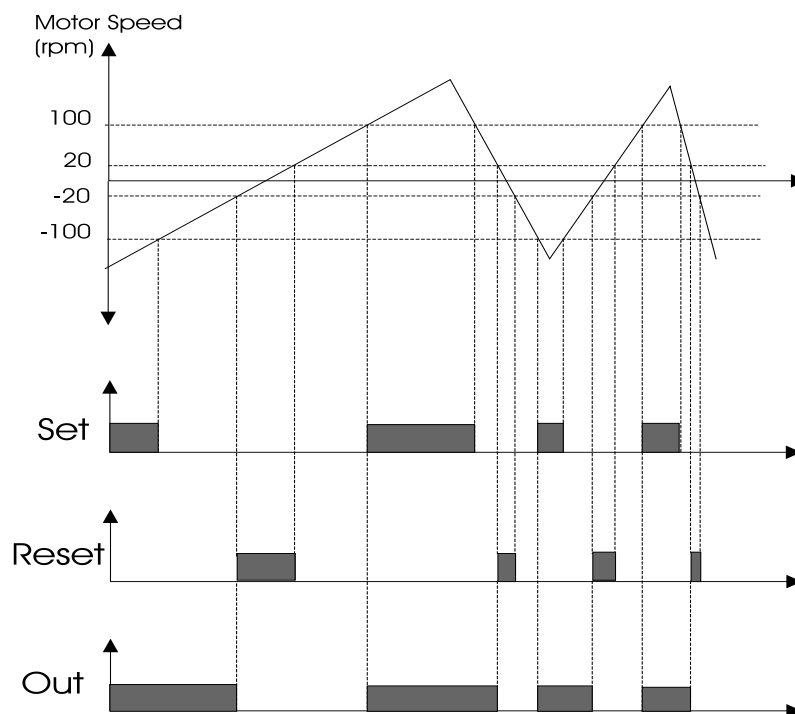

**Figure 36: Digital output for speed thresholds (example)**

**Example 4: Digital output for electromechanical brake for lifting applications (programming example related to MDO3 digital output).**

**Table 52: MDO parameterization for electromechanical brake command**

|              |   |                               |
|--------------|---|-------------------------------|
| <b>P288</b>  | MDO3: Digital output mode                                 | ABS BRAKE                     |
| <b>P289</b>  | MDO3: Variable A selection                                | A81: Torque Output            |
| <b>P290</b>  | MDO3: Variable B selection                                | A71: Speed MEA                |
| <b>P291</b>  | MDO3: Testing variable A                                  | >                             |
| <b>P292</b>  | MDO3: Testing variable B                                  | ≤                             |
| <b>P293</b>  | MDO3: Comparing value for Test A                          | 20.00%                        |
| <b>P294</b>  | MDO3: Comparing value for Test B                          | 50.00 rpm                     |
| <b>P295</b>  | MDO3: Function applied to the result of the two tests     | (A) Set (B) Reset Rising Edge |
| <b>P295a</b> | MDO3: Variable C selection                                | D0: Disabled                  |
| <b>P295b</b> | MDO3: Function applied to the result of f(A,B) and C test |                               |
| <b>P296</b>  | MDO3: Output logic level                                  | TRUE                          |

The digital output energizes only if no alarm trips. The torque demand is greater than **P302** = 20.00% (Set). The digital output de-energizes if an alarm trips or if the decelerating speed is lower than the speed value set in **P303** = 50rpm (Reset).

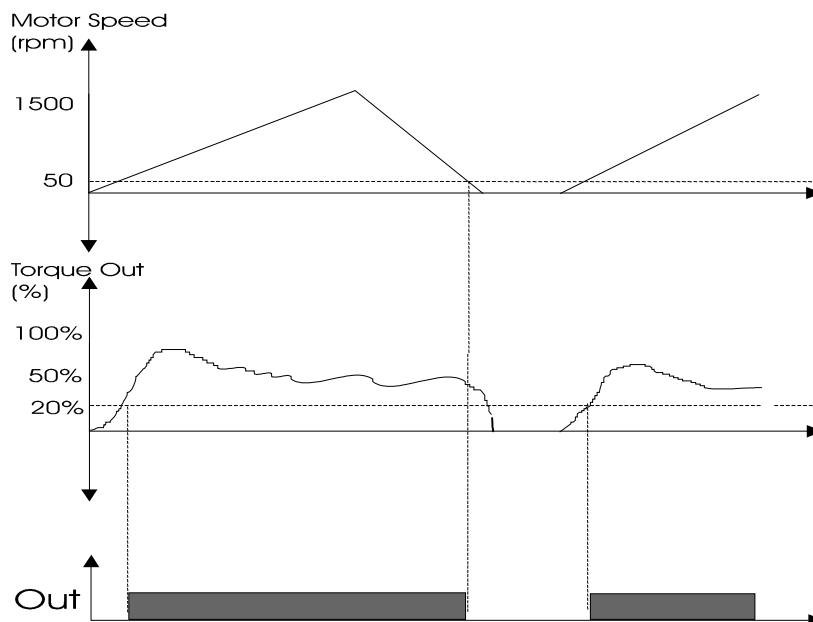

**Figure 37: Electromechanical brake command (example)**



**CAUTION**

Always use the NO contact of the digital output for the electromechanical brake command.



**NOTE**

For details about the electromechanical brake used for lifting applications, see also the BRIDGE CRANE MENU.

**Example 5: Using the PWM Function.**

Suppose that the motor of a machine tool is controlled by a drive. The tool must be lubricated based on the cutting speed. At max. cutting speed, the electrovalve controlling lubrication must work for 0.5 sec with a frequency of 1Hz (time period of 1 sec.): at max. speed, a duty cycle of 50% (Ton/T) is required, with a time period of 1 second; the time when the electrovalve opens is directly proportional to the cutting speed.

Spd1 is the max. cutting speed and dtc1 is the duty cycle required; the saw carrier frequency required for PWM must be 1 Hz (**P213**), the min. value must be 0rpm (when speed = 0rpm, the electrovalve is disabled) and max. value =  $Spd1 * 100 / dtc1 = 2 * Spd1$ .

Supposing that the tool can rotate in both directions, that Spd1 = 1500rpm and that the first digital output is used, parameters are set as follows:

**Table 53: MDO parameterization for the PWM function**

|              |   |                 |
|--------------|---|-----------------|
| <b>P270</b>  | MDO1: Digital output mode                                 | PWM MODE        |
| <b>P271</b>  | MDO1: Variable A selection                                | A72: Speed Ref. |
| <b>P272</b>  | MDO1: Variable B selection                                |                 |
| <b>P273</b>  | MDO1: Testing variable A                                  | >               |
| <b>P274</b>  | MDO1: Testing variable B                                  |                 |
| <b>P275</b>  | MDO1: Comparing value for Test A                          | 3000.00 rpm     |
| <b>P276</b>  | MDO1: Comparing value for Test B                          | 0.0 rpm         |
| <b>P277</b>  | MDO1: Function applied to the result of the two tests     |                 |
| <b>P277a</b> | MDO1: Variable C selection                                | D0: Disabled    |
| <b>P277b</b> | MDO1: Function applied to the result of f(A,B) and C test |                 |
| <b>P278</b>  | MDO1: Output logic level                                  | TRUE            |
| <b>P215</b>  | Saw signal frequency                                      | 1Hz             |

Parameter **P215** in the ANALOG AND FREQUENCY OUTPUTS MENU sets the frequency of the saw wave, i.e. the PWM frequency of the digital output.

In PWM mode, parameter **P275** sets the max. value (peak value) of the saw wave, while parameter **P276** sets the min. value of the saw wave.

The test selected with **P273** is performed between the analog variable selected in **P271** and the saw wave.

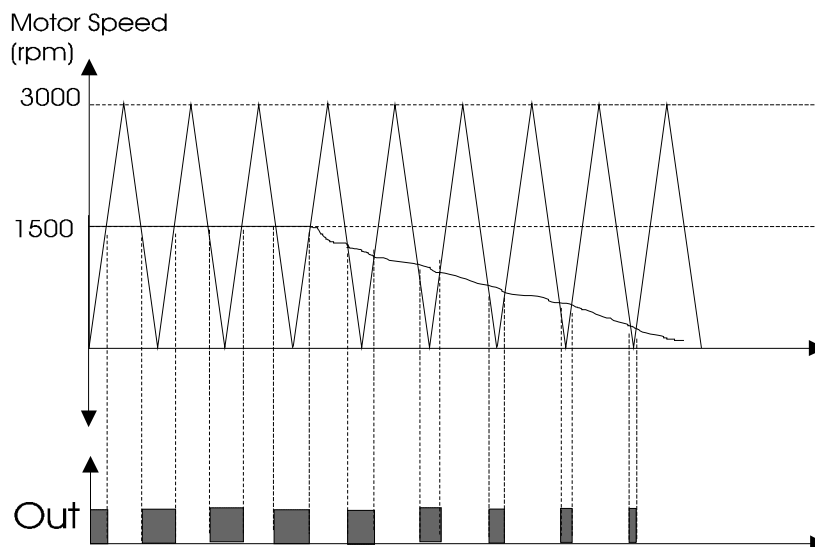

**Example 6: Digital output indicating the READY state to a PLC supervisor – using Inputs A, B, C**

This example shows how to activate a digital output based on the logic AND of 3 conditions A,B,C—particularly the ENABLE input, the condition of constant speed reference achieved, and the “Inverter Ok On” condition. An additional block applied to f(A,B) and C is used:

**Table 54: MDO parameterization for the Ready state of a PLC supervisor**

|              |   |                    |
|--------------|---|--------------------|
| <b>P270</b>  | MDO1: Digital output mode                                 | DOUBLE DIGITAL     |
| <b>P271</b>  | MDO1: Variable A selection                                | D21: Enable        |
| <b>P272</b>  | MDO1: Variable B selection                                | D40: Speed OK      |
| <b>P273</b>  | MDO1: Testing variable A                                  |                    |
| <b>P274</b>  | MDO1: Testing variable B                                  |                    |
| <b>P275</b>  | MDO1: Comparing value for Test A                          |                    |
| <b>P276</b>  | MDO1: Comparing value for Test B                          |                    |
| <b>P277</b>  | MDO1: Function applied to the result of the two tests     | (A) AND (B)        |
| <b>P277a</b> | MDO1: Variable C selection                                | D2: Inverter Ok On |
| <b>P277b</b> | MDO1: Function applied to the result of f(A,B) and C test | f(A,B) AND (C)     |
| <b>P278</b>  | MDO1: Output logic level                                  | TRUE               |

## 26.4. List of Parameters P270 to P305

Table 55: List of parameters P270 to P305

| Parameter | FUNCTION  | User Level | DEFAULT VALUES       | MODBUS Address |
|-----------|---|------------|----------------------|----------------|
| P270      | MDO1: Digital output mode                           | ADVANCED   | 3:ANALOG             | 870            |
| P271      | MDO1: Selecting variable A                          | ADVANCED   | A71: Speed           | 871            |
| P272      | MDO1: Selecting variable B                          | ADVANCED   | A71: Speed           | 872            |
| P273      | MDO1: Testing variable A                            | ADVANCED   | 0: >                 | 873            |
| P274      | MDO1: Testing variable B                            | ADVANCED   | 3: ≤                 | 874            |
| P275      | MDO1: Comparing value for Test A                    | ADVANCED   | 50 rpm               | 875            |
| P276      | MDO1: Comparing value for Test B                    | ADVANCED   | 10 rpm               | 876            |
| P277      | MDO1: Function applied to the result of the 2 tests | ADVANCED   | 1: (A) SET (B) RESET | 877            |
| P277a     | MDO1: Selecting variable C                          | ADVANCED   | 0: Disable           | 642            |
| P277b     | MDO1: Function applied to the result of f(A,B) C    | ADVANCED   | 0: f(A,B) OR C       | 643            |
| P278      | MDO1: Output logic level                            | ADVANCED   | 1: TRUE              | 878            |
| P279      | MDO2: Digital output mode                           | ADVANCED   | 6: BRAKE             | 879            |
| P280      | MDO2: Selecting variable A                          | ADVANCED   | A81: Trq Output      | 880            |
| P281      | MDO2: Selecting variable B                          | ADVANCED   | A71: Speed           | 881            |
| P282      | MDO2: Testing variable A                            | ADVANCED   | 0: >                 | 882            |
| P283      | MDO2: Testing variable B                            | ADVANCED   | 3: ≤                 | 883            |
| P284      | MDO2: Comparing value for Test A                    | ADVANCED   | 20%                  | 884            |
| P285      | MDO2: Comparing value for Test B                    | ADVANCED   | 50 rpm               | 885            |
| P286      | MDO2: Function applied to the result of the 2 tests | ADVANCED   | 1: (A) SET (B) RESET | 886            |
| P286a     | MDO2: Selecting variable C                          | ADVANCED   | 0: Disable           | 644            |
| P286b     | MDO2: Function applied to the result of f(A,B) C    | ADVANCED   | 0: f(A,B) OR C       | 645            |
| P287      | MDO2: Output logic level                            | ADVANCED   | 1: TRUE              | 887            |
| P288      | MDO3: Digital output mode                           | ADVANCED   | 1: DIGITAL           | 888            |
| P289      | MDO3: Selecting variable A                          | ADVANCED   | D3: Inverter Alarm   | 889            |
| P290      | MDO3: Selecting variable B                          | ADVANCED   | D3: Inverter Alarm   | 890            |
| P291      | MDO3: Testing variable A                            | ADVANCED   | 0: >                 | 891            |
| P292      | MDO3: Testing variable B                            | ADVANCED   | 0: >                 | 892            |
| P293      | MDO3: Comparing value for Test A                    | ADVANCED   | 0                    | 893            |
| P294      | MDO3: Comparing value for Test B                    | ADVANCED   | 0                    | 894            |
| P295      | MDO3: Function applied to the result of the 2 tests | ADVANCED   | 0: (A) OR (B)        | 895            |
| P295a     | MDO3: Selecting variable C                          | ADVANCED   | 0: Disable           | 646            |
| P295b     | MDO3: Function applied to the result of f(A,B) C    | ADVANCED   | 0: f(A,B) OR C       | 647            |
| P296      | MDO3: Output logic level                            | ADVANCED   | 0: FALSE             | 896            |
| P297      | MDO4: Digital output mode                           | ADVANCED   | 1: DIGITAL           | 897            |
| P298      | MDO4: Selecting variable A                          | ADVANCED   | D1: Inverter Run Ok  | 898            |
| P299      | MDO4: Selecting variable B                          | ADVANCED   | D1: Inverter Run Ok  | 899            |
| P300      | MDO4: Testing variable A                            | ADVANCED   | 0: >                 | 900            |
| P301      | MDO4: Testing variable B                            | ADVANCED   | 0: >                 | 901            |
| P302      | MDO4: Comparing value for Test A                    | ADVANCED   | 0                    | 902            |
| P303      | MDO4: Comparing value for Test B                    | ADVANCED   | 0                    | 903            |
| P304      | MDO4: Function applied to the result of the 2 tests | ADVANCED   | 0: (A) OR (B)        | 904            |
| P304a     | MDO4: Selecting variable C                          | ADVANCED   | 0: Disable           | 648            |
| P304b     | MDO4: Function applied to the result of f(A,B) C    | ADVANCED   | 0: f(A,B) OR C       | 649            |
| P305      | MDO4: Output logic level                            | ADVANCED   | 1: TRUE              | 905            |

**P270 MDO1: Digital Output Mode**

|             |                 |   |  |
|-------------|-----------------|---|--|
| <b>P270</b> | <b>Range</b>    | 0 ÷ 9   | 0: DISABLE<br>1: DIGITAL<br>2: DOUBLE DIGITAL<br>3: ANALOG<br>4: DOUBLE ANALOG<br>5: DOUBLE FULL<br>6: BRAKE<br>7: ABS BRAKE<br>8: ABS LIFT<br>9: PWM MODE |
|             | <b>Default</b>  | 3   | 3: ANALOG  |
|             | <b>Level</b>    | ADVANCED  |  |
|             | <b>Address</b>  | 870   |  |
|             | <b>Function</b> | This parameter defines the operating mode of <b>digital output 1</b> .<br>The different operating modes are described at the beginning of this chapter. |  |



**NOTE** MDO1 Digital output can be programmed only if the frequency output is not set up: **P200** = Disable (see ANALOG AND FREQUENCY OUTPUTS MENU).

**P271 MDO1: Selecting Variable A**

|             |                 |   |                |
|-------------|-----------------|---|----------------|
| <b>P271</b> | <b>Range</b>    | 0 ÷ 119   | See Table 47   |
|             | <b>Default</b>  | 61  | A71: Speed MEA |
|             | <b>Level</b>    | ADVANCED  |                |
|             | <b>Address</b>  | 871   |                |
|             | <b>Function</b> | This parameter selects the digital signal used to calculate the value of <b>MDO1</b> digital output.<br>It selects an analog variable used to calculate the value of <b>MDO1</b> digital output if one of the “analog” operating modes is selected.<br>Digital signals and analog variables are detailed in See Table 47. |                |

**P272 MDO1: Selecting Variable B**

|             |                 |   |                |
|-------------|-----------------|---|----------------|
| <b>P272</b> | <b>Range</b>    | 0 ÷ 119   | See Table 47   |
|             | <b>Default</b>  | 61  | A71: Speed MEA |
|             | <b>Level</b>    | ADVANCED  |                |
|             | <b>Address</b>  | 872   |                |
|             | <b>Function</b> | This parameter selects the second digital signal used to calculate the value of <b>MDO1</b> digital output.<br>It selects an analog variable used to calculate the value of <b>MDO1</b> digital input if one of the “analog” operating modes is selected.<br>Digital signals and analog variables are detailed in See Table 47. |                |

**P273 MDO1: Testing Variable A**

|             |                 |  |  |
|-------------|-----------------|--|--|
| <b>P273</b> | <b>Range</b>    | 0 ÷ 7  | 0: ><br>1: ≥<br>2: <<br>3: ≤<br>4: ABS(x) ><br>5: ABS(x) ≥<br>6: ABS(x) <<br>7: ABS(x) ≤ |
|             | <b>Default</b>  | 0  | 0: >   |
|             | <b>Level</b>    | ADVANCED   |  |
|             | <b>Address</b>  | 873  |  |
|             | <b>Function</b> | This parameter defines the test to be performed for the variable detected by <b>P271</b> using <b>P275</b> as a comparing value. |  |

**P274 MDO1: Testing Variable B**

|             |                 |  |  |
|-------------|-----------------|--|--|
| <b>P274</b> | <b>Range</b>    | 0 ÷ 7  | 0: ><br>1: ≥<br>2: <<br>3: ≤<br>4: ABS(x) ><br>5: ABS(x) ≥<br>6: ABS(x) <<br>7: ABS(x) ≤ |
|             | <b>Default</b>  | 3  | 3: ≤   |
|             | <b>Level</b>    | ADVANCED   |  |
|             | <b>Address</b>  | 874  |  |
|             | <b>Function</b> | This parameter defines the test to be performed for the variable detected by <b>P272</b> using <b>P276</b> as a comparing value. |  |

**P275 MDO1: Comparing Value for Test A**

|             |                 |   |   |
|-------------|-----------------|---|---|
| <b>P275</b> | <b>Range</b>    | -32000 ÷ 32000  | -320.00 % ÷ 320.00 %<br><i>% of the full-scale value of selected variable A, see Table 47</i> |
|             | <b>Default</b>  | 50  | 50 rpm  |
|             | <b>Level</b>    | ADVANCED  |   |
|             | <b>Address</b>  | 875   |   |
|             | <b>Function</b> | This parameter defines the comparing value with the selected variable for test A. |   |

**P276 MDO1: Comparing Value for Test B**

|             |                 |   |   |
|-------------|-----------------|---|---|
| <b>P276</b> | <b>Range</b>    | -32000 ÷ 32000  | -320.00 % ÷ 320.00 %<br><i>% of the full-scale value of selected variable B, see Table 47</i> |
|             | <b>Default</b>  | 10  | 10 rpm  |
|             | <b>Level</b>    | ADVANCED  |   |
|             | <b>Address</b>  | 876   |   |
|             | <b>Function</b> | This parameter defines the comparing value with the selected variable for test B. |   |

**P277 MDO1: Function Applied to the Result of the 2 Tests**

|             |                 |  |   |
|-------------|-----------------|--|---|
| <b>P277</b> | <b>Range</b>    | 0 ÷ 12   | 0: (A) OR (B)<br>1: (A) SET (B) RESET<br>2: (A) AND (B)<br>3: (A) XOR (B)<br>4: (A) NOR (B)<br>5: (A) NAND (B)<br>6: (A\ OR (B)<br>7: (A) OR (B\<br>8: (A\ AND (B)<br>9: (A) AND (B\<br>10: (A) RESET (B) SET RISING EDGE<br>11: (A) SET (B) RESET FALLING EDGE<br>12: (A) RESET (B) SET FALLING EDGE |
|             | <b>Default</b>  | 1  | 1: (A) SET (B) RESET  |
|             | <b>Level</b>    | ADVANCED   |   |
|             | <b>Address</b>  | 877  |   |
|             | <b>Function</b> | This parameter determines the logic function applied to the result of the two tests allowing calculating the output value. |   |

**P277a MDO1: Selecting Variable C**

|             |                 |   |              |
|-------------|-----------------|---|--------------|
| <b>277a</b> | <b>Range</b>    | 0 ÷ 59  | See Table 47 |
|             | <b>Default</b>  | 0   | D0: Disable  |
|             | <b>Level</b>    | ADVANCED  |              |
|             | <b>Address</b>  | 642   |              |
|             | <b>Function</b> | This parameter selects the digital signal used to calculate the value of <b>MDO1</b> digital output.<br>The digital signals that can be selected are given in Table 47. |              |

**P277b MDO1: Function Applied to the Result of f(A,B) C**

|              |                 |  |  |
|--------------|-----------------|--|--|
| <b>P277b</b> | <b>Range</b>    | 0 ÷ 12   | 0: f(A,B) OR (C)<br>1: f(A,B) SET (C) RESET RISING EDGE<br>2: f(A,B) AND (C)<br>3: f(A,B) XOR (C)<br>4: f(A,B) NOR (C)<br>5: f(A,B) NAND (C)<br>6: f(A,B)\ OR (C)<br>7: f(A,B) OR (C\<br>8: f(A,B)\ AND (C)<br>9: f(A,B) AND (C\<br>10: f(A,B) RESET (C) SET RISING EDGE<br>11: f(A,B) SET (C) RESET FALLING EDGE<br>12: f(A,B) RESET (C) SET FALLING EDGE |
|              | <b>Default</b>  | 0  | 0: f(A,B) OR (C)   |
|              | <b>Level</b>    | ADVANCED   |  |
|              | <b>Address</b>  | 643  |  |
|              | <b>Function</b> | This parameter determines the logic function applied to the result of the two tests allowing calculating the output value. |  |

**P278 MDO1: Output Logic Level**

|             |                 |  |                     |
|-------------|-----------------|--|---------------------|
| <b>P278</b> | <b>Range</b>    | 0–1  | 0: FALSE<br>1: TRUE |
|             | <b>Default</b>  | 1  | 1: TRUE             |
|             | <b>Level</b>    | ADVANCED   |                     |
|             | <b>Address</b>  | 878  |                     |
|             | <b>Function</b> | MDO1 digital output logic function to apply a logic reversal (negation) to the calculated output signal: (0) FALSE = a logic negation is applied; (1) TRUE = no negation is applied. |                     |

**P279 MDO2: Digital Output Mode**

|             |                 |  |  |
|-------------|-----------------|--|--|
| <b>P279</b> | <b>Range</b>    | 0 ÷ 9  | 0: DISABLE<br>1: DIGITAL<br>2: DOUBLE DIGITAL<br>3: ANALOG<br>4: DOUBLE ANALOG<br>5: DOUBLE FULL<br>6: BRAKE<br>7: ABS BRAKE<br>8: ABS LIFT<br>9: PWM MODE |
|             | <b>Default</b>  | 6  | 1: BRAKE   |
|             | <b>Level</b>    | ADVANCED   |  |
|             | <b>Address</b>  | 879  |  |
|             | <b>Function</b> | This parameter defines the operating mode of <b>digital output 2</b> . The different operating modes are described at the beginning of this chapter. |  |

**P280 MDO2: Selecting Variable A**

|             |                 |  |                    |
|-------------|-----------------|--|--------------------|
| <b>P280</b> | <b>Range</b>    | 0 ÷ 119  | See Table 47       |
|             | <b>Default</b>  | 71   | A81: Torque Output |
|             | <b>Level</b>    | ADVANCED   |                    |
|             | <b>Address</b>  | 880  |                    |
|             | <b>Function</b> | This parameter selects the digital signal used to calculate the value of <b>MDO2</b> digital output.<br>It selects an analog variable used to calculate the value of <b>MDO2</b> digital input if one of the “analog” operating modes is selected.<br>Digital signals and analog variables are detailed in Table 47. |                    |

**P281 MDO2: Selecting Variable B**

|             |                 |   |                |
|-------------|-----------------|---|----------------|
| <b>P281</b> | <b>Range</b>    | 0 ÷ 119   | See Table 47   |
|             | <b>Default</b>  | 61  | A71: Speed MEA |
|             | <b>Level</b>    | ADVANCED  |                |
|             | <b>Address</b>  | 881   |                |
|             | <b>Function</b> | This parameter selects the second digital signal used to calculate the value of <b>MDO2</b> digital output.<br>It selects an analog variable used to calculate the value of <b>MDO2</b> digital input if one of the “analog” operating modes is selected.<br>Digital signals and analog variables are detailed in Table 47. |                |

**P282 MDO2: Testing Variable A**

|             |                 |  |  |
|-------------|-----------------|--|--|
| <b>P282</b> | <b>Range</b>    | 0 ÷ 7  | 0: ><br>1: ≥<br>2: <<br>3: ≤<br>4: ABS(x) ><br>5: ABS(x) ≥<br>6: ABS(x) <<br>7: ABS(x) ≤ |
|             | <b>Default</b>  | 0  | 0: >   |
|             | <b>Level</b>    | ADVANCED   |  |
|             | <b>Address</b>  | 882  |  |
|             | <b>Function</b> | This parameter defines the test to be performed for the variable detected by <b>P280</b> using <b>P284</b> as a comparing value. |  |

**P283 MDO2: Testing Variable B**

|             |                 |  |  |
|-------------|-----------------|--|--|
| <b>P283</b> | <b>Range</b>    | 0 ÷ 7  | 0: ><br>1: ≥<br>2: <<br>3: ≤<br>4: ABS(x) ><br>5: ABS(x) ≥<br>6: ABS(x) <<br>7: ABS(x) ≤ |
|             | <b>Default</b>  | 0  | 3: ≤   |
|             | <b>Level</b>    | ADVANCED   |  |
|             | <b>Address</b>  | 883  |  |
|             | <b>Function</b> | This parameter defines the test to be performed for the variable detected by <b>P281</b> using <b>P285</b> as a comparing value. |  |

**P284 MDO2: Comparing Value for Test A**

|             |                 |   |   |
|-------------|-----------------|---|---|
| <b>P284</b> | <b>Range</b>    | -32000 ÷ 32000  | -320.00 % ÷ 320.00 %<br><i>% of the full-scale value of selected variable A, see Table 47</i> |
|             | <b>Default</b>  | 2000  | 20%   |
|             | <b>Level</b>    | ADVANCED  |   |
|             | <b>Address</b>  | 884   |   |
|             | <b>Function</b> | This parameter defines the comparing value with the selected variable for test A. |   |

**P285 MDO2: Comparing Value for Test B**

|             |                 |   |   |
|-------------|-----------------|---|---|
| <b>P285</b> | <b>Range</b>    | -32000 ÷ 32000  | -320.00 % ÷ 320.00 %<br><i>% of the full-scale value of selected variable B, see Table 47</i> |
|             | <b>Default</b>  | 50  | 50 rpm  |
|             | <b>Level</b>    | ADVANCED  |   |
|             | <b>Address</b>  | 885   |   |
|             | <b>Function</b> | This parameter defines the comparing value with the selected variable for test B. |   |

**P286 MDO2: Function Applied to the Result of the 2 Tests**

|             |                 |  |   |
|-------------|-----------------|--|---|
| <b>P286</b> | <b>Range</b>    | 0 ÷ 12   | 0: (A) OR (B)<br>1: (A) SET (B) RESET<br>2: (A) AND (B)<br>3: (A) XOR (B)<br>4: (A) NOR (B)<br>5: (A) NAND (B)<br>6: (A\ OR (B)<br>7: (A) OR (B\<br>8: (A\ AND (B)<br>9: (A) AND (B\<br>10: (A) RESET (B) SET RISING EDGE<br>11: (A) SET (B) RESET FALLING EDGE<br>12: (A) RESET (B) SET FALLING EDGE |
|             | <b>Default</b>  | 1  | 1: (A) SET (B) RESET  |
|             | <b>Level</b>    | ADVANCED   |   |
|             | <b>Address</b>  | 886  |   |
|             | <b>Function</b> | This parameter determines the logic function applied to the result of the two tests allowing calculating the output value. |   |

**P286a MDO2: Selecting Variable C**

|              |                 |   |              |
|--------------|-----------------|---|--------------|
| <b>P286a</b> | <b>Range</b>    | 0 ÷ 59  | See Table 47 |
|              | <b>Default</b>  | 0   | D0: Disable  |
|              | <b>Level</b>    | ADVANCED  |              |
|              | <b>Address</b>  | 644   |              |
|              | <b>Function</b> | This parameter selects the digital signal used to calculate the value of <b>MDO2</b> digital output.<br>The digital signals that can be selected are given in Table 47. |              |

**P286b MDO2: Function Applied to the Result of f(A,B) C**

|              |                 |  |  |
|--------------|-----------------|--|--|
| <b>P286b</b> | <b>Range</b>    | 0 ÷ 12   | 0: f(A,B) OR (C)<br>1: f(A,B) SET (C) RESET RISING EDGE<br>2: f(A,B) AND (C)<br>3: f(A,B) XOR (C)<br>4: f(A,B) NOR (C)<br>5: f(A,B) NAND (C)<br>6: f(A,B)\ OR (C)<br>7: f(A,B) OR (C\<br>8: f(A,B)\ AND (C)<br>9: f(A,B) AND (C\<br>10: f(A,B) RESET (C) SET RISING EDGE<br>11: f(A,B) SET (C) RESET FALLING EDGE<br>12: f(A,B) RESET (C) SET FALLING EDGE |
|              | <b>Default</b>  | 1  | 1: (A) SET (B) RESET   |
|              | <b>Level</b>    | ADVANCED   |  |
|              | <b>Address</b>  | 645  |  |
|              | <b>Function</b> | This parameter determines the logic function applied to the result of the two tests allowing calculating the output value. |  |

**P287 MDO2: Output Logic Level**

|             |                 |  |                     |
|-------------|-----------------|--|---------------------|
| <b>P287</b> | <b>Range</b>    | 0–1  | 0: FALSE<br>1: TRUE |
|             | <b>Default</b>  | 1  | 1: TRUE             |
|             | <b>Level</b>    | ADVANCED   |                     |
|             | <b>Address</b>  | 887  |                     |
|             | <b>Function</b> | MDO2 digital output logic function to apply a logic reversal (negation) to the calculated output signal: (0) FALSE = a logic negation is applied; (1) TRUE = no negation is applied. |                     |

**P288 MDO3: Digital Output Mode**

|             |                 |  |   |
|-------------|-----------------|--|---|
| <b>P288</b> | <b>Range</b>    | 0 ÷ 8  | 0: DISABLE<br>1: DIGITAL<br>2: DOUBLE DIGITAL<br>3: ANALOG<br>4: DOUBLE ANALOG<br>5: DOUBLE FULL<br>6: BRAKE<br>7: ABS BRAKE<br>8: ABS LIFT |
|             | <b>Default</b>  | 1  | 1: DIGITAL  |
|             | <b>Level</b>    | ADVANCED   |   |
|             | <b>Address</b>  | 888  |   |
|             | <b>Function</b> | This parameter defines the operating mode of <b>digital output 3</b> . The different operating modes are described at the beginning of this chapter. |   |

**P289 MDO3: Selecting Variable A**

|             |                 |   |                    |
|-------------|-----------------|---|--------------------|
| <b>P289</b> | <b>Range</b>    | 0 ÷ 119   | See Table 47       |
|             | <b>Default</b>  | 3   | D3: Inverter Alarm |
|             | <b>Level</b>    | ADVANCED  |                    |
|             | <b>Address</b>  | 889   |                    |
|             | <b>Function</b> | This parameter selects the digital signal used to calculate the value of <b>MDO3</b> digital output.<br>It selects an analog variable used to calculate the value of <b>MDO3</b> digital input if one of the “analog” operating modes is selected.<br>Digital signals and analog variables are detailed in Table 47 |                    |

**P290 MDO3: Selecting Variable B**

|             |                 |   |                    |
|-------------|-----------------|---|--------------------|
| <b>P290</b> | <b>Range</b>    | 0 ÷ 119   | See Table 47       |
|             | <b>Default</b>  | 3   | D3: Inverter Alarm |
|             | <b>Level</b>    | ADVANCED  |                    |
|             | <b>Address</b>  | 890   |                    |
|             | <b>Function</b> | This parameter selects the second digital signal used to calculate the value of <b>MDO3</b> digital output.<br>It selects an analog variable used to calculate the value of digital input <b>MDO3</b> if one of the “analog” operating modes is selected.<br>Digital signals and analog variables detailed in Table 47. |                    |

**P291 MDO3: Testing Variable A**

|             |                 |  |  |
|-------------|-----------------|--|--|
| <b>P291</b> | <b>Range</b>    | 0 ÷ 7  | 0: ><br>1: ≥<br>2: <<br>3: ≤<br>4: ABS(x) ><br>5: ABS(x) ≥<br>6: ABS(x) <<br>7: ABS(x) ≤ |
|             | <b>Default</b>  | 0  | 0: >   |
|             | <b>Level</b>    | ADVANCED   |  |
|             | <b>Address</b>  | 891  |  |
|             | <b>Function</b> | This parameter defines the test to be performed for the variable detected by <b>P289</b> using <b>P293</b> as a comparing value. |  |

**P292 MDO3: Testing Variable B**

|             |                 |  |  |
|-------------|-----------------|--|--|
| <b>P292</b> | <b>Range</b>    | 0 ÷ 7  | 0: ><br>1: ≥<br>2: <<br>3: ≤<br>4: ABS(x) ><br>5: ABS(x) ≥<br>6: ABS(x) <<br>7: ABS(x) ≤ |
|             | <b>Default</b>  | 0  | 0: >   |
|             | <b>Level</b>    | ADVANCED   |  |
|             | <b>Address</b>  | 892  |  |
|             | <b>Function</b> | This parameter defines the test to be performed for the variable detected by <b>P290</b> using <b>P294</b> as a comparing value. |  |

**P293 MDO3: Comparing Value for Test A**

|             |                 |   |  |
|-------------|-----------------|---|--|
| <b>P293</b> | <b>Range</b>    | -32000 ÷ 32000  | -320.00 % ÷ 320.00 %<br>% of the full-scale value of selected variable A, see Table 47 |
|             | <b>Default</b>  | 0   | 0  |
|             | <b>Level</b>    | ADVANCED  |  |
|             | <b>Address</b>  | 893   |  |
|             | <b>Function</b> | This parameter defines the comparing value with the variable selected for test A. |  |

**P294 MDO3: Comparing Value for Test B**

|             |                 |   |  |
|-------------|-----------------|---|--|
| <b>P294</b> | <b>Range</b>    | -32000 ÷ 32000  | -320.00 % ÷ 320.00 %<br>% of the full-scale value of selected variable B, see Table 47 |
|             | <b>Default</b>  | 0   | 0  |
|             | <b>Level</b>    | ADVANCED  |  |
|             | <b>Address</b>  | 894   |  |
|             | <b>Function</b> | This parameter defines the comparing value with the variable selected for test B. |  |

**P295 MDO3: Function Applied to the Result of the 2 Tests**

|             |                 |  |   |
|-------------|-----------------|--|---|
| <b>P295</b> | <b>Range</b>    | 0 ÷ 12   | 0: (A) OR (B)<br>1: (A) SET (B) RESET<br>2: (A) AND (B)<br>3: (A) XOR (B)<br>4: (A) NOR (B)<br>5: (A) NAND (B)<br>6: (A\ OR (B)<br>7: (A) OR (B\<br>8: (A\ AND (B)<br>9: (A) AND (B\<br>10: (A) RESET (B) SET RISING EDGE<br>11: (A) SET (B) RESET FALLING EDGE<br>12: (A) RESET (B) SET FALLING EDGE |
|             | <b>Default</b>  | 0  | 0: (A) OR (B)   |
|             | <b>Level</b>    | ADVANCED   |   |
|             | <b>Address</b>  | 895  |   |
|             | <b>Function</b> | This parameter determines the logic function applied to the result of the two tests allowing calculating the output value. |   |

**P295a MDO3: Selecting Variable C**

|              |                 |   |              |
|--------------|-----------------|---|--------------|
| <b>P295a</b> | <b>Range</b>    | 0 ÷ 59  | See Table 47 |
|              | <b>Default</b>  | 0   | D0: Disable  |
|              | <b>Level</b>    | ADVANCED  |              |
|              | <b>Address</b>  | 646   |              |
|              | <b>Function</b> | This parameter selects the digital signal used to calculate the value of <b>MDO3</b> digital output.<br>The digital signals that can be selected are given in Table 47. |              |

**P295b MDO3: Function Applied to the Result of f(A,B) C**

|              |                 |  |  |
|--------------|-----------------|--|--|
| <b>P295b</b> | <b>Range</b>    | 0 ÷ 12   | 0: f(A,B) OR (C)<br>1: f(A,B) SET (C) RESET RISING EDGE<br>2: f(A,B) AND (C)<br>3: f(A,B) XOR (C)<br>4: f(A,B) NOR (C)<br>5: f(A,B) NAND (C)<br>6: f(A,B)\ OR (C)<br>7: f(A,B) OR (C\<br>8: f(A,B)\ AND (C)<br>9: f(A,B) AND (C\<br>10: f(A,B) RESET (C) SET RISING EDGE<br>11: f(A,B) SET (C) RESET FALLING EDGE<br>12: f(A,B) RESET (C) SET FALLING EDGE |
|              | <b>Default</b>  | 1  | 1: (A) SET (B) RESET   |
|              | <b>Level</b>    | ADVANCED   |  |
|              | <b>Address</b>  | 647  |  |
|              | <b>Function</b> | This parameter determines the logic function applied to the result of the two tests allowing calculating the output value. |  |

**P296 MDO3: Output Logic Level**

|             |                 |  |                     |
|-------------|-----------------|--|---------------------|
| <b>P296</b> | <b>Range</b>    | 0–1  | 0: FALSE<br>1: TRUE |
|             | <b>Default</b>  | 0  | 0: FALSE            |
|             | <b>Level</b>    | ADVANCED   |                     |
|             | <b>Address</b>  | 896  |                     |
|             | <b>Function</b> | MDO3 digital output logic function to apply a logic reversal (negation) to the calculated output signal: (0) FALSE = a logic negation is applied; (1) TRUE = no negation is applied. |                     |

**P297 MDO4: Digital Output Mode**

|             |                 |  |   |
|-------------|-----------------|--|---|
| <b>P297</b> | <b>Range</b>    | 0 ÷ 8  | 0: DISABLE<br>1: DIGITAL<br>2: DOUBLE DIGITAL<br>3: ANALOG<br>4: DOUBLE ANALOG<br>5: DOUBLE FULL<br>6: BRAKE<br>7: ABS BRAKE<br>8: ABS LIFT |
|             | <b>Default</b>  | 1  | 1: DIGITAL  |
|             | <b>Level</b>    | ADVANCED   |   |
|             | <b>Address</b>  | 897  |   |
|             | <b>Function</b> | This parameter defines the operating mode of <b>digital output 4</b> . The different operating modes are described at the beginning of this chapter. |   |

**P298 MDO4: Selecting Variable A**

|             |                 |  |                     |
|-------------|-----------------|--|---------------------|
| <b>P298</b> | <b>Range</b>    | 0 ÷ 119  | See Table 47        |
|             | <b>Default</b>  | 1  | D1: Inverter Run Ok |
|             | <b>Level</b>    | ADVANCED   |                     |
|             | <b>Address</b>  | 898  |                     |
|             | <b>Function</b> | This parameter selects the digital signal used to calculate the value of <b>MDO4</b> digital output.<br>It selects an analog variable used to calculate the value of <b>MDO4</b> digital input if one of the “analog” operating modes is selected.<br>Digital signals and analog variables are detailed in Table 47. |                     |

**P299 MDO4: Selecting Variable B**

|             |                 |   |                     |
|-------------|-----------------|---|---------------------|
| <b>P299</b> | <b>Range</b>    | 0 ÷ 119   | See Table 47        |
|             | <b>Default</b>  | 1   | D1: Inverter Run Ok |
|             | <b>Level</b>    | ADVANCED  |                     |
|             | <b>Address</b>  | 899   |                     |
|             | <b>Function</b> | This parameter selects the second digital signal used to calculate the value of <b>MDO4</b> digital output.<br>It selects an analog variable used to calculate the value of <b>MDO4</b> digital input if one of the “analog” operating modes is selected.<br>Digital signals and analog variables are detailed in Table 47. |                     |

**P300 MDO4: Testing Variable A**

|             |                 |  |  |
|-------------|-----------------|--|--|
| <b>P300</b> | <b>Range</b>    | 0 ÷ 7  | 0: ><br>1: ≥<br>2: <<br>3: ≤<br>4: ABS(x) ><br>5: ABS(x) ≥<br>6: ABS(x) <<br>7: ABS(x) ≤ |
|             | <b>Default</b>  | 0  | 0: >   |
|             | <b>Level</b>    | ADVANCED   |  |
|             | <b>Address</b>  | 900  |  |
|             | <b>Function</b> | This parameter defines the test to be performed for the variable detected by <b>P298</b> using <b>P302</b> as a comparing value. |  |

**P301 MDO4: Testing Variable B**

|             |                 |  |  |
|-------------|-----------------|--|--|
| <b>P301</b> | <b>Range</b>    | 0 ÷ 7  | 0: ><br>1: ≥<br>2: <<br>3: ≤<br>4: ABS(x) ><br>5: ABS(x) ≥<br>6: ABS(x) <<br>7: ABS(x) ≤ |
|             | <b>Default</b>  | 0  | 0: >   |
|             | <b>Level</b>    | ADVANCED   |  |
|             | <b>Address</b>  | 901  |  |
|             | <b>Function</b> | This parameter defines the test to be performed for the variable detected by <b>P299</b> using <b>P303</b> as a comparing value. |  |

**P302 MDO4: Comparing Value for Test A**

|             |                 |   |   |
|-------------|-----------------|---|---|
| <b>P302</b> | <b>Range</b>    | -32000 ÷ 32000  | -320.00 % ÷ 320.00 %<br><i>% of the full-scale value of selected variable A, see Table 47</i> |
|             | <b>Default</b>  | 0   | 0   |
|             | <b>Level</b>    | ADVANCED  |   |
|             | <b>Address</b>  | 902   |   |
|             | <b>Function</b> | This parameter defines the comparing value with the selected variable for test A. |   |

**P303 MDO4: Comparing Value for Test B**

|             |                 |   |   |
|-------------|-----------------|---|---|
| <b>P303</b> | <b>Range</b>    | -32000 ÷ 32000  | -320.00 % ÷ 320.00 %<br><i>% of the full-scale value of selected variable B, see Table 47</i> |
|             | <b>Default</b>  | 0   | 0   |
|             | <b>Level</b>    | ADVANCED  |   |
|             | <b>Address</b>  | 903   |   |
|             | <b>Function</b> | This parameter defines the comparing value with the selected variable for test B. |   |

**P304 MDO4: Function Applied to the Result of the 2 Tests**

|             |                 |  |   |
|-------------|-----------------|--|---|
| <b>P304</b> | <b>Range</b>    | 0 ÷ 12   | 0: (A) OR (B)<br>1: (A) SET (B) RESET<br>2: (A) AND (B)<br>3: (A) XOR (B)<br>4: (A) NOR (B)<br>5: (A) NAND (B)<br>6: (A) OR (B)<br>7: (A) OR (B)<br>8: (A) AND (B)<br>9: (A) AND (B)<br>10: (A) RESET (B) SET RISING EDGE<br>11: (A) SET (B) RESET FALLING EDGE<br>12: (A) RESET (B) SET FALLING EDGE |
|             | <b>Default</b>  | 0  | 0: (A) OR (B)   |
|             | <b>Level</b>    | ADVANCED   |   |
|             | <b>Address</b>  | 904  |   |
|             | <b>Function</b> | This parameter determines the logic function applied to the result of the two tests allowing calculating the output value. |   |

**P304a MDO4: Selecting Variable C**

|              |                 |   |              |
|--------------|-----------------|---|--------------|
| <b>P304a</b> | <b>Range</b>    | 0 ÷ 59  | See Table 47 |
|              | <b>Default</b>  | 0   | D0: Disable  |
|              | <b>Level</b>    | ADVANCED  |              |
|              | <b>Address</b>  | 648   |              |
|              | <b>Function</b> | This parameter selects the digital signal used to calculate the value of <b>MDO4</b> digital output.<br>The digital signals that can be selected are given in Table 47. |              |

**P304b MDO4: Function Applied to the Result of f(A,B) C**

|              |                 |  |  |
|--------------|-----------------|--|--|
| <b>P304b</b> | <b>Range</b>    | 0 ÷ 12   | 0: f(A,B) OR (C)<br>1: f(A,B) SET (C) RESET RISING EDGE<br>2: f(A,B) AND (C)<br>3: f(A,B) XOR (C)<br>4: f(A,B) NOR (C)<br>5: f(A,B) NAND (C)<br>6: f(A,B)\ OR (C)<br>7: f(A,B) OR (C)<br>8: f(A,B)\ AND (C)<br>9: f(A,B) AND (C)<br>10: f(A,B) RESET (C) SET RISING EDGE<br>11: f(A,B) SET (C) RESET FALLING EDGE<br>12: f(A,B) RESET (C) SET FALLING EDGE |
|              | <b>Default</b>  | 1  | 1: (A) SET (B) RESET   |
|              | <b>Level</b>    | ADVANCED   |  |
|              | <b>Address</b>  | 649  |  |
|              | <b>Function</b> | This parameter determines the logic function applied to the result of the two tests allowing calculating the output value. |  |

**P305 MDO4: Output Logic Level**

|             |                 |   |                     |
|-------------|-----------------|---|---------------------|
| <b>P305</b> | <b>Range</b>    | 0–1   | 0: FALSE<br>1: TRUE |
|             | <b>Default</b>  | 1   | 1: TRUE             |
|             | <b>Level</b>    | ADVANCED  |                     |
|             | <b>Address</b>  | 905   |                     |
|             | <b>Function</b> | <b>MDO4</b> digital output logic function to apply a logic reversal (negation) to the calculated output signal: (0) FALSE = a logic negation is applied; (1) TRUE = no negation is applied. |                     |

## 27. AUXILIARY DIGITAL OUTPUTS MENU

### 27.1. Overview

This menu includes the parameters allowing allocating the control functions implemented via the digital inputs located on I/O expansion boards. This menu can be viewed only after enabling data acquisition from the expansion boards.

### 27.2. List of Parameters P306 to P317

Table 56: List of parameters P306 to P317

| Parameter | FUNCTION                  | User Level  | DEFAULT VALUES | MODBUS Address |
|-----------|---------------------------|-------------|----------------|----------------|
| P306      | XMDO1: Signal selection   | ENGINEERING | D0: Disable    | 906            |
| P307      | XMDO1: Output logic level | ENGINEERING | 1: True        | 907            |
| P308      | XMDO2: Signal selection   | ENGINEERING | D0: Disable    | 908            |
| P309      | XMDO2: Output logic level | ENGINEERING | 1: True        | 909            |
| P310      | XMDO3: Signal selection   | ENGINEERING | D0: Disable    | 910            |
| P311      | XMDO3: Output logic level | ENGINEERING | 1: True        | 911            |
| P312      | XMDO4: Signal selection   | ENGINEERING | D0: Disable    | 912            |
| P313      | XMDO4: Output logic level | ENGINEERING | 1: True        | 913            |
| P314      | XMDO5: Signal selection   | ENGINEERING | D0: Disable    | 914            |
| P315      | XMDO5: Output logic level | ENGINEERING | 1: True        | 915            |
| P316      | XMDO6: Signal selection   | ENGINEERING | D0: Disable    | 916            |
| P317      | XMDO6: Output logic level | ENGINEERING | 1: True        | 917            |

#### P306 XMDO1: Signal Selection

|             |                 |   |              |
|-------------|-----------------|---|--------------|
| <b>P306</b> | <b>Range</b>    | 0 ÷ 59  | See Table 47 |
|             | <b>Default</b>  | 0   | D0: Disable  |
|             | <b>Level</b>    | ENGINEERING   |              |
|             | <b>Address</b>  | 906   |              |
|             | <b>Function</b> | Selects the digital signal used to calculate the value of <b>XMDO1</b> digital output. It selects an analog variable used to calculate the value of <b>XMDO1</b> digital input if one of the “analog” operating modes is selected. Digital signals and analog variables are detailed in Table 47. |              |

#### P307 XMDO1: Output Logic Level

|             |                 |  |                     |
|-------------|-----------------|--|---------------------|
| <b>P307</b> | <b>Range</b>    | 0–1  | 0: FALSE<br>1: TRUE |
|             | <b>Default</b>  | 1  | 1: TRUE             |
|             | <b>Level</b>    | ENGINEERING  |                     |
|             | <b>Address</b>  | 907  |                     |
|             | <b>Function</b> | <b>XMDO1</b> digital output logic function to apply a logic reversal (negation) to the calculated output signal: (0) FALSE = a logic negation is applied; (1) TRUE = no negation is applied. |                     |

**P308 XMDO2: Signal Selection**

|             |                 |   |              |
|-------------|-----------------|---|--------------|
| <b>P308</b> | <b>Range</b>    | 0 ÷ 59  | See Table 47 |
|             | <b>Default</b>  | 0   | D0: Disable  |
|             | <b>Level</b>    | ENGINEERING   |              |
|             | <b>Address</b>  | 908   |              |
|             | <b>Function</b> | Selects the digital signal used to calculate the value of <b>XMDO2</b> digital output. It selects an analog variable used to calculate the value of <b>XMDO2</b> digital input if one of the “analog” operating modes is selected. Digital signals and analog variables are detailed in Table 47. |              |

**P309 XMDO2: Output Logic Level**

|             |                 |  |                     |
|-------------|-----------------|--|---------------------|
| <b>P309</b> | <b>Range</b>    | 0–1  | 0: FALSE<br>1: TRUE |
|             | <b>Default</b>  | 1  | 1: TRUE             |
|             | <b>Level</b>    | ENGINEERING  |                     |
|             | <b>Address</b>  | 909  |                     |
|             | <b>Function</b> | <b>XMDO2</b> digital output logic function to apply a logic reversal (negation) to the calculated output signal: (0) FALSE = a logic negation is applied; (1) TRUE = no negation is applied. |                     |

**P310 XMDO3: Signal Selection**

|             |                 |   |              |
|-------------|-----------------|---|--------------|
| <b>P310</b> | <b>Range</b>    | 0 ÷ 59  | See Table 47 |
|             | <b>Default</b>  | 0   | D0: Disable  |
|             | <b>Level</b>    | ENGINEERING   |              |
|             | <b>Address</b>  | 910   |              |
|             | <b>Function</b> | Selects the digital signal used to calculate the value of <b>XMDO3</b> digital output. It selects an analog variable used to calculate the value of <b>XMDO3</b> digital input if one of the “analog” operating modes is selected. Digital signals and analog variables are detailed in Table 47. |              |

**P311 XMDO3: Output Logic Level**

|             |                 |  |                     |
|-------------|-----------------|--|---------------------|
| <b>P311</b> | <b>Range</b>    | 0–1  | 0: FALSE<br>1: TRUE |
|             | <b>Default</b>  | 1  | 1: TRUE             |
|             | <b>Level</b>    | ENGINEERING  |                     |
|             | <b>Address</b>  | 911  |                     |
|             | <b>Function</b> | <b>XMDO3</b> digital output logic function to apply a logic reversal (negation) to the calculated output signal: (0) FALSE = a logic negation is applied; (1) TRUE = no negation is applied. |                     |

**P312 XMDO4: Signal Selection**

|             |                 |   |              |
|-------------|-----------------|---|--------------|
| <b>P312</b> | <b>Range</b>    | 0 ÷ 59  | See Table 47 |
|             | <b>Default</b>  | 0   | D0: Disable  |
|             | <b>Level</b>    | ENGINEERING   |              |
|             | <b>Address</b>  | 912   |              |
|             | <b>Function</b> | Selects the digital signal used to calculate the value of <b>XMDO4</b> digital output. It selects an analog variable used to calculate the value of <b>XMDO4</b> digital input if one of the “analog” operating modes is selected. Digital signals and analog variables are detailed in Table 47. |              |

**P313 XMDO4: Output Logic Level**

|             |                 |  |                     |
|-------------|-----------------|--|---------------------|
| <b>P313</b> | <b>Range</b>    | 0–1  | 0: TRUE<br>1: FALSE |
|             | <b>Default</b>  | 1  | 1: FALSE            |
|             | <b>Level</b>    | ENGINEERING  |                     |
|             | <b>Address</b>  | 913  |                     |
|             | <b>Function</b> | <b>XMDO4</b> digital output logic function to apply a logic reversal (negation) to the calculated output signal: (0) FALSE = a logic negation is applied; (1) TRUE = no negation is applied. |                     |

**P314 XMDO5: Signal Selection**

|             |                 |   |              |
|-------------|-----------------|---|--------------|
| <b>P314</b> | <b>Range</b>    | 0 ÷ 59  | See Table 47 |
|             | <b>Default</b>  | 0   | D0: Disable  |
|             | <b>Level</b>    | ENGINEERING   |              |
|             | <b>Address</b>  | 914   |              |
|             | <b>Function</b> | Selects the digital signal used to calculate the value of <b>XMDO5</b> digital output. It selects an analog variable used to calculate the value of <b>XMDO5</b> digital input if one of the “analog” operating modes is selected. Digital signals and analog variables are detailed in Table 47. |              |

**P315 XMDO5: Output Logic Level**

|             |                 |  |                     |
|-------------|-----------------|--|---------------------|
| <b>P315</b> | <b>Range</b>    | 0–1  | 0: FALSE<br>1: TRUE |
|             | <b>Default</b>  | 1  | 1: TRUE             |
|             | <b>Level</b>    | ENGINEERING  |                     |
|             | <b>Address</b>  | 915  |                     |
|             | <b>Function</b> | <b>XMDO5</b> digital output logic function to apply a logic reversal (negation) to the calculated output signal: (0) FALSE = a logic negation is applied; (1) TRUE = no negation is applied. |                     |

**P316 XMDO6: Signal Selection**

|             |                 |   |              |
|-------------|-----------------|---|--------------|
| <b>P316</b> | <b>Range</b>    | 0 ÷ 59  | See Table 47 |
|             | <b>Default</b>  | 0   | D0: Disable  |
|             | <b>Level</b>    | ENGINEERING   |              |
|             | <b>Address</b>  | 916   |              |
|             | <b>Function</b> | Selects the digital signal used to calculate the value of <b>XMDO6</b> digital output. It selects an analog variable used to calculate the value of <b>XMDO6</b> digital input if one of the “analog” operating modes is selected. Digital signals and analog variables are detailed in Table 47. |              |

**P317 XMDO6: Output Logic Level**

|             |                 |  |                     |
|-------------|-----------------|--|---------------------|
| <b>P317</b> | <b>Range</b>    | 0–1  | 0: FALSE<br>1: TRUE |
|             | <b>Default</b>  | 1  | 1: TRUE             |
|             | <b>Level</b>    | ENGINEERING  |                     |
|             | <b>Address</b>  | 917  |                     |
|             | <b>Function</b> | <b>XMDO6</b> digital output logic function to apply a logic reversal (negation) to the calculated output signal: (0) FALSE = a logic negation is applied; (1) TRUE = no negation is applied. |                     |

## 28. MEASURE CONTROL FROM PT100

### 28.1. Overview

This menu relates to ES847 control board. It can be viewed only if **R023** (I/O board setting) = PT100 (see the EXPANSION BOARD CONFIGURATION MENU).

The analog inputs can be linked to measure sensors.



**NOTE** Set DIP-Switches 1 and 2 as follows for proper data acquisition from PT100:

SW1

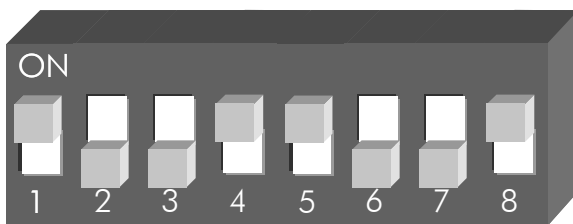

SW2

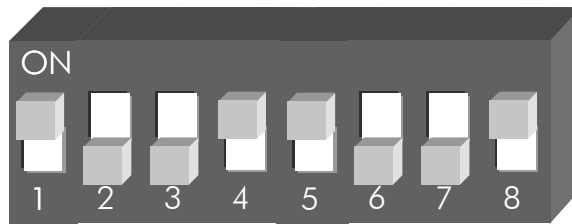

### 28.2. List of Parameters P318 to P325

Table 57: List of parameters P318 to P325

| Parameter   | FUNCTION                  | User Level | DEFAULT VALUES | MODBUS Address |
|-------------|---------------------------|------------|----------------|----------------|
| <b>P320</b> | Channel 1: measure mode   | ADVANCED   | 0: no input    | 920            |
| <b>P321</b> | Channel 1: measure offset | ADVANCED   | 0.0 °C         | 921            |
| <b>P322</b> | Channel 2: measure mode   | ADVANCED   | 0: no input    | 922            |
| <b>P323</b> | Channel 2: measure offset | ADVANCED   | 0.0 °C         | 923            |
| <b>P324</b> | Channel 3: measure mode   | ADVANCED   | 0: no input    | 924            |
| <b>P325</b> | Channel 3: measure offset | ADVANCED   | 0.0 °C         | 925            |
| <b>P326</b> | Channel 4: measure mode   | ADVANCED   | 0: no input    | 926            |
| <b>P327</b> | Channel 4: measure offset | ADVANCED   | 0.0 °C         | 927            |

**P320 Channel 1: Measure Mode**

|             |                 |   |                             |
|-------------|-----------------|---|-----------------------------|
| <b>P320</b> | <b>Range</b>    | 0 ÷ 1   | 0: no input<br>1: val PT100 |
|             | <b>Default</b>  | 0   | 0: no input                 |
|             | <b>Level</b>    | ADVANCED  |                             |
|             | <b>Address</b>  | 920   |                             |
|             | <b>Function</b> | This parameter selects the type of analog signal available in terminals 27–28 in ES847 expansion board.<br><b>0:</b> no signal is used. The P parameter relating to the analog input disappears.<br><b>1:</b> val PT100. The acquired signal is transformed into degrees centigrade.<br>See Measure <b>M069</b> . |                             |

**P321 Channel 1: Measure Offset**

|             |                 |  |                  |
|-------------|-----------------|--|------------------|
| <b>P321</b> | <b>Range</b>    | –30000 ÷ 30000   | –300.00 ÷ 300.00 |
|             | <b>Default</b>  | 0  | 0.0 °C           |
|             | <b>Level</b>    | ADVANCED   |                  |
|             | <b>Address</b>  | 921  |                  |
|             | <b>Function</b> | Value of the measure offset for channel 1: an offset can be applied to the measure to correct possible errors. |                  |

**P322 Channel 2: Measure Mode**

|             |                 |   |                             |
|-------------|-----------------|---|-----------------------------|
| <b>P322</b> | <b>Range</b>    | 0 ÷ 1   | 0: no input<br>1: val PT100 |
|             | <b>Default</b>  | 0   | 0: no input                 |
|             | <b>Level</b>    | ADVANCED  |                             |
|             | <b>Address</b>  | 922   |                             |
|             | <b>Function</b> | This parameter selects the type of analog signal available in terminals 29–30 in ES847 expansion board.<br><b>0:</b> no signal is used. The P parameter relating to the analog input disappears.<br><b>1:</b> val PT100. The acquired signal is transformed into degrees centigrade.<br>See Measure <b>M070</b> . |                             |

**P323 Channel 2: Measure Offset**

|             |                 |  |                  |
|-------------|-----------------|--|------------------|
| <b>P323</b> | <b>Range</b>    | –30000 ÷ 30000   | –300.00 ÷ 300.00 |
|             | <b>Default</b>  | 0  | 0.0 °C           |
|             | <b>Level</b>    | ADVANCED   |                  |
|             | <b>Address</b>  | 923  |                  |
|             | <b>Function</b> | Value of the measure offset for channel 2: an offset can be applied to the measure to correct possible errors. |                  |

**P324 Channel 3: Measure Mode**

|             |                 |   |                             |
|-------------|-----------------|---|-----------------------------|
| <b>P324</b> | <b>Range</b>    | 0 ÷ 1   | 0: no input<br>1: val PT100 |
|             | <b>Default</b>  | 0   | 0: no input                 |
|             | <b>Level</b>    | ADVANCED  |                             |
|             | <b>Address</b>  | 924   |                             |
|             | <b>Function</b> | This parameter selects the type of analog signal available in terminals 31–32 in ES847 expansion board.<br><b>0:</b> no signal is used. The P parameter relating to the analog input disappears.<br><b>1:</b> val PT100. The acquired signal is transformed into degrees centigrade.<br>See Measure <b>M071</b> . |                             |

**P325 Channel 3: Measure Offset**

|             |                 |  |                  |
|-------------|-----------------|--|------------------|
| <b>P325</b> | <b>Range</b>    | –30000 ÷ 30000   | –300.00 ÷ 300.00 |
|             | <b>Default</b>  | 0  | 0.0 °C           |
|             | <b>Level</b>    | ADVANCED   |                  |
|             | <b>Address</b>  | 925  |                  |
|             | <b>Function</b> | Value of the measure offset for channel 3: an offset can be applied to the measure to correct possible errors. |                  |

**P326 Channel 4: Measure Mode**

|             |                 |   |                             |
|-------------|-----------------|---|-----------------------------|
| <b>P326</b> | <b>Range</b>    | 0 ÷ 1   | 0: no input<br>1: val PT100 |
|             | <b>Default</b>  | 0   | 0: no input                 |
|             | <b>Level</b>    | ADVANCED  |                             |
|             | <b>Address</b>  | 926   |                             |
|             | <b>Function</b> | This parameter selects the type of analog signal available in terminals 33–34 in ES847 expansion board.<br><b>0:</b> no signal is used. The P parameter relating to the analog input disappears.<br><b>1:</b> val PT100. The acquired signal is transformed into degrees centigrade.<br>See Measure <b>M072</b> . |                             |

**P327 Channel 4: Measure Offset**

|             |                 |  |                  |
|-------------|-----------------|--|------------------|
| <b>P327</b> | <b>Range</b>    | –30000 ÷ 30000   | –300.00 ÷ 300.00 |
|             | <b>Default</b>  | 0  | 0.0 °C           |
|             | <b>Level</b>    | ADVANCED   |                  |
|             | <b>Address</b>  | 927  |                  |
|             | <b>Function</b> | Value of the measure offset for channel 4: an offset can be applied to the measure to correct possible errors. |                  |

## 29. FIELDBUS PARAMETERS MENU

### 29.1. Overview

This menu allows selecting the Third measure and the Fourth measure from the Fieldbus.  
 The list of the selectable measures is the same as the list in the MEASURES MENU.  
 The First measure and the Second measure are fixed (Output Current and Motor Speed) (see Exchanged P).

### 29.2. List of Parameters P330 to P331

Table 58: List of parameters P330 to P331

| Parameter | FUNCTION                         | User Level  | Default Values  | MODBUS Address |
|-----------|----------------------------------|-------------|-----------------|----------------|
| P330      | Third measure from the Fieldbus  | ENGINEERING | 13:Torque Out % | 930            |
| P331      | Fourth measure from the Fieldbus | ENGINEERING | 23: PID Out%    | 931            |

#### P330 Third Measure from the Fieldbus

| P330 | Range | Default              | Level       | Address | Function                              |
|------|-------|----------------------|-------------|---------|---------------------------------------|
|      | 0-91  | See Table 59         | ENGINEERING | 930     | Third measure exchanged via Fieldbus. |
|      |       | M012 :[Torque Out %] |             |         |                                       |

#### P331 Fourth Measure from the Fieldbus

| P331 | Range | Default           | Level       | Address | Function                               |
|------|-------|-------------------|-------------|---------|--|
|      | 0-91  | See Table 59      | ENGINEERING | 931     | Fourth measure exchanged via Fieldbus. |
|      |       | M022 :[PID Out %] |             |         |  |

Table 59: List of the programmable measures in P330 to P331 and P268, P268a, P268b, P268c, P268d

|    |                       |    |                        |
|----|-----------------------|----|------------------------|
| 0  | NONE                  | 47 | M046 SerPID Ref        |
| 1  | M000 Speed Ref        | 48 | M047 FbusPID Ref       |
| 2  | M001 dcm.Spd.Ref      | 49 | M048 SerPID Fbk        |
| 3  | M002 Ramp Out         | 50 | M049 FbusPID Fbk       |
| 4  | M003 dcm.Rmp.Out      | 51 | M050 Encoder Ref       |
| 5  | M004 Motor Speed      | 52 | M051 Freq.In Ref       |
| 6  | M005 dcm.Mot.Spd      | 53 | M052 Op.Time Lo        |
| 7  | M006 Mot.Freq.        | 54 | M053 Op.Time Hi        |
| 8  | M007 Torq.Ref         | 55 | M054 Sply.Time Lo      |
| 9  | M008 Torq.Demand      | 56 | M055 Sply.Time Hi      |
| 10 | M009 Torq.Out         | 57 | M056 Digital Out       |
| 11 | M010 Torq.Ref %       | 58 | M057 Freq.Out          |
| 12 | M011 Torq.Dem.%       | 59 | M058 Analog Out AO1    |
| 13 | M012 Torq.Out %       | 60 | M059 Analog Out AO2    |
| 14 | M013 T.Lim.Ref        | 61 | M060 Analog Out AO3    |
| 15 | M014 T.Lim.RmpOut     | 62 | M061 Aux. Dig.OUT      |
| 16 | M015 T.Lim.Ref %      | 63 | M062 Amb.Temp.         |
| 17 | M016 T.Lim.RmpOut %   | 64 | M036a Aux.Ser. Dig.IN  |
| 18 | M017 Flux Ref         | 65 | M064 Hts.Temp.         |
| 19 | M018 PID Ref %        | 66 | M065 OP Counter        |
| 20 | M019 PID RmpOut %     | 67 | M066 SP Counter        |
| 21 | M020 PID Fbk %        | 68 | M036b Aux.FBus. Dig.IN |
| 22 | M021 PID Err %        | 69 | M022a PID2 Out %       |
| 23 | M022 PID Out %        | 70 | M069 PT100 Temp.1      |
| 24 | M023 PID Ref          | 71 | M070 PT100 Temp.2      |
| 25 | M024 PID Fbk          | 72 | M071 PT100 Temp.3      |
| 26 | M056a Virtual Dig.Out | 73 | M072 PT100 Temp.4      |
| 27 | M026 Mot.Current      | 74 | M073 -----             |
| 28 | M027 Out Volt         | 75 | M074 -----             |
| 29 | M028 Power Out        | 76 | M075 -----             |
| 30 | M029 Vbus-DC          | 77 | M076 -----             |
| 31 | M030 V Mains          | 78 | M077 -----             |
| 32 | M031 Delay.Dig.IN     | 79 | M026a I2t              |
| 33 | M032 Istant.Dig.IN    | 80 | M039a Analog In XAIN4  |
| 34 | M033 Term. Dig.IN     | 81 | M039b Analog In XAIN5  |
| 35 | M034 Ser. Dig.IN      | 82 | M018a PID2 Ref %       |
| 36 | M035 Fbus. Dig.IN     | 83 | M019a PID2 RmpOut %    |
| 37 | M036 Aux. Dig.IN      | 84 | M020a PID2 Fbk %       |
| 38 | M037 Analog In REF    | 85 | M084 -----             |
| 39 | M038 Analog In AIN1   | 86 | M085 -----             |
| 40 | M039 Analog In AIN2   | 87 | M021a PID2 Err %       |
| 41 | M040 Ser.SpdRef       | 88 | M023a PID2 Ref         |
| 42 | M041 dcm.Ser.SpdRef   | 89 | M024a PID2 Fbk         |
| 43 | M042 Fbus.SpdRef      | 90 | M089 Status            |
| 44 | M043 dcm.Fbus.SpdRef  | 91 | M090 Alarm             |
| 45 | M044 Ser.TrqLimRef    | 92 | M056b Timed Flags TFL  |
| 46 | M045 Fbus.TrqLimRef   |    |                        |

## 30. VIRTUAL DIGITAL OUTPUTS (MPL) MENU

### 30.1. Overview

The Virtual Digital Outputs menu includes the parameters allowing configuring the virtual digital outputs (MPL1..4) of the Sinus Penta drive.

Virtual digital outputs are logic blocks (no hardware output is provided) allocating more complex logic functions to outputs MDO1..4: MPL virtual outputs can be feedbacked at the input of a new block (hardware or virtual block), thus allowing implementing more complex functionality.



**NOTE** The Virtual Digital Outputs menu may be accessed only if the user level is **ADVANCED** or **ENGINEERING**.



**NOTE** XMDI auxiliary digital outputs (values from 13 to 20 in the parameters relating to the control functions) can be set up only after setting XMDI/O in parameter **R023**.

#### 30.1.1. FACTORY SETTING

The four virtual digital outputs are disabled as a factory setting.

#### 30.1.2. STRUCTURE OF THE VIRTUAL DIGITAL OUTPUTS

A virtual digital output is composed of two logic blocks allowing data processing before actuating the actual digital output. Block 2 depends on the settings in parameters **P357a** (**P366a**, **P375a**, **P384a**).

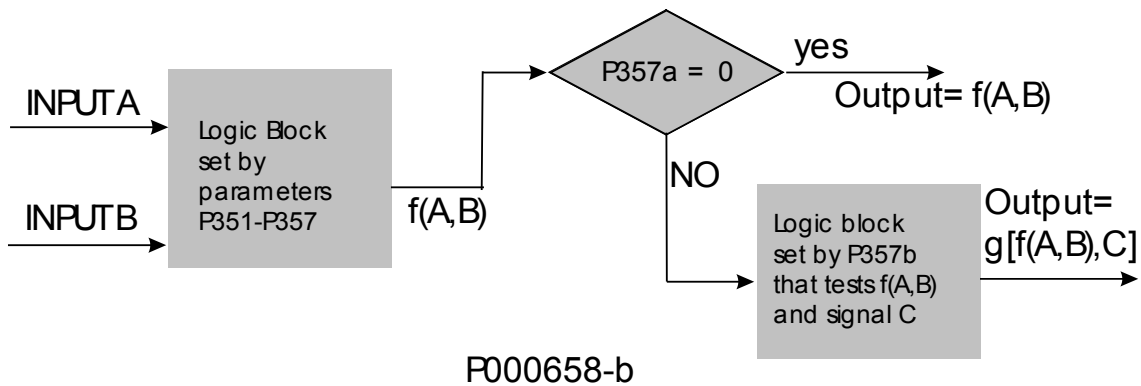

Figure 38: Block diagram of the virtual digital outputs (MPL)

#### Operating modes set in MPL1 (2, 3, 4): P350, (P359, P368, P377)

The user can select one of the following operating modes:

Table 60: Digital Output Modes

|                       |  |
|-----------------------|--|
| <b>DISABLING</b>      | The selected digital output is disabled.   |
| <b>DIGITAL</b>        | The digital output depends on a selected digital signal and on the logic output function (True/False).   |
| <b>DOUBLE DIGITAL</b> | The digital output depends on 2 selected digital signals, on the logic function calculating the output value and on the logic output function (True/False).  |
| <b>ANALOG</b>         | The digital output depends on a selected analog variable, which is tested through Test A and Test B, thus obtaining 2 digital signals; starting from their value, the selected logic function calculates the output value, whereas the True/False logic output function calculates the end value.  |
| <b>DOUBLE ANALOG</b>  | The digital outputs depends on 2 selected analog variables: Test A is performed for variable A, whilst Test B is performed for variable B, thus obtaining 2 digital signals; starting from their value, the selected logic function calculates the output value, whereas the logic output function True/False calculates the end value.  |
| <b>DOUBLE FULL</b>    | As DOUBLE ANALOG or DOUBLE DIGITAL mode, but both digital signals and analog variables can be selected.<br>If you select a digital signal, its value (TRUE or FALSE) is used to calculate the selected logic function.<br>If you select an analog variable, the test selected for this variable is performed, and its result (TRUE or FALSE) is used to calculate the selected logic function. |
| <b>BRAKE (*)</b>      | As ABS BRAKE below, although the selected variables are not expressed as absolute values, but depend on the selected tests.  |
| <b>ABS BRAKE (*)</b>  | The ABS BRAKE mode allows controlling the electromechanical brake of a motor used for lifting applications. The ABS BRAKE mode is applied by selecting the measured (or estimated) speed value [A71] as the first variable and the output torque [A80] as the second variable. Variables are considered as absolute values.  |
| <b>ABS LIFT (*)</b>   | As ABS BRAKE, but the brake unlocks (digital output open) when a given torque value is attained, which is automatically determined based on the last torque value required in the previous stroke.   |

(\*) The activation and deactivation of the outputs programmed as **BRAKE**, **ABS BRAKE** and **ABS LIFT** is affected also by other conditions depending on the drive status. Namely:

|                     |  |
|---------------------|--|
| <b>Activation</b>   | Conditions to be considered in logic AND with the following programmed functions: <ul style="list-style-type: none"> <li>• Drive accelerating or in pre-tensioning mode (see BRIDGE CRANE MENU).</li> <li>• Drive running, no alarm triggered</li> </ul>   |
| <b>Deactivation</b> | Conditions to be considered in logic OR with the following programmed functions: <ul style="list-style-type: none"> <li>• Drive not running or locked due to an alarm condition</li> <li>• Drive in tracking error mode (see ENCODER/FREQUENCY INPUTS MENU), unless parameter <b>C303</b> is set to NO (see BRIDGE CRANE MENU).</li> </ul> |

#### **Variable A Selected for MPL1 (2, 3, 4): P351, (P360, P369, P378)**

Selects the digital signal or the analog variable used for Test A (set with **P353 / P362 / P371 / P380**).

The whole list of the selectable items and their description are stated in Table 47.

If a digital signal is selected, Test A is not performed: therefore, the comparison value for Test A (set with **P355 / P364 / P373 / P382**) has no meaning.



#### **NOTE**

This parameter can be accessed only if the operating mode of the digital output concerned is other than zero. Example: MPL1 **P350**≠0.

**Variable B selected for MPL1 (2, 3, 4): P352, (P361, P370, P379)**

This selects a different digital signal or the analog variable used for Test B (set with **P354 / P363 / P372 / P381**). The whole list of the selectable items and their description are stated in Table 47.

If a digital signal is selected, Test B is not performed: therefore, the comparison value for Test B (set with **P356 / P365 / P374 / P383**) has no meaning.



**NOTE**

Parameter **P352** cannot be accessed when the digital output operating mode is 1: DIGITAL or 3: ANALOG.

Example: MPL1 **P350**=1 OR **P350**=3.

**Testing Variable A for MPL1 (2, 3, 4): P353, (P362, P371, P380)**

If an analog variable is selected, a logic TEST is performed to obtain a TRUE/FALSE Boolean signal. Eight different tests are available, that can be performed for selected variable A and its comparing value A:

**Table 61: Test functions**

|                            |  |
|----------------------------|--|
| GREATER THAN               | Selected variable > comparing value                  |
| GREATER THAN/EQUAL TO      | Selected variable ≥ comparing value                  |
| LOWER                      | Selected variable < comparing value                  |
| LOWER THAN/EQUAL TO        | Selected variable ≤ comparing value                  |
| ABS, GREATER THAN          | Absolute value (selected variable) > comparing value |
| ABS, GREATER THAN/EQUAL TO | Absolute value (selected variable) ≥ comparing value |
| ABS, LOWER                 | Absolute value (selected variable) < comparing value |
| ABS, LOWER THAN/EQUAL TO   | Absolute value (selected variable) ≤ comparing value |



**NOTE**

This parameter can be accessed only if the operating mode of the selected digital output is > 2. Example: MPL1 **P350**>2.

**Operation on variable B, digital output MPL1 (2, 3, 4): P354, (P363, P372, P381)**

If an analog variable is selected, a logic TEST is performed to obtain a TRUE/FALSE Boolean signal. Eight different tests are available, that can be performed for selected variable B and its comparing value B (see Table 61).



**NOTE**

This parameter can be accessed only if the operating mode of the selected digital output is > 2 and < 9. Example: MPL1 2<**P350**<9.

**Reference threshold for P351 ( P360, P369, P378) in MPL1 (2, 3, 4): P355, (P364, P373, P382)**

Defines the comparing value of Test A with the first selected variable.



**NOTE**

This parameter can be accessed only if the operating mode of the selected digital output is > 2. Example: MPL1 **P350**>2.

**Reference threshold for P352 ( P361, P370, P379) in MPL1 (2, 3, 4): P356, (P365, P374, P383)**

Defines the comparing value of Test B with the first selected variable.



**NOTE**

This parameter can be accessed only if the operating mode of the selected digital output is > 2. Example: MPL1 **P350**>2.

**MPL1 (2, 3, 4): Function applied to the result of Tests A and B: P357, (P366, P375, P384)**

A logic function is applied to the two Boolean signals obtained in order to obtain the output TRUE/FALSE Boolean signal.

Six different tests may be performed for variable (A) using the comparing value and variable (B).

**(A) OR (B):** The selected digital output is enabled when at least one of the two conditions below is true (this function also allows enabling the selected digital input based on one test only).

| <b>(A) OR (B)</b> |        |        |
|-------------------|--------|--------|
| Test A            | Test B | Output |
| 0                 | 0      | 0      |
| 1                 | 0      | 1      |
| 0                 | 1      | 1      |
| 1                 | 1      | 1      |

**(A) SET (B) RESET Rising Edge**

**(A) RESET (B) SET Rising Edge**

**(A) SET (B) RESET Falling Edge**

**(A) RESET (B) SET Falling Edge**

The selected digital output is activated as the output of a Flip Flop Set Reset whose inputs are signal A and signal B. This function can be used in case of hysteresis.

The status of the input (Q<sub>n</sub>) depends on the previous value (Q<sub>n-1</sub>) and on the result of the two tests.

Signals A and B are considered only when passing from 0→1 (Rising Edge) or 1→0 (Falling Edge) and may be used both as Set and Reset command.

Example: Suppose that the output enables only when the motor speed exceeds 50rpm and disables when the motor speed drops below 5 rpm. To do so, assign the first condition to Test A, representing the Set command for Flip Flop (P351 = Motor Speed, P353 >, P355 = 50rpm), and assign the second condition to Test B, representing the Reset command (P352 = Motor Speed, P354 ≤, P356 = 5rpm). A more detailed example is given at the end of this section.

| <b>(A) SET (B) RESET Rising Edge</b> |                |                  |
|--------------------------------------|----------------|------------------|
| Test A (Set)                         | Test B (Reset) | Q <sub>n</sub>   |
| 0→1                                  | X              | 1                |
| X                                    | 0→1            | 0                |
| In any other case                    |                | Q <sub>n-1</sub> |

| <b>(A) RESET (B) SET Rising Edge</b> |              |                  |
|--------------------------------------|--------------|------------------|
| Test A (Reset)                       | Test B (Set) | Q <sub>n</sub>   |
| 0→1                                  | X            | 0                |
| X                                    | 0→1          | 1                |
| In any other case                    |              | Q <sub>n-1</sub> |

| <b>(A) SET (B) RESET Falling Edge</b> |                |                  |
|---------------------------------------|----------------|------------------|
| Test A (Set)                          | Test B (Reset) | Q <sub>n</sub>   |
| 1→0                                   | X              | 1                |
| X                                     | 1→0            | 0                |
| In any other case                     |                | Q <sub>n-1</sub> |

| <b>(A) RESET (B) SET Falling Edge</b> |              |                  |
|---------------------------------------|--------------|------------------|
| Test A (Reset)                        | Test B (Set) | Q <sub>n</sub>   |
| 1→0                                   | X            | 0                |
| X                                     | 1→0          | 1                |
| In any other case                     |              | Q <sub>n-1</sub> |

**(A) AND (B):** The selected digital output enables when both conditions are true.

| <b>(A) AND (B)</b> |        |        |
|--------------------|--------|--------|
| Test A             | Test B | Output |
| 0                  | 0      | 0      |
| 1                  | 0      | 0      |
| 0                  | 1      | 0      |
| 1                  | 1      | 1      |

**(A) XOR (B):** The selected digital output enables when either one condition or the other is true (but not when both conditions are true at a time).

| <b>(A) XOR (B)</b> |        |        |
|--------------------|--------|--------|
| Test A             | Test B | Output |
| 0                  | 0      | 0      |
| 1                  | 0      | 1      |
| 0                  | 1      | 1      |
| 1                  | 1      | 0      |

**(A) NOR (B):** The selected digital output enables when no condition is true. The NOR function between two variables corresponds to the AND of the same false variables, i.e.  $(A) \text{ NOR } (B) = (\overline{A}) \text{ AND } (\overline{B})$ .

| <b>(A) NOR (B)</b> |        |        |
|--------------------|--------|--------|
| Test A             | Test B | Output |
| 0                  | 0      | 1      |
| 1                  | 0      | 0      |
| 0                  | 1      | 0      |
| 1                  | 1      | 0      |

**(A) NAND (B):** The selected digital output enables when no condition is true or when only one of the two conditions is true. The NAND function between two variables corresponds to the OR of the same false variables, i.e.  $(A) \text{ NAND } (B) = (\overline{A}) \text{ OR } (\overline{B})$ .

| <b>(A) NAND (B)</b> |        |        |
|---------------------|--------|--------|
| Test 1              | Test 2 | Output |
| 0                   | 0      | 1      |
| 1                   | 0      | 1      |
| 0                   | 1      | 1      |
| 1                   | 1      | 0      |



**NOTE**

This parameter can be accessed only if the operating mode of the selected digital output is > 2 and <9. Example: MPL1 2<P350<9.

**Function applied to the result of f(A,B) C for MPL1: P357b, (P366b, P375b, P384b)**

Once the Boolean signal resulting from f(A,B) is obtained, an additional logic function can be applied to obtain the output TRUE//FALSE Boolean signal.

If parameter **P357a** is disabled, the output of f(A,B) goes directly to the corresponding digital output; if parameter **P357a** is enabled, the output of the output of f(A,B) becomes one of the two inputs of the second programmed block.

The user can choose one of the six Boolean tests above for the first variable—f(A,B)—and for the second variable (C).

**Logic applied to MPL1 (2, 3,4): P358, (P367, P376, P385)**

The logic of the Boolean signal can be reversed at the end of the processing chain.

The user can choose whether the logic level of the digital output is POSITIVE or NEGATIVE.

(0) FALSE = a logic negation is applied (NEGATIVE logic).

(1) TRUE = no negation is applied (POSITIVE logic).

**NOTE**

This parameter can be accessed only if the operating mode of the selected digital output is other than zero. Example: MPL1 **P350**≠0

**NOTE**

Please refer to Programmable Operating Modes (Diagrams) relating to the digital outputs.

## 30.2. Operating Diagram of the Virtual Digital Outputs

---

Virtual digital outputs are software outputs that can be used as digital inputs from the following items:

- digital inputs
- digital outputs
- auxiliary digital outputs
- virtual digital outputs themselves.

They can be used for special functionality of the system, thus avoiding loop wiring on the same control board.

Example:

It can be necessary to control the status of the physical **ENABLE** contacts (**ENABLE-A** and **ENABLE-B**) of the system to cause an external alarm to trip when MPL1 is selected in parameter **C164** (DIGITAL INPUTS MENU).

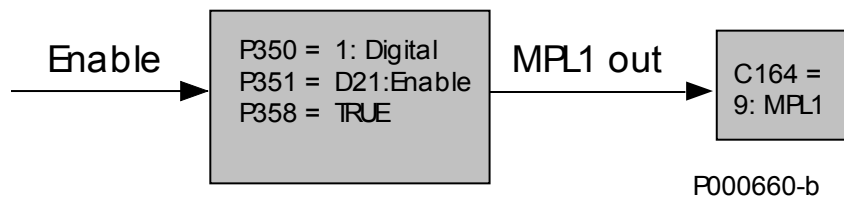

**Figure 39: Example of MPL functionality**

For more details about possible configurations of the virtual digital outputs, see Programmable Operating Modes (Diagrams).

## Examples

This section covers some examples for the supervision of pumping systems with the PID control algorithm. The settings of the parameters being used are given in the tables below: the parameters highlighted in grey have no effect.

### Example 1: Dry Run Detection

For most pumps, especially submersible bore-hole pumps, it must be assured that the pump is stopped in case of dry run. This is assured by the Dry Run Detection feature. How Does It Work?

Dry run detection is based on power/frequency monitoring. Stop (trip) due to dry run is initiated under the following conditions:

**Table 62: MPL parameterization for Dry Run Detection**

|              |   |                        |
|--------------|---|------------------------|
| <b>P359</b>  | MPL2: Digital output mode                           | DOUBLE ANALOG          |
| <b>P360</b>  | MPL2: Selecting variable A                          | A77: Output Power      |
| <b>P361</b>  | MPL2: Selecting variable B                          | A86: PID Feedback      |
| <b>P362</b>  | MPL2: Testing variable A                            | <                      |
| <b>P363</b>  | MPL2: Testing variable B                            | <                      |
| <b>P364</b>  | MPL2: Comparing value for Test A                    | Min. operating PWR [*] |
| <b>P365</b>  | MPL2: Comparing value for Test B                    | Min. FBK value [*]     |
| <b>P366</b>  | MPL2: Function applied to the result of the 2 tests | (A) AND (B)            |
| <b>P366a</b> | MPL2: Selecting variable C                          | D11: PID Out Max       |
| <b>P366b</b> | MPL2: Function applied to the result of f(A,B) C    | f(A,B) AND (C)         |
| <b>P367</b>  | MPL2: Output logic level                            | TRUE                   |



**NOTE** It is recommended that a TIMEOUT be entered for Dry Run Detection. Enter a timeout for MPL2 output (see TIMERS MENU).

|              |   |                        |
|--------------|---|------------------------|
| <b>P368</b>  | MPL3: Digital output mode                           | DOUBLE ANALOG          |
| <b>P369</b>  | MPL3: Selecting variable A                          | A77: Output Power      |
| <b>P370</b>  | MPL3: Selecting variable B                          | A86: PID Feedback      |
| <b>P371</b>  | MPL3: Testing variable A                            | ≥                      |
| <b>P372</b>  | MPL3: Testing variable B                            | <                      |
| <b>P373</b>  | MPL3: Comparing value for Test A                    | Min. operating PWR [*] |
| <b>P374</b>  | MPL3: Comparing value for Test B                    | Min. FBK value [*]     |
| <b>P375</b>  | MPL3: Function applied to the result of the 2 tests | (A) AND (B)            |
| <b>P375a</b> | MPL3: Selecting variable C                          | D51: MPL2              |
| <b>P375b</b> | MPL3: Function applied to the result of f(A,B) C    | f(A,B) OR (C)          |
| <b>P376</b>  | MPL3: Output logic level                            | TRUE                   |



**NOTE** MPL3 detects when piping is clogged or faulty or when the delivery/pressure sensor is malfunctioning (e.g. the pump membrane is locked) when the sensor is located downstream of the mains.

|              |   |                           |
|--------------|---|---------------------------|
| <b>P377</b>  | MPL4: Digital output mode                           | DOUBLE FULL               |
| <b>P378</b>  | MPL4: Selecting variable A                          | D51: MPL3                 |
| <b>P379</b>  | MPL4: Selecting variable B                          | A86: PID Feedback         |
| <b>P380</b>  | MPL4: Testing variable A                            |                           |
| <b>P381</b>  | MPL4: Testing variable B                            | ≥                         |
| <b>P382</b>  | MPL4: Comparing value for Test A                    |                           |
| <b>P383</b>  | MPL4: Comparing value for Test B                    | Min. FBK value <b>[*]</b> |
| <b>P384</b>  | MPL4: Function applied to the result of the 2 tests | (A) Set (B) Reset         |
| <b>P384a</b> | MPL4: Selecting variable C                          | D0: Disabled              |
| <b>P384b</b> | MPL4: Function applied to the result of f(A,B) C    |                           |
| <b>P385</b>  | MPL4: Output logic level                            | See steps 1. and 2. below |

Virtual digital output MPL4 locks the system operation in two modes:

1. Virtually connecting the output to an external alarm input (**P385**=FALSE; **C164**=12: MPL4)
2. Disabling the PID (**P385**=TRUE; **C171**=12: MPL4)

On the other hand, when the malfunctioning signal is sent to the PLC supervisor, the same parameterization in MPL4 shall be entered in the digital output concerned.



**NOTE** **[\*]**  
 Min. Operating PWR = Min. power required for the pump delivery.

Min. FBK value = the min. feedback value shall be ≥ **P237** (minimum PID).



**NOTE**  
 When the Sleep Mode (see PID PARAMETERS MENU) and the Dry Run Detection mode are activated simultaneously, the delay time for the Dry Run Detection mode shall be shorter than the Sleep Mode time.

**Example 2: Pipe Fill Function.**

The PIPE FILL function avoids water hammer in irrigation pipes. To avoid water hammer, pipes must be filled very slowly for air drainage. To do so, force a minimum rate reference, thus obtaining the minimum delivery of the pumping system. Once the min. rate is attained, the feedback starts increasing; when the filling pressure is attained, the system can start operating under normal conditions. Suppose that the feedback value of the pipe pressure is present at analog input AIN1.

**Table 63: MPL parameterization for Pipe Fill function**

|              |   |   |
|--------------|---|---|
| <b>P368</b>  | MPL3: Digital output mode                           | DOUBLE ANALOG                           |
| <b>P369</b>  | MPL3: Selecting variable A                          | A79: AIN1                               |
| <b>P370</b>  | MPL3: Selecting variable B                          | A79: AIN1                               |
| <b>P371</b>  | MPL3: Testing variable A                            | <                                       |
| <b>P372</b>  | MPL3: Testing variable B                            | ≥                                       |
| <b>P373</b>  | MPL3: Comparing value for Test A                    | Pressure value when the system is empty |
| <b>P374</b>  | MPL3: Comparing value for Test B                    | Pressure value when the system is full  |
| <b>P375</b>  | MPL3: Function applied to the result of the 2 tests | (A) Set (B) Reset                       |
| <b>P375a</b> | MPL3: Selecting variable C                          | D0: Disabled                            |
| <b>P375b</b> | MPL3: Function applied to the result of f(A,B) C    |   |
| <b>P376</b>  | MPL3: Output logic level                            | TRUE                                    |
| <b>P377</b>  | MPL4: Digital output mode                           | DIGITAL                                 |
| <b>P378</b>  | MPL4: Selecting variable A                          | D52: MPL3                               |
| <b>P379</b>  | MPL4: Selecting variable B                          |   |
| <b>P380</b>  | MPL4: Testing variable A                            |   |
| <b>P381</b>  | MPL4: Testing variable B                            |   |
| <b>P382</b>  | MPL4: Comparing value for Test A                    |   |
| <b>P383</b>  | MPL4: Comparing value for Test B                    |   |
| <b>P384</b>  | MPL4: Function applied to the result of the 2 tests |   |
| <b>P384a</b> | MPL4: Selecting variable C                          | D0: Disabled                            |
| <b>P384b</b> | MPL4: Function applied to the result of f(A,B) C    |   |
| <b>P385</b>  | MPL4: Output logic level                            | TRUE                                    |
| <b>P009</b>  | Acceleration time 1                                 | Ramp for normal operation [*]           |
| <b>P010</b>  | Deceleration time 1                                 | Ramp for normal operation [*]           |
| <b>P011</b>  | Acceleration time 2                                 | Ramp for PIPE FILL [*]                  |
| <b>P012</b>  | Deceleration time 2                                 | Ramp for PIPE FILL [*]                  |
| <b>P080</b>  | Multispeed function                                 | 0: Preset Speed                         |
| <b>P081</b>  | Output speed 1 (Mspd1)                              | Min. operating speed [*]                |
| <b>C182</b>  | MDI Multiprogramming enable                         | Enabled                                 |
| <b>C155</b>  | MDI for multispeed 0 selection                      | 12: MPL4                                |
| <b>C167</b>  | MDI for multiramp 0 selection                       | 11: MPL3                                |
| <b>C171</b>  | MDI for PID disable                                 | 11: MPL3                                |

It is required to repeat MPL3 output to MPL4 output, because every MPL may be allocated to maximum 2 functions (**C182 = Enabled** – see DIGITAL INPUTS MENU). In that case, 3 functions are required, so an additional output is needed.

**NOTE**

[\*]

Ramp for normal function = Ramp desired during normal operation.

Ramp for PIPE FILL = Ramp desired when filling the pipes.

Minimum operating speed = Min. speed required for the correct delivery of the pump.

### 30.3. List of Parameters P350 to P385

Table 64: List of parameters P350 to P385

| Parameter | FUNCTION  | User Level | DEFAULT VALUES | MODBUS Address |
|-----------|---|------------|----------------|----------------|
| P350      | MPL1: Digital output mode                           | ADVANCED   | 0: DISABLE     | 950            |
| P351      | MPL1: Selecting variable A                          | ADVANCED   | D21: ENABLE    | 951            |
| P352      | MPL1: Selecting variable B                          | ADVANCED   | D0: DISABLE    | 952            |
| P353      | MPL1: Testing variable A                            | ADVANCED   | 0: >           | 953            |
| P354      | MPL1: Testing variable B                            | ADVANCED   | 0: >           | 954            |
| P355      | MPL1: Comparing value for Test A                    | ADVANCED   | 0              | 955            |
| P356      | MPL1: Comparing value for Test B                    | ADVANCED   | 0              | 956            |
| P357      | MPL1: Function applied to the result of the 2 tests | ADVANCED   | 0: (A) OR (B)  | 957            |
| P357a     | MPL1: Selecting variable C                          | ADVANCED   | 0: Disable     | 932            |
| P357b     | MPL1: Function applied to the result of f(A,B) C    | ADVANCED   | 0: f(A,B) OR C | 933            |
| P358      | MPL1: Output logic level                            | ADVANCED   | 1: TRUE        | 958            |
| P359      | MPL2: Digital output mode                           | ADVANCED   | 0: DISABLE     | 959            |
| P360      | MPL2: Selecting variable A                          | ADVANCED   | D0: DISABLE    | 960            |
| P361      | MPL2: Selecting variable B                          | ADVANCED   | D0: DISABLE    | 961            |
| P362      | MPL2: Testing variable A                            | ADVANCED   | 0: >           | 962            |
| P363      | MPL2: Testing variable B                            | ADVANCED   | 0: >           | 963            |
| P364      | MPL2: Comparing value for Test A                    | ADVANCED   | 0              | 964            |
| P365      | MPL2: Comparing value for Test B                    | ADVANCED   | 0              | 965            |
| P366      | MPL2: Function applied to the result of the 2 tests | ADVANCED   | 0: (A) OR (B)  | 966            |
| P366a     | MPL2: Selecting variable C                          | ADVANCED   | 0: Disable     | 934            |
| P366b     | MPL2: Function applied to the result of f(A,B) C    | ADVANCED   | 0: f(A,B) OR C | 935            |
| P367      | MPL2: Output logic level                            | ADVANCED   | 1: TRUE        | 967            |
| P368      | MPL3: Digital output mode                           | ADVANCED   | 0: DISABLE     | 968            |
| P369      | MPL3: Selecting variable A                          | ADVANCED   | D0: DISABLE    | 969            |
| P370      | MPL3: Selecting variable B                          | ADVANCED   | D0: DISABLE    | 970            |
| P371      | MPL3: Testing variable A                            | ADVANCED   | 0: >           | 971            |
| P372      | MPL3: Testing variable B                            | ADVANCED   | 0: >           | 972            |
| P373      | MPL3: Comparing value for Test A                    | ADVANCED   | 0              | 973            |
| P374      | MPL3: Comparing value for Test B                    | ADVANCED   | 0              | 974            |
| P375      | MPL3: Function applied to the result of the 2 tests | ADVANCED   | 0: (A) OR (B)  | 975            |
| P375a     | MPL3: Selecting variable C                          | ADVANCED   | 0: Disable     | 936            |
| P375b     | MPL3: Function applied to the result of f(A,B) C    | ADVANCED   | 0: f(A,B) OR C | 937            |
| P376      | MPL3: Output logic level                            | ADVANCED   | 1: TRUE        | 976            |
| P377      | MPL4: Digital output mode                           | ADVANCED   | 0: DISABLE     | 977            |
| P378      | MPL4: Selecting variable A                          | ADVANCED   | D0: DISABLE    | 978            |
| P379      | MPL4: Selecting variable B                          | ADVANCED   | D0: DISABLE    | 979            |
| P380      | MPL4: Testing variable A                            | ADVANCED   | 0: >           | 980            |
| P381      | MPL4: Testing variable B                            | ADVANCED   | 0: >           | 981            |
| P382      | MPL4: Comparing value for Test A                    | ADVANCED   | 0              | 982            |
| P383      | MPL4: Comparing value for Test B                    | ADVANCED   | 0              | 983            |
| P384      | MPL4: Function applied to the result of the 2 tests | ADVANCED   | 0: (A) OR (B)  | 984            |
| P384a     | MPL4: Selecting variable C                          | ADVANCED   | 0: Disable     | 938            |
| P384b     | MPL4: Function applied to the result of f(A,B) C    | ADVANCED   | 0: f(A,B) OR C | 939            |
| P385      | MPL4: Output logic level                            | ADVANCED   | 1: TRUE        | 985            |

**P350 MPL1: Digital Output Mode**

|             |                 |   |   |
|-------------|-----------------|---|---|
| <b>P350</b> | <b>Range</b>    | 0 ÷ 8   | 0: DISABLE<br>1: DIGITAL<br>2: DOUBLE DIGITAL<br>3: ANALOG<br>4: DOUBLE ANALOG<br>5: DOUBLE FULL<br>6: BRAKE<br>7: ABS BRAKE<br>8: ABS LIFT |
|             | <b>Default</b>  | 1   | 1: DIGITAL  |
|             | <b>Level</b>    | ADVANCED  |   |
|             | <b>Address</b>  | 950   |   |
|             | <b>Function</b> | This parameter defines the operating mode of <b>virtual digital output 1</b> .<br>The different operating modes are described at the beginning of this chapter. |   |



**NOTE**

MPL1 Digital output can be programmed only if the frequency output is not set up: **P200** = Disable (see ANALOG AND FREQUENCY OUTPUTS MENU).

**P351 MPL1: Selecting Variable A**

|             |                 |   |              |
|-------------|-----------------|---|--------------|
| <b>P351</b> | <b>Range</b>    | 0 ÷ 119   | See Table 47 |
|             | <b>Default</b>  | 21  | D21: Enable  |
|             | <b>Level</b>    | ADVANCED  |              |
|             | <b>Address</b>  | 951   |              |
|             | <b>Function</b> | This parameter selects the digital signal used to calculate the value of <b>MPL1</b> digital output.<br>It selects an analog variable used to calculate the value of <b>MPL1</b> digital output if one of the “analog” operating modes is selected.<br>Digital signals and analog variables are detailed in Table 47. |              |

**P352 MPL1: Selecting Variable B**

|             |                 |   |              |
|-------------|-----------------|---|--------------|
| <b>P352</b> | <b>Range</b>    | 0 ÷ 119   | See Table 47 |
|             | <b>Default</b>  | 0   | D0: Disable  |
|             | <b>Level</b>    | ADVANCED  |              |
|             | <b>Address</b>  | 952   |              |
|             | <b>Function</b> | This parameter selects the second digital signal used to calculate the value of <b>MPL1</b> digital output.<br>It selects an analog variable used to calculate the value of <b>MPL1</b> digital input if one of the “analog” operating modes is selected.<br>Digital signals and analog variables are detailed in Table 47. |              |

**P353 MPL1: Testing Variable A**

|             |                 |  |  |
|-------------|-----------------|--|--|
| <b>P353</b> | <b>Range</b>    | 0 ÷ 7  | 0: ><br>1: ≥<br>2: <<br>3: ≤<br>4: ABS(x) ><br>5: ABS(x) ≥<br>6: ABS(x) <<br>7: ABS(x) ≤ |
|             | <b>Default</b>  | 0  | 0: >   |
|             | <b>Level</b>    | ADVANCED   |  |
|             | <b>Address</b>  | 953  |  |
|             | <b>Function</b> | This parameter defines the test to be performed for the variable detected by <b>P351</b> using <b>P355</b> as a comparing value. |  |

**P354 MPL1: Testing Variable B**

|             |                 |  |  |
|-------------|-----------------|--|--|
| <b>P354</b> | <b>Range</b>    | 0 ÷ 7  | 0: ><br>1: ≥<br>2: <<br>3: ≤<br>4: ABS(x) ><br>5: ABS(x) ≥<br>6: ABS(x) <<br>7: ABS(x) ≤ |
|             | <b>Default</b>  | 0  | 0: >   |
|             | <b>Level</b>    | ADVANCED   |  |
|             | <b>Address</b>  | 954  |  |
|             | <b>Function</b> | This parameter defines the test to be performed for the variable detected by <b>P352</b> using <b>P356</b> as a comparing value. |  |

**P355 MPL1: Comparing Value for Test A**

|             |                 |   |  |
|-------------|-----------------|---|--|
| <b>P355</b> | <b>Range</b>    | -32000 ÷ 32000  | -320.00 % ÷ 320.00 %<br>% of the full-scale value of selected variable A, see Table 47 |
|             | <b>Default</b>  | 0   | 0  |
|             | <b>Level</b>    | ADVANCED  |  |
|             | <b>Address</b>  | 955   |  |
|             | <b>Function</b> | This parameter defines the comparing value with the selected variable for test A. |  |

**P356 MPL1: Comparing Value for Test B**

|             |                 |   |  |
|-------------|-----------------|---|--|
| <b>P356</b> | <b>Range</b>    | -32000 ÷ 32000  | -320.00 % ÷ 320.00 %<br>% of the full-scale value of selected variable B, see Table 47 |
|             | <b>Default</b>  | 0   | 0  |
|             | <b>Level</b>    | ADVANCED  |  |
|             | <b>Address</b>  | 956   |  |
|             | <b>Function</b> | This parameter defines the comparing value with the selected variable for test B. |  |

**P357 MPL1: Function Applied to the Result of the 2 Tests**

|             |                 |  |   |
|-------------|-----------------|--|---|
| <b>P357</b> | <b>Range</b>    | 0 ÷ 12   | 0: (A) OR (B)<br>1: (A) SET (B) RESET<br>2: (A) AND (B)<br>3: (A) XOR (B)<br>4: (A) NOR (B)<br>5: (A) NAND (B)<br>6: (A\ OR (B)<br>7: (A) OR (B\<br>8: (A\ AND (B)<br>9: (A) AND (B\<br>10: (A) RESET (B) SET RISING EDGE<br>11: (A) SET (B) RESET FALLING EDGE<br>12: (A) RESET (B) SET FALLING EDGE |
|             | <b>Default</b>  | 0  | 0: (A) OR (B)   |
|             | <b>Level</b>    | ADVANCED   |   |
|             | <b>Address</b>  | 957  |   |
|             | <b>Function</b> | This parameter determines the logic function applied to the result of the tests allowing calculating the output value. |   |

**P357a MPL1: Selecting Variable C**

|              |                 |   |              |
|--------------|-----------------|---|--------------|
| <b>P357a</b> | <b>Range</b>    | 0 ÷ 59  | See Table 47 |
|              | <b>Default</b>  | 0   | D0: Disable  |
|              | <b>Level</b>    | ADVANCED  |              |
|              | <b>Address</b>  | 932   |              |
|              | <b>Function</b> | This parameter selects the digital signal used to calculate the value of <b>MPL1</b> digital output.<br>The digital signals that can be selected are given in Table 47. |              |

**P357b MPL1: Function Applied to the Result of f(A,B) C**

|              |                 |  |  |
|--------------|-----------------|--|--|
| <b>P357b</b> | <b>Range</b>    | 0 ÷ 12   | 0: f(A,B) OR (C)<br>1: f(A,B) SET (C) RESET RISING EDGE<br>2: f(A,B) AND (C)<br>3: f(A,B) XOR (C)<br>4: f(A,B) NOR (C)<br>5: f(A,B) NAND (C)<br>6: f(A,B)\ OR (C)<br>7: f(A,B) OR (C\<br>8: f(A,B)\ AND (C)<br>9: f(A,B) AND (C\<br>10: f(A,B) RESET (C) SET RISING EDGE<br>11: f(A,B) SET (C) RESET FALLING EDGE<br>12: f(A,B) RESET (C) SET FALLING EDGE |
|              | <b>Default</b>  | 0  | 0: f(A,B) OR (C)   |
|              | <b>Level</b>    | ADVANCED   |  |
|              | <b>Address</b>  | 933  |  |
|              | <b>Function</b> | This parameter determines the logic function applied to the result of the two tests allowing calculating the output value. |  |

**P358 MPL1: Output Logic Level**

|             |                 |  |                     |
|-------------|-----------------|--|---------------------|
| <b>P358</b> | <b>Range</b>    | 0–1  | 0: FALSE<br>1: TRUE |
|             | <b>Default</b>  | 1  | 1: TRUE             |
|             | <b>Level</b>    | ADVANCED   |                     |
|             | <b>Address</b>  | 958  |                     |
|             | <b>Function</b> | MPL1 digital output logic function to apply a logic reversal (negation) to the calculated output signal: (0) FALSE = a logic negation is applied; (1) TRUE = no negation is applied. |                     |

**P359 MPL2: Digital Output Mode**

|             |                 |  |   |
|-------------|-----------------|--|---|
| <b>P359</b> | <b>Range</b>    | 0 ÷ 8  | 0: DISABLE<br>1: DIGITAL<br>2: DOUBLE DIGITAL<br>3: ANALOG<br>4: DOUBLE ANALOG<br>5: DOUBLE FULL<br>6: BRAKE<br>7: ABS BRAKE<br>8: ABS LIFT |
|             | <b>Default</b>  | 1  | 0: DISABLE  |
|             | <b>Level</b>    | ADVANCED   |   |
|             | <b>Address</b>  | 959  |   |
|             | <b>Function</b> | This parameter defines the operating mode of <b>virtual digital output 2</b> . The different operating modes are described at the beginning of this chapter. |   |

**P360 MPL2: Selecting Variable A**

|             |                 |  |                |
|-------------|-----------------|--|----------------|
| <b>P360</b> | <b>Range</b>    | 0 ÷ 119  | See Table 47   |
|             | <b>Default</b>  | 33   | D33: Fan Fault |
|             | <b>Level</b>    | ADVANCED   |                |
|             | <b>Address</b>  | 960  |                |
|             | <b>Function</b> | This parameter selects the digital signal used to calculate the value of <b>MPL2</b> digital output.<br>It selects an analog variable used to calculate the value of <b>MPL2</b> digital input if one of the “analog” operating modes is selected.<br>Digital signals and analog variables are detailed in Table 47. |                |

**P361 MPL2: Selecting Variable B**

|             |                 |   |              |
|-------------|-----------------|---|--------------|
| <b>P361</b> | <b>Range</b>    | 0 ÷ 119   | See Table 47 |
|             | <b>Default</b>  | 0   | D0: Disable  |
|             | <b>Level</b>    | ADVANCED  |              |
|             | <b>Address</b>  | 961   |              |
|             | <b>Function</b> | This parameter selects the second digital signal used to calculate the value of <b>MPL2</b> digital output.<br>It selects an analog variable used to calculate the value of <b>MPL2</b> digital input if one of the “analog” operating modes is selected.<br>Digital signals and analog variables are detailed in Table 47. |              |

**P362 MPL2: Testing Variable A**

|             |                 |  |  |
|-------------|-----------------|--|--|
| <b>P362</b> | <b>Range</b>    | 0 ÷ 7  | 0: ><br>1: ≥<br>2: <<br>3: ≤<br>4: ABS(x) ><br>5: ABS(x) ≥<br>6: ABS(x) <<br>7: ABS(x) ≤ |
|             | <b>Default</b>  | 0  | 0: >   |
|             | <b>Level</b>    | ADVANCED   |  |
|             | <b>Address</b>  | 362  |  |
|             | <b>Function</b> | This parameter defines the test to be performed for the variable detected by <b>P360</b> using <b>P364</b> as a comparing value. |  |

**P363 MPL2: Testing Variable B**

|             |                 |  |  |
|-------------|-----------------|--|--|
| <b>P363</b> | <b>Range</b>    | 0 ÷ 7  | 0: ><br>1: ≥<br>2: <<br>3: ≤<br>4: ABS(x) ><br>5: ABS(x) ≥<br>6: ABS(x) <<br>7: ABS(x) ≤ |
|             | <b>Default</b>  | 0  | 0: >   |
|             | <b>Level</b>    | ADVANCED   |  |
|             | <b>Address</b>  | 963  |  |
|             | <b>Function</b> | This parameter defines the test to be performed for the variable detected by <b>P361</b> using <b>P365</b> as a comparing value. |  |

**P364 MPL2: Comparing Value for Test A**

|             |                 |   |  |
|-------------|-----------------|---|--|
| <b>P364</b> | <b>Range</b>    | -32000 ÷ 32000  | -320.00 % ÷ 320.00 %<br>% of the full-scale value of selected variable A, see Table 47 |
|             | <b>Default</b>  | 0   | 0  |
|             | <b>Level</b>    | ADVANCED  |  |
|             | <b>Address</b>  | 964   |  |
|             | <b>Function</b> | This parameter defines the comparing value with the selected variable for test A. |  |

**P365 MPL2: Comparing Value for Test B**

|             |                 |   |  |
|-------------|-----------------|---|--|
| <b>P365</b> | <b>Range</b>    | -32000 ÷ 32000  | -320.00 % ÷ 320.00 %<br>% of the full-scale value of selected variable B, see Table 47 |
|             | <b>Default</b>  | 0   | 0  |
|             | <b>Level</b>    | ADVANCED  |  |
|             | <b>Address</b>  | 965   |  |
|             | <b>Function</b> | This parameter defines the comparing value with the selected variable for test B. |  |

**P366 MPL2: Function Applied to the Result of the 2 Tests**

|             |                 |  |   |
|-------------|-----------------|--|---|
| <b>P366</b> | <b>Range</b>    | 0 ÷ 12   | 0: (A) OR (B)<br>1: (A) SET (B) RESET<br>2: (A) AND (B)<br>3: (A) XOR (B)<br>4: (A) NOR (B)<br>5: (A) NAND (B)<br>6: (A\ ) OR (B)<br>7: (A) OR (B\<br>8: (A\ ) AND (B)<br>9: (A) AND (B\<br>10: (A) RESET (B) SET RISING EDGE<br>11: (A) SET (B) RESET FALLING EDGE<br>12: (A) RESET (B) SET FALLING EDGE |
|             | <b>Default</b>  | 1  | 1: (A) SET (B) RESET  |
|             | <b>Level</b>    | ADVANCED   |   |
|             | <b>Address</b>  | 966  |   |
|             | <b>Function</b> | This parameter determines the logic function applied to the result of the two tests allowing calculating the output value. |   |

**P366a MPL2: Selecting Variable C**

|              |                 |   |              |
|--------------|-----------------|---|--------------|
| <b>P366a</b> | <b>Range</b>    | 0 ÷ 59  | See Table 47 |
|              | <b>Default</b>  | 0   | D0: Disable  |
|              | <b>Level</b>    | ADVANCED  |              |
|              | <b>Address</b>  | 934   |              |
|              | <b>Function</b> | This parameter selects the digital signal used to calculate the value of <b>MPL2</b> digital output.<br>The digital signals that can be selected are given in Table 47. |              |

**P366b MPL2: Function Applied to the Result of f(A,B) C**

|              |                 |  |   |
|--------------|-----------------|--|---|
| <b>P366b</b> | <b>Range</b>    | 0 ÷ 12   | 0: f(A,B) OR (C)<br>1: f(A,B) SET (C) RESET RISING EDGE<br>2: f(A,B) AND (C)<br>3: f(A,B) XOR (C)<br>4: f(A,B) NOR (C)<br>5: f(A,B) NAND (C)<br>6: (A\ ) OR (B)<br>7: (A) OR (B\<br>8: (A\ ) AND (B)<br>9: (A) AND (B\<br>10: (A) RESET (B) SET RISING EDGE<br>11: (A) SET (B) RESET FALLING EDGE<br>12: (A) RESET (B) SET FALLING EDGE |
|              | <b>Default</b>  | 0  | 0: f(A,B) OR (C)  |
|              | <b>Level</b>    | ADVANCED   |   |
|              | <b>Address</b>  | 935  |   |
|              | <b>Function</b> | This parameter determines the logic function applied to the result of the two tests allowing calculating the output value. |   |

**P367 MPL2: Output Logic Level**

|             |                 |  |                     |
|-------------|-----------------|--|---------------------|
| <b>P367</b> | <b>Range</b>    | 0–1  | 0: FALSE<br>1: TRUE |
|             | <b>Default</b>  | 1  | 1: TRUE             |
|             | <b>Level</b>    | ADVANCED   |                     |
|             | <b>Address</b>  | 967  |                     |
|             | <b>Function</b> | MPL2 digital output logic function to apply a logic reversal (negation) to the calculated output signal: (0) FALSE = a logic negation is applied; (1) TRUE = no negation is applied. |                     |

**P368 MPL3: Digital Output Mode**

|             |                 |  |   |
|-------------|-----------------|--|---|
| <b>P368</b> | <b>Range</b>    | 0 ÷ 8  | 0: DISABLE<br>1: DIGITAL<br>2: DOUBLE DIGITAL<br>3: ANALOG<br>4: DOUBLE ANALOG<br>5: DOUBLE FULL<br>6: BRAKE<br>7: ABS BRAKE<br>8: ABS LIFT |
|             | <b>Default</b>  | 1  | 0: DISABLE  |
|             | <b>Level</b>    | ADVANCED   |   |
|             | <b>Address</b>  | 968  |   |
|             | <b>Function</b> | This parameter defines the operating mode of <b>virtual digital output 3</b> . The different operating modes are described at the beginning of this chapter. |   |

**P369 MPL3: Selecting Variable A**

|             |                 |  |                |
|-------------|-----------------|--|----------------|
| <b>P369</b> | <b>Range</b>    | 0 ÷ 119  | See Table 47   |
|             | <b>Default</b>  | 38   | D38: Fire Mode |
|             | <b>Level</b>    | ADVANCED   |                |
|             | <b>Address</b>  | 969  |                |
|             | <b>Function</b> | This parameter selects the digital signal used to calculate the value of <b>MPL3</b> digital output.<br>It selects an analog variable used to calculate the value of <b>MPL3</b> digital input if one of the “analog” operating modes is selected.<br>Digital signals and analog variables are detailed in Table 47. |                |

**P370 MPL3: Selecting Variable B**

|             |                 |   |              |
|-------------|-----------------|---|--------------|
| <b>P370</b> | <b>Range</b>    | 0 ÷ 119   | See Table 47 |
|             | <b>Default</b>  | 0   | D0: Disable  |
|             | <b>Level</b>    | ADVANCED  |              |
|             | <b>Address</b>  | 970   |              |
|             | <b>Function</b> | This parameter selects the second digital signal used to calculate the value of <b>MPL3</b> digital output.<br>It selects an analog variable used to calculate the value of digital input <b>MPL3</b> if one of the “analog” operating modes is selected.<br>Digital signals and analog variables are detailed in Table 47. |              |

**P371 MPL3: Testing Variable A**

|             |                 |  |  |
|-------------|-----------------|--|--|
| <b>P371</b> | <b>Range</b>    | 0 ÷ 7  | 0: ><br>1: ≥<br>2: <<br>3: ≤<br>4: ABS(x) ><br>5: ABS(x) ≥<br>6: ABS(x) <<br>7: ABS(x) ≤ |
|             | <b>Default</b>  | 0  | 0: >   |
|             | <b>Level</b>    | ADVANCED   |  |
|             | <b>Address</b>  | 971  |  |
|             | <b>Function</b> | This parameter defines the test to be performed for the variable detected by <b>P369</b> using <b>P373</b> as a comparing value. |  |

**P372 MPL3: Testing Variable B**

|             |                 |  |  |
|-------------|-----------------|--|--|
| <b>P372</b> | <b>Range</b>    | 0 ÷ 7  | 0: ><br>1: ≥<br>2: <<br>3: ≤<br>4: ABS(x) ><br>5: ABS(x) ≥<br>6: ABS(x) <<br>7: ABS(x) ≤ |
|             | <b>Default</b>  | 0  | 0: >   |
|             | <b>Level</b>    | ADVANCED   |  |
|             | <b>Address</b>  | 972  |  |
|             | <b>Function</b> | This parameter defines the test to be performed for the variable detected by <b>P370</b> using <b>P374</b> as a comparing value. |  |

**P373 MPL3: Comparing Value for Test A**

|             |                 |   |  |
|-------------|-----------------|---|--|
| <b>P293</b> | <b>Range</b>    | -32000 ÷ 32000  | -320.00 % ÷ 320.00 %<br>% of the full-scale value of selected variable A, see Table 47 |
|             | <b>Default</b>  | 0   | 0  |
|             | <b>Level</b>    | ADVANCED  |  |
|             | <b>Address</b>  | 973   |  |
|             | <b>Function</b> | This parameter defines the comparing value with the variable selected for test A. |  |

**P374 MPL3: Comparing Value for Test B**

|             |                 |   |  |
|-------------|-----------------|---|--|
| <b>P374</b> | <b>Range</b>    | -32000 ÷ 32000  | -320.00 % ÷ 320.00 %<br>% of the full-scale value of selected variable B, see Table 47 |
|             | <b>Default</b>  | 0   | 0  |
|             | <b>Level</b>    | ADVANCED  |  |
|             | <b>Address</b>  | 974   |  |
|             | <b>Function</b> | This parameter defines the comparing value with the variable selected for test B. |  |

**P375 MPL3: Function Applied to the Result of the 2 Tests**

|             |                 |  |   |
|-------------|-----------------|--|---|
| <b>P375</b> | <b>Range</b>    | 0 ÷ 12   | 0: (A) OR (B)<br>1: (A) SET (B) RESET<br>2: (A) AND (B)<br>3: (A) XOR (B)<br>4: (A) NOR (B)<br>5: (A) NAND (B)<br>6: (A\ OR (B)<br>7: (A) OR (B\<br>8: (A\ AND (B)<br>9: (A) AND (B\<br>10: (A) RESET (B) SET RISING EDGE<br>11: (A) SET (B) RESET FALLING EDGE<br>12: (A) RESET (B) SET FALLING EDGE |
|             | <b>Default</b>  | 0  | 0: (A) OR (B)   |
|             | <b>Level</b>    | ADVANCED   |   |
|             | <b>Address</b>  | 975  |   |
|             | <b>Function</b> | This parameter determines the logic function applied to the result of the two tests allowing calculating the output value. |   |

**P375a MPL3: Selecting Variable C**

|              |                 |   |              |
|--------------|-----------------|---|--------------|
| <b>P375a</b> | <b>Range</b>    | 0 ÷ 59  | See Table 47 |
|              | <b>Default</b>  | 0   | D0: Disable  |
|              | <b>Level</b>    | ADVANCED  |              |
|              | <b>Address</b>  | 936   |              |
|              | <b>Function</b> | This parameter selects the digital signal used to calculate the value of <b>MPL3</b> digital output.<br>The digital signals that can be selected are given in see Table 47. |              |

**P375b MPL3: Function Applied to the Result of f(A,B) C**

|              |                 |  |  |
|--------------|-----------------|--|--|
| <b>P375b</b> | <b>Range</b>    | 0 ÷ 12   | 0: f(A,B) OR (C)<br>1: f(A,B) SET (C) RESET RISING EDGE<br>2: f(A,B) AND (C)<br>3: f(A,B) XOR (C)<br>4: f(A,B) NOR (C)<br>5: f(A,B) NAND (C)<br>6: f(A,B)\ OR (C)<br>7: f(A,B) OR (C\<br>8: f(A,B)\ AND (C)<br>9: f(A,B) AND (C\<br>10: f(A,B) RESET (C) SET RISING EDGE<br>11: f(A,B) SET (C) RESET FALLING EDGE<br>12: f(A,B) RESET (C) SET FALLING EDGE |
|              | <b>Default</b>  | 0  | 0: f(A,B) OR (C)   |
|              | <b>Level</b>    | ADVANCED   |  |
|              | <b>Address</b>  | 937  |  |
|              | <b>Function</b> | This parameter determines the logic function applied to the result of the two tests allowing calculating the output value. |  |

**P376 MPL3: Output Logic Level**

|             |                 |  |                     |
|-------------|-----------------|--|---------------------|
| <b>P376</b> | <b>Range</b>    | 0–1  | 0: TRUE<br>1: FALSE |
|             | <b>Default</b>  | 1  | 1: TRUE             |
|             | <b>Level</b>    | ADVANCED   |                     |
|             | <b>Address</b>  | 976  |                     |
|             | <b>Function</b> | MPL3 digital output logic function to apply a logic reversal (negation) to the calculated output signal: (0) FALSE = a logic negation is applied; (1) TRUE = no negation is applied. |                     |

**P377 MPL4: Digital Output Mode**

|             |                 |  |   |
|-------------|-----------------|--|---|
| <b>P377</b> | <b>Range</b>    | 0 ÷ 8  | 0: DISABLE<br>1: DIGITAL<br>2: DOUBLE DIGITAL<br>3: ANALOG<br>4: DOUBLE ANALOG<br>5: DOUBLE FULL<br>6: BRAKE<br>7: ABS BRAKE<br>8: ABS LIFT |
|             | <b>Default</b>  | 1  | 0: DISABLE  |
|             | <b>Level</b>    | ADVANCED   |   |
|             | <b>Address</b>  | 977  |   |
|             | <b>Function</b> | This parameter defines the operating mode of <b>virtual digital output 4</b> . The different operating modes are described at the beginning of this chapter. |   |

**P378 MPL4: Selecting Variable A**

|             |                 |  |              |
|-------------|-----------------|--|--------------|
| <b>P378</b> | <b>Range</b>    | 0 ÷ 119  | See Table 47 |
|             | <b>Default</b>  | 0  | D0: Disable  |
|             | <b>Level</b>    | ADVANCED   |              |
|             | <b>Address</b>  | 978  |              |
|             | <b>Function</b> | This parameter selects the digital signal used to calculate the value of <b>MPL4</b> digital output.<br>It selects an analog variable used to calculate the value of <b>MPL4</b> digital input if one of the “analog” operating modes is selected.<br>Digital signals and analog variables are detailed in Table 47. |              |

**P379 MPL4: Selecting Variable B**

|             |                 |   |              |
|-------------|-----------------|---|--------------|
| <b>P379</b> | <b>Range</b>    | 0 ÷ 119   | See Table 47 |
|             | <b>Default</b>  | 0   | D0: Disable  |
|             | <b>Level</b>    | ADVANCED  |              |
|             | <b>Address</b>  | 979   |              |
|             | <b>Function</b> | This parameter selects the second digital signal used to calculate the value of <b>MPL4</b> digital output.<br>It selects an analog variable used to calculate the value of <b>MPL4</b> digital input if one of the “analog” operating modes is selected.<br>Digital signals and analog variables are detailed in Table 47. |              |

**P380 MPL4: Testing Variable A**

|             |                 |  |  |
|-------------|-----------------|--|--|
| <b>P380</b> | <b>Range</b>    | 0 ÷ 7  | 0: ><br>1: ≥<br>2: <<br>3: ≤<br>4: ABS(x) ><br>5: ABS(x) ≥<br>6: ABS(x) <<br>7: ABS(x) ≤ |
|             | <b>Default</b>  | 0  | 0: >   |
|             | <b>Level</b>    | ADVANCED   |  |
|             | <b>Address</b>  | 980  |  |
|             | <b>Function</b> | This parameter defines the test to be performed for the variable detected by <b>P378</b> using <b>P382</b> as a comparing value. |  |

**P381 MPL4: Testing Variable B**

|             |                 |  |  |
|-------------|-----------------|--|--|
| <b>P381</b> | <b>Range</b>    | 0 ÷ 7  | 0: ><br>1: ≥<br>2: <<br>3: ≤<br>4: ABS(x) ><br>5: ABS(x) ≥<br>6: ABS(x) <<br>7: ABS(x) ≤ |
|             | <b>Default</b>  | 0  | 0: >   |
|             | <b>Level</b>    | ADVANCED   |  |
|             | <b>Address</b>  | 981  |  |
|             | <b>Function</b> | This parameter defines the test to be performed for the variable detected by <b>P379</b> using <b>P383</b> as a comparing value. |  |

**P382 MPL4: Comparing Value for Test A**

|             |                 |   |  |
|-------------|-----------------|---|--|
| <b>P382</b> | <b>Range</b>    | -32000 ÷ 32000  | -320.00 % ÷ 320.00 %<br>% of the full-scale value of selected variable A, see Table 47 |
|             | <b>Default</b>  | 0   | 0  |
|             | <b>Level</b>    | ADVANCED  |  |
|             | <b>Address</b>  | 982   |  |
|             | <b>Function</b> | This parameter defines the comparing value with the selected variable for test A. |  |

**P383 MPL4: Comparing Value for Test B**

|             |                 |   |  |
|-------------|-----------------|---|--|
| <b>P383</b> | <b>Range</b>    | -32000 ÷ 32000  | -320.00 % ÷ 320.00 %<br>% of the full-scale value of selected variable B, see Table 47 |
|             | <b>Default</b>  | 0   | 0  |
|             | <b>Level</b>    | ADVANCED  |  |
|             | <b>Address</b>  | 983   |  |
|             | <b>Function</b> | This parameter defines the comparing value with the selected variable for test B. |  |

**P384 MPL4: Function Applied to the Result of the 2 Tests**

|             |                 |  |   |
|-------------|-----------------|--|---|
| <b>P384</b> | <b>Range</b>    | 0 ÷ 12   | 0: (A) OR (B)<br>1: (A) SET (B) RESET<br>2: (A) AND (B)<br>3: (A) XOR (B)<br>4: (A) NOR (B)<br>5: (A) NAND (B)<br>6: (A\ OR (B)<br>7: (A) OR (B\<br>8: (A\ AND (B)<br>9: (A) AND (B\<br>10: (A) RESET (B) SET RISING EDGE<br>11: (A) SET (B) RESET FALLING EDGE<br>12: (A) RESET (B) SET FALLING EDGE |
|             | <b>Default</b>  | 0  | 0: (A) OR (B)   |
|             | <b>Level</b>    | ADVANCED   |   |
|             | <b>Address</b>  | 984  |   |
|             | <b>Function</b> | This parameter determines the logic function applied to the result of the two tests allowing calculating the output value. |   |

**P384a MPL4: Selecting Variable C**

|              |                 |   |              |
|--------------|-----------------|---|--------------|
| <b>P384a</b> | <b>Range</b>    | 0 ÷ 59  | See Table 47 |
|              | <b>Default</b>  | 0   | D0: Disable  |
|              | <b>Level</b>    | ADVANCED  |              |
|              | <b>Address</b>  | 938   |              |
|              | <b>Function</b> | This parameter selects the digital signal used to calculate the value of <b>MPL4</b> digital output.<br>The digital signals that can be selected are given in Table 47. |              |

**P384b MPL4: Function Applied to the Result of f(A,B) C**

|              |                 |  |  |
|--------------|-----------------|--|--|
| <b>P384b</b> | <b>Range</b>    | 0 ÷ 12   | 0: f(A,B) OR (C)<br>1: f(A,B) SET (C) RESET RISING EDGE<br>2: f(A,B) AND (C)<br>3: f(A,B) XOR (C)<br>4: f(A,B) NOR (C)<br>5: f(A,B) NAND (C)<br>6: f(A,B)\ OR (C)<br>7: f(A,B) OR (C\<br>8: f(A,B)\ AND (C)<br>9: f(A,B) AND (C\<br>10: f(A,B) RESET (C) SET RISING EDGE<br>11: f(A,B) SET (C) RESET FALLING EDGE<br>12: f(A,B) RESET (C) SET FALLING EDGE |
|              | <b>Default</b>  | 0  | 0: f(A,B) OR (C)   |
|              | <b>Level</b>    | ADVANCED   |  |
|              | <b>Address</b>  | 939  |  |
|              | <b>Function</b> | This parameter determines the logic function applied to the result of the two tests allowing calculating the output value. |  |

**P385 MPL4: Output Logic Level**

|             |                 |  |                     |
|-------------|-----------------|--|---------------------|
| <b>P385</b> | <b>Range</b>    | 0–1  | 0: TRUE<br>1: FALSE |
|             | <b>Default</b>  | 1  | 1: TRUE             |
|             | <b>Level</b>    | ADVANCED   |                     |
|             | <b>Address</b>  | 985  |                     |
|             | <b>Function</b> | MPL4 digital output logic function to apply a logic reversal (negation) to the calculated output signal: (0) FALSE = a logic negation is applied; (1) TRUE = no negation is applied. |                     |



**NOTE**

Although it is possible to program a digital output so that it reflects the drive status, this indication is not be considered “SIL rated” as per the safety standards the STO function relates to. The STO safety function is accomplished with a dedicated and redundant hardware circuit, assessed and certified with defined SIL and PL levels, whereas the control software and the outputs implementing hardware do not meet the requirements above.

For that reason, the output signals within safety functions of the system where the drive is installed must not be used.

For details on the STO function, consult the Safe Torque Off Function - Application Manual.

## 31. INPUTS FOR REFERENCES FROM OPTIONAL BOARD

This menu relates to ES847 I/O expansion board. It can be viewed only if **R023** (I/O board setting) = XAIN (see the EXPANSION BOARD CONFIGURATION MENU).

In addition to the analog inputs located on the control board, a current analog input and a voltage analog input can be acquired if ES847 is fitted.

### 31.1. Scaling Analog Inputs XAIN4, XAIN5



**NOTE** Please refer to the Sinus Penta's Installation Guide for hardware details about analog inputs.

Two analog inputs (XAIN4, XAIN5) are located on ES847 control board.

XAIN4 is a current input and XAIN5 is a voltage input. They are both bipolar analog inputs ( $-10V \div +10V$  or  $-20mA \div +20mA$ ).

For both analog inputs, parameters **P390** to **P399** allow setting the type of signal to be acquired, offset compensation (if any), scaling to obtain a speed reference or a torque reference, the signal filtering time constant.

Parameter **P393** sets the offset of the input analog signal (if **P393**=0 offset is zero), while parameter **P394** defines the filtering time constant (factory setting: **P394** = 100ms).

The voltage signal can be bipolar ( $-10V \div +10V$ ) or unipolar ( $0V \div +10V$ ).

The current signal can be bipolar ( $-20mA \div +20mA$ ), unipolar ( $0mA \div +20mA$ ) or can have a minimum offset ( $4mA \div 20mA$ ).

The user will set each analog input mode in parameters **P390**, **P395**.

Table 65: Analog input hardware mode

| Type / Terminals               | Name  | Type             | Parameter   |
|--------------------------------|-------|------------------|-------------|
| Differential input / Pin 11,12 | XAIN4 | $\pm 10V$ Input  | <b>P390</b> |
| Differential input / Pin 13,14 | XAIN5 | $\pm 20mA$ Input | <b>P395</b> |



**NOTE** Configurations different from the ones stated in the table above are not allowed.

Scaling is obtained by setting the parameters relating to the **linear function for the conversion** from the value read by the analog input to the corresponding speed/torque reference value.

The **conversion function** is a **straight line** passing through **2 points** in **Cartesian coordinates** having the values read by the analog input in the X-axis, and the speed/torque reference values in the Y-axis. The speed/torque reference values are multiplied by the reference percent parameters.

**Each point** is detected through its **two coordinates**.

The ordinates of the two points are the following:

the value of **Speed\_Min** (or **Trq\_Min** for the torque reference) multiplied by the percentage set with **P391a/P396a** for the **first point**; the value of **Speed\_Max** (or **Trq\_Max** for the torque reference) multiplied by the percentage set with **P392a/P397a** for the **second point**.

**Speed\_Min** depends on the selected motor: see parameter **C028** (motor 1), **C071** (motor 2), or **C114** (motor 3).

**Trq\_Min** depends on the selected motor: see parameter **C047** (motor 1), **C090** (motor 2) or **C133** (motor 3).

**Speed\_Max** depends on the selected motor: see parameter **C029** (motor 1), **C072** (motor 2) or **C115** (motor 3).

**Trq\_Max** depends on the selected motor: see parameter **C048** (motor 1), **C091** (motor 2), or **C134** (motor 3).

The X-axis values of the two points depend on the analog input:

**XAIN4** Input:

Parameter **P391** is the X-axis of the **first point**; parameter **P392** is the X-axis of the **second point**.

**XAIN5** Input:

250/472

Parameter **P396** is the X-axis of the **first point**; parameter **P397** is the X-axis of the **second point**.

(see also Scaling Analog Inputs REF, AIN1, AIN2).

## 31.2. List of parameters P390 to P399

Table 66: List of parameters P390 to P399

| Parameter    | FUNCTION  | User Level | DEFAULT VALUE | MODBUS Address |
|--------------|---|------------|---------------|----------------|
| <b>P390</b>  | Type of signal over <b>XAIN4</b> input  | ADVANCED   | 1:0÷10V       | 990            |
| <b>P391</b>  | Value of <b>XAIN4</b> input producing min. reference (X-axis)                             | ADVANCED   | 0.0V          | 991            |
| <b>P391a</b> | Percentage of Speed_Min/Trq_Min producing min. reference (Y-axis related to <b>P391</b> ) | ADVANCED   | 100.0%        | 704            |
| <b>P392</b>  | Value of <b>XAIN4</b> input producing max. reference (X-axis)                             | ADVANCED   | 10.0V         | 992            |
| <b>P392a</b> | Percentage of Speed_Max/Trq_Max producing max. reference (Y-axis related to <b>P392</b> ) | ADVANCED   | 100.0%        | 710            |
| <b>P393</b>  | Offset over <b>XAIN4</b> input  | ADVANCED   | 0V            | 993            |
| <b>P394</b>  | Filtering time over <b>XAIN4</b> input  | ADVANCED   | 100ms         | 994            |
| <b>P395</b>  | Type of signal over <b>XAIN5</b> input  | ADVANCED   | 3: 4÷20mA     | 995            |
| <b>P396</b>  | Value of <b>XAIN5</b> input producing min. reference (X-axis)                             | ADVANCED   | 4.0mA         | 996            |
| <b>P396a</b> | Percentage of Speed_Min/Trq_Min producing min. reference (Y-axis related to <b>P396</b> ) | ADVANCED   | 100.0%        | 711            |
| <b>P397</b>  | Value of <b>XAIN5</b> input producing max. reference (X-axis)                             | ADVANCED   | 20.0mA        | 997            |
| <b>P397a</b> | Percentage of Speed_Min/Trq_Min producing min. reference (Y-axis related to <b>P397</b> ) | ADVANCED   | 100.0%        | 712            |
| <b>P398</b>  | Offset over <b>XAIN5</b> input  | ADVANCED   | 0mA           | 998            |
| <b>P399</b>  | Filtering time over <b>XAIN5</b> input  | ADVANCED   | 100 ms        | 999            |

### P390 Type of Signal over XAIN4 Input

| P390 | Range    | 0 ÷ 1   | 0: ± 10 V<br>1: 0 ÷ 10 V |
|------|----------|---|--------------------------|
|      | Default  | 1   | 1:0÷10V                  |
|      | Level    | ADVANCED  |                          |
|      | Address  | 990   |                          |
|      | Function | <p>This parameter selects the type of single-ended, analog signal over XAIN4 terminal in the terminal board. The signal can be a voltage signal, a unipolar signal, or a bipolar signal.</p> <p><b>0:</b> ± 10 V Bipolar voltage input between -10V and +10V. The detected signal is saturated between these two values.</p> <p><b>1:</b> 0 ÷ 10 V Unipolar voltage input between 0V and +10V. The detected signal is saturated between these two values.</p> |                          |

**P391 Value of XAIN4 Input Producing Min. Reference**

|             |                 |  |   |
|-------------|-----------------|--|---|
| <b>P391</b> | <b>Range</b>    | -100 ÷ 100, if <b>P390</b> = 0<br>0 ÷ 100, if <b>P390</b> = 1  | -10.0 V ÷ 10.0 V, if <b>P390</b> = 0: ± 10 V<br>0.0 V ÷ 10.0V, if <b>P390</b> = 1: 0 ÷ 10 V |
|             | <b>Default</b>  | 0  | 0.0V  |
|             | <b>Level</b>    | ADVANCED   |   |
|             | <b>Address</b>  | 991  |   |
|             | <b>Function</b> | This parameter selects the value for XAIN4 input signal for minimum reference, or better the reference set in <b>C028 xP391a</b> (Master mode) or in <b>C047xP391a</b> (Slave mode). If motor 2 is active, <b>C071</b> and <b>C090</b> will be used instead of <b>C028</b> and <b>C047</b> ; if motor 3 is active, the values set in <b>C114</b> and <b>C133</b> will be used. |   |

**P391a Percentage of Speed Min/Trq Min. Producing Min. Reference (Y-axis related to P391)**

|              |                 |  |        |
|--------------|-----------------|--|--------|
| <b>P391a</b> | <b>Range</b>    | 0 ÷ 1000   | 100.0% |
|              | <b>Default</b>  | 1000   | 100.0% |
|              | <b>Level</b>    | ADVANCED   |        |
|              | <b>Address</b>  | 704  |        |
|              | <b>Function</b> | This parameter represents the min. speed percentage (or the min. torque percentage for a torque reference) to be used for the minimum reference set with <b>P391</b> . |        |

**P392 Value of XAIN4 Input Producing Max. Reference (X-axis)**

|             |                 |   |   |
|-------------|-----------------|---|---|
| <b>P392</b> | <b>Range</b>    | -100 ÷ 100, if <b>P390</b> = 0<br>0 ÷ 100, if <b>P390</b> = 3   | -10.0 V ÷ 10.0 V, if <b>P390</b> = 0: ± 10 V<br>0.0 V ÷ 10.0V, if <b>P390</b> = 1: 0 ÷ 10 V |
|             | <b>Default</b>  | 100   | +10.0V  |
|             | <b>Level</b>    | ADVANCED  |   |
|             | <b>Address</b>  | 992   |   |
|             | <b>Function</b> | This parameter selects the value for XAIN4 input signal for maximum reference, or better the reference set in <b>C029xP392a</b> (Master mode) or in <b>C048xP392a</b> (Slave mode). If motor 2 is active, <b>C072</b> and <b>C091</b> will be used instead of <b>C029</b> and <b>C048</b> ; if motor 3 is active, the values set in <b>C115</b> and <b>C134</b> will be used. |   |

**P392a Percentage of Speed Max/Trq Max Producing Max. Reference (Y-axis related to P392)**

|              |                 |  |        |
|--------------|-----------------|--|--------|
| <b>P392a</b> | <b>Range</b>    | 0 ÷ 1000   | 100.0% |
|              | <b>Default</b>  | 1000   | 100.0% |
|              | <b>Level</b>    | ADVANCED   |        |
|              | <b>Address</b>  | 710  |        |
|              | <b>Function</b> | This parameter represents the max. speed percentage (or the max. torque percentage for a torque reference) to be used for the maximum reference set with <b>P392</b> . |        |

**P393 Offset over XAIN4 Input**

|             |                 |   |                     |
|-------------|-----------------|---|---------------------|
| <b>P393</b> | <b>Range</b>    | -1000 ÷ 1000  | -10.00 V ÷ +10.00 V |
|             | <b>Default</b>  | 0   | 0.00 V              |
|             | <b>Level</b>    | ADVANCED  |                     |
|             | <b>Address</b>  | 993   |                     |
|             | <b>Function</b> | This parameter selects the offset correction value of the XAIN4 analog signal that has been measured.<br>The value set is added to the signal measured before saturation or conversion; its unit of measure is the same as the one of the signal selected for XAIN4 analog input. |                     |

**P394 Filtering Time over XAIN4 Input**

|             |                 |  |              |
|-------------|-----------------|--|--------------|
| <b>P394</b> | <b>Range</b>    | 0 ÷ +65000   | 0 ÷ +65000ms |
|             | <b>Default</b>  | 100  | 100 ms       |
|             | <b>Level</b>    | ADVANCED   |              |
|             | <b>Address</b>  | 994  |              |
|             | <b>Function</b> | This parameter selects the value of the filter time constant of the first command applied to the XAIN4 input signal when the signal saturation and conversion is over. |              |

**P395 Type of Signal over XAIN5 Input**

|             |                 |   |  |
|-------------|-----------------|---|--|
| <b>P395</b> | <b>Range</b>    | 2 ÷ 4   | 2: ± 20 mA<br>3: 4 ÷ 20 mA<br>4: 0 ÷ 20 mA |
|             | <b>Default</b>  | 3   | 3: 4 ÷ 20 mA                               |
|             | <b>Level</b>    | ADVANCED  |  |
|             | <b>Address</b>  | 995   |  |
|             | <b>Function</b> | This parameter selects the type of differential analog signal over terminals <b>XAIN5+</b> and <b>XAIN5-</b> in the terminal board.<br>The signal can be a current signal, a unipolar signal, or a bipolar signal.<br><b>2:</b> ±20 mA Bipolar current input between -20mA and +20mA. The detected signal is saturated between these two values.<br><b>3:</b> 4 ÷ 20 mA Unipolar current input with min. threshold, between +4 mA and +20mA. The detected signal is saturated between these two values.<br>Before being saturated, if the detected signal is lower than 4 mA or greater than 20 mA, alarms <b>A069</b> or <b>A086</b> trip.<br><b>4:</b> 0 ÷ 20 mA Unipolar current input between +0 mA and +20mA. The detected signal is saturated between these two values. |  |

**P396 Value of XAIN5 Producing Min. Reference (X-axis)**

|             |                 |   |   |
|-------------|-----------------|---|---|
| <b>P396</b> | <b>Range</b>    | -200 ÷ 200, if <b>P395</b> = 2<br>+40 ÷ 200, if <b>P395</b> = 3<br>0 ÷ 200, if <b>P395</b> = 4  | -20.0 mA ÷ 20.0 mA, if <b>P395</b> = 2: ± 20 mA<br>+4.0mA ÷ 20.0 mA, if <b>P395</b> = 3: 4 ÷ 20 mA<br>0.0 mA ÷ 20.0 mA, if <b>P395</b> = 4: 0 ÷ 20 mA |
|             | <b>Default</b>  | 40  | +4.0mA  |
|             | <b>Level</b>    | ADVANCED  |   |
|             | <b>Address</b>  | 996   |   |
|             | <b>Function</b> | This parameter selects the value for XAIN5 input signal for minimum reference, or better the reference set in <b>C028xP396a</b> (Master mode) or in <b>C047xP396a</b> (Slave mode). If motor 2 is active, <b>C071</b> and <b>C090</b> will be used instead of <b>C028</b> and <b>C047</b> ; if motor 3 is active, the values set in <b>C114</b> and <b>C133</b> will be used. |   |

**P396a Percentage of Speed Min/Trq Min Producing Min. Reference (Y-axis related to P396)**

|              |                 |  |        |
|--------------|-----------------|--|--------|
| <b>P396a</b> | <b>Range</b>    | 0 ÷ 1000   | 100.0% |
|              | <b>Default</b>  | 1000   | 100.0% |
|              | <b>Level</b>    | ADVANCED   |        |
|              | <b>Address</b>  | 711  |        |
|              | <b>Function</b> | This parameter represents the min. speed percentage (or the min. torque percentage for a torque reference) to be used for the minimum reference set with <b>P396</b> . |        |

**P397 Value of XAIN5 Input Producing Max. Reference (X-axis)**

|             |                 |   |   |
|-------------|-----------------|---|---|
| <b>P397</b> | <b>Range</b>    | -200 ÷ 200, if <b>P395</b> = 2<br>+40 ÷ 200, if <b>P395</b> = 3<br>0 ÷ 200, if <b>P395</b> = 4  | -20.0 mA ÷ 20.0 mA, if <b>P395</b> = 2: ± 20 mA<br>+4.0mA ÷ 20.0 mA, if <b>P395</b> = 3: 4 ÷ 20 mA<br>0.0 mA ÷ 20.0 mA, if <b>P395</b> = 4: 0 ÷ 20 mA |
|             | <b>Default</b>  | 200   | +20.0mA   |
|             | <b>Level</b>    | ADVANCED  |   |
|             | <b>Address</b>  | 997   |   |
|             | <b>Function</b> | This parameter selects the value for XAIN5 input signal for maximum reference, or better the reference set in <b>C029xP397a</b> (Master mode) or in <b>C048xP397a</b> (Slave mode). If motor 2 is active, <b>C072</b> and <b>C091</b> will be used instead of <b>C029</b> and <b>C048</b> ; if motor 3 is active, the values set in <b>C115</b> and <b>C134</b> will be used. |   |

**P397a Percentage of Speed Max/Trq Max Producing Max. Reference (Y-axis related to P397)**

|              |                 |  |        |
|--------------|-----------------|--|--------|
| <b>P397a</b> | <b>Range</b>    | 0 ÷ 1000   | 100.0% |
|              | <b>Default</b>  | 1000   | 100.0% |
|              | <b>Level</b>    | ADVANCED   |        |
|              | <b>Address</b>  | 712  |        |
|              | <b>Function</b> | This parameter represents the max. speed percentage (or the max. torque percentage for a torque reference) to be used for the maximum reference set with <b>P397</b> . |        |

**P398 Offset over XAIN5 Input**

|             |                 |   |                        |
|-------------|-----------------|---|------------------------|
| <b>P398</b> | <b>Range</b>    | -2000 ÷ 2000  | - 20.00 mA ÷ +20.00 mA |
|             | <b>Default</b>  | 0   | 0 mA                   |
|             | <b>Level</b>    | ADVANCED  |                        |
|             | <b>Address</b>  | 998   |                        |
|             | <b>Function</b> | This parameter selects the offset correction value of XAIN5 analog signal that has been measured.<br>The value set is added to the signal measured before saturation or conversion; its unit of measure is the same as the one of the signal selected for XAIN5 analog input. |                        |

**P399 Filtering Time over XAIN5 Input**

|             |                 |  |              |
|-------------|-----------------|--|--------------|
| <b>P399</b> | <b>Range</b>    | 0 ÷ +65000   | 0 ÷ +65000ms |
|             | <b>Default</b>  | 100  | 100 ms       |
|             | <b>Level</b>    | ADVANCED   |              |
|             | <b>Address</b>  | 999  |              |
|             | <b>Function</b> | This parameter selects the value of the filter time constant of the first command applied to XAIN5 input signal when the signal saturation and conversion is over. |              |

## 32. AUTOTUNE MENU

### 32.1. Overview

---



**NOTE** See the FIRST STARTUP section for tuning based on the control algorithm to be used.



**NOTE** At the end of the Autotune procedure, the system automatically saves the whole parameter set of the drive.



**NOTE** Autotune must be performed only after entering the motor ratings or the ratings of the encoder used as a speed feedback. Please refer to the MOTOR CONFIGURATION MENU and the ENCODER/FREQUENCY INPUTS MENU.

The selected motor may be tuned in order to obtain the machine ratings or the parameterization required for the correct functioning of the control algorithms. The user can also check the proper operation/wiring of the encoder used as a speed feedback.

The Autotune menu includes two programming inputs, **I073** and **I074**. Input **I073** allows enabling and selecting the type of autotune. Input **I074**—which can be programmed only if **I073** = Motor Tune— describes the type of autotune which is performed. Because the values set in **I073** or **I074** cannot be changed once for all and are automatically reset after autotuning, the **ENABLE-A** **ENABLE-B** signals must be disabled and the **ESC** key must be used to accept the new value.

#### 32.1.1. MOTOR AUTOTUNE AND ADJUSTING LOOPS

Set **I073** as Motor Tune to enable autotune functions that can be selected with **I074**.



**NOTE** For the correct operation of the tuning algorithms, enter the motor ratings and the ratings of the encoder used as a speed feedback. Please refer to the MOTOR CONFIGURATION MENU and the ENCODER/FREQUENCY INPUTS MENU.

Table 67: Programmable “Motor Tune” functions

| I074 Setting                      | Motor Rotation | Type of Tune   |
|-----------------------------------|----------------|--|
| 0: all Ctrl no rotation           | No             | <b>Automatic</b> estimation of the stator resistance and the leakage inductance. If no-load current (C018) is zero, no-load current values are computed based on the rated power of the connected motor.<br>Tuning mode required for the correct operation of the control algorithms.  |
| 1: FOC (VTC) Auto no rotation     | No             | <b>Automatic</b> autotune of the current loop.<br>Tuning mode required for the correct operation of the FOC algorithm.<br>This tuning is required also for the VTC algorithm as a pre-tuning of the rotor time constant (2: FOC/VTC Auto + rotation).<br>If autotune of the current loop fails (Alarm <b>A065</b> Autotune KO trips), the current loop may be manually tuned - see 4: FOC Man no rotation (current). While autotuning, the system can monitor the reference current and the current obtained in analog outputs AO2 and AO1 respectively. |
| 2: VTC/FOC Auto + rotation        | Yes            | <b>Automatic</b> estimation of the rotor time constant.<br>Tuning mode required for the correct operation of the VTC and FOC algorithms.<br>Tuning mode required for the correct operation of FOC algorithm.<br>After entering the correct no-load current value (parameters <b>C021</b> , <b>C064</b> , <b>C107</b> for motors M1, M2 and M3 respectively) and tuning the current loop, the system can measure the rotor time constant for no-load rotation of the connected motor up to 90% of its constant speed.                                     |
| 3: VTC/FOC Man rotation (speed)   | Yes            | <b>Manual</b> tune of the speed loop.<br>Analog outputs AO1 and AO2 are displayed, showing the speed reference and the speed value obtained with the preset parameters of the speed regulator (see the SPEED LOOP AND CURRENT BALANCING MENU). Set the current regulator’s parameters in order to reduce to a minimum the difference between the two waveforms.  |
| 4: FOC Man no rotation (current)  | No             | <b>Manual</b> tune of the current loop.<br>If automatic tuning 1: FOC Auto no rotation fails, the current loop may be manually tuned. Display analog outputs AO1 and AO2, showing the current reference value and the current value measured. Set the current regulator’s parameters (see the FOC REGULATORS MENU) in order to reduce to a minimum the difference between the two waveforms.   |
| 5: FOC Man no rotation (flux)     | No             | <b>Manual</b> tune of the flux loop.<br>The correct parameters of the flux regulator are calculated whenever the rotor time constant value changes (see 2: FOC Auto rotation).<br>However, you can manually tune the flux loop.<br>Display analog outputs AO1 and AO2, showing the flux reference value and the flux value obtained. Set the current regulator’s parameters in order to reduce to a minimum the difference between the two waveforms.<br>See the FOC REGULATORS MENU.  |
| 6: VTC Auto no rotation (current) | No             | <b>Automatic tuning</b> of the current loop.<br>Only algebraic calculations are performed and parameters <b>P175r1</b> , <b>P175s1</b> , <b>P175t1</b> , <b>P175u1</b> , <b>P175v1</b> are saved.  |



**NOTE** If **Manual tune** is selected, do the following to quit the function: disable the **ENABLE-A** and **ENABLE-B** commands and set **I073** = [0: Disable].



**NOTE** After tuning the rotor time constant, whenever the time constant value is manually changed, parameters **P158** and **P159** are adjusted based on the time constant value that has been set up.

### 32.1.2. CHECKING THE ENCODER OPERATION

Set **I073** as Encoder Tune to check the correct operation of the incremental encoder selected as a speed feedback (see the ENCODER/FREQUENCY INPUTS MENU) and to automatically set the correct direction of rotation.

**NOTE**

Before checking the correct operation of the encoder used as a speed feedback, **enter the motor ratings and the encoder ratings.**

Please refer to the MOTOR CONFIGURATION MENU and the ENCODER/FREQUENCY INPUTS MENU.

Once **I073** is set as Encoder Tune and the **ENABLE-A** and **ENABLE-B** terminals have been closed, the connected motor attains a speed of rotation of approx. 150 rpm; its speed of rotation is detected by the encoder, then the drive is disabled. The following messages can be displayed on the display/keypad:

**A059 Encoder Fault**

**W31 Encoder OK**

Then the following message is always displayed:

**W32 OPEN ENABLE**

If alarm **A059 Encoder Fault** trips: in the encoder input, the value measured by the drive does not match with the real speed of rotation of the motor. Check that the encoder is properly set up (see the ENCODER/FREQUENCY INPUTS MENU) and wired; if the Encoder B input is used, check the Configuration of the dip-switches located on **ES836** or **ES913** optional board (see the Sinus Penta's Installation Guide).

If **W31 Encoder OK** appears: the speed feedback from encoder is correct.

In addition, the autotune sets the encoder signal as feedback with parameter **C199**.

## 32.2. List of Inputs I073 - I074

Table 68: List of inputs I073 - I074

| Input | FUNCTION           | User Level | MODBUS Address |
|-------|--------------------|------------|----------------|
| I073  | Type of autotune   | BASIC      | 1460           |
| I074  | Type of motor tune | BASIC      | 1461           |

### I073 Type of Autotune

|             |                 |  |  |
|-------------|-----------------|--|--|
| <b>I073</b> | <b>Range</b>    | 0 ÷ 2  | 0: Disable<br>1: Motor Tune<br>2: Encoder Tune |
|             | <b>Default</b>  | This is not a programming parameter: the input is set to zero whenever the drive is powered on and whenever the command is executed.   |  |
|             | <b>Level</b>    | BASIC  |  |
|             | <b>Address</b>  | 1460   |  |
|             | <b>Function</b> | <p>I073 selects the type of tune to perform.</p> <p>If you select [1: Motor Tune]: I074 sets different types of tune for current loops, flux loops and speed loops and for the estimation of the motor ratings (see Motor Autotune and Adjusting Loops).</p> <p>If you select [2: Encoder Tune]: you can check the correct operation of the encoder used as a speed feedback (see Checking the Encoder Operation).</p> |  |

### I074 Type of Motor Tune

|             |                 |  |   |
|-------------|-----------------|--|---|
| <b>I074</b> | <b>Range</b>    | 0 ÷ 6  | 0: All Auto no rotation<br>1: FOC (VTC) Auto no rotation<br>2: VTC/FOC Auto + rotation (tau)<br>3: VTC/FOC Man rotation (speed)<br>4: FOC Man no rotation (current)<br>5: FOC Man no rotation (flux)<br>6: VTC Auto no rotation (current) |
|             | <b>Default</b>  | This is not a programming parameter: the input is set to zero whenever the drive is powered on and whenever the command is executed. |   |
|             | <b>Level</b>    | BASIC  |   |
|             | <b>Address</b>  | 1461   |   |
|             | <b>Function</b> | I074 selects the type of autotune to perform if I073 = [1: Motor Tune] (see section Motor Autotune and Adjusting Loops).             |   |



**NOTE**

No changes can be made to I073 and I074 when the **ENABLE-A** and **ENABLE-B** signals are present. If you attempt to change these values when the **ENABLE-A** and **ENABLE-B** signals are present, “W34 ILLEGAL DATA” warning appears. Remove the **ENABLE-A** and **ENABLE-B** signals to change these values and activate them again to begin the selected autotune process.



**NOTE**

If **SAVE/ENTER** is pressed to store the changes made to I073 and I074, “W17 SAVE IMPOSSIBLE” warning appears. Use the **ESC** key instead.

### 33. CARRIER FREQUENCY MENU

#### 33.1. Overview

The Carrier Frequency Menu sets some of the PWM modulation characteristics based on the preset type of control.

##### 33.1.1. IFD CONTROL AND VTC CONTROL

The IFD and VTC control algorithms allow gaining access to all the parameters included in the Carrier Frequency menu. The user can set the minimum value and the maximum value of the switching carrier frequency and the number of pulses per period used to produce the output frequency when switching from min. carrier frequency to max. carrier frequency (synchronous modulation).

The silent modulation function can also be enabled (C004).

##### 33.1.2. EXAMPLE (IFD AND VTC)

Setting two levels of carrier frequency and the number of pulses used for synchronous modulation.

A lower value for carrier frequency ensures a better performance of the motor but implies higher noise levels. Suppose that the connected motor has a rated speed equal to 1500rpm at 50Hz and that you need the best performance up to 200rpm and a “noiseless” carrier frequency at max. speed (3000rpm).

In this case, the max. speed of the drive will produce an output voltage with a frequency value equal to 100Hz; in proximity to this speed the carrier frequency should be at its maximum level. Suppose that a model implementing max. 16kHz carrier frequency is used.

Assign the following:

C001 = 1600Hz

C002 = 16000Hz

C003 ≥ (C002/100Hz) = (160 pulses per period)

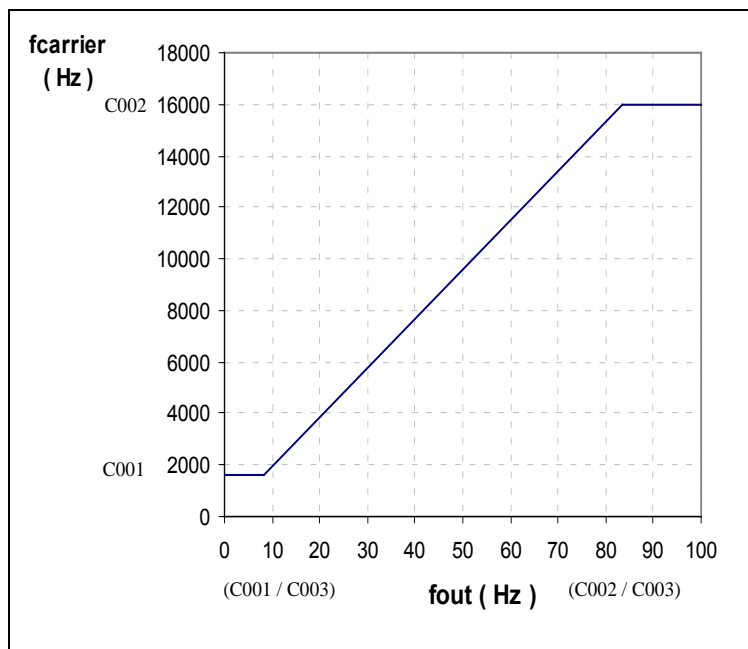

Figure 40: Carrier frequency (example)

Suppose that C003 = 192np, so that C002/C003 = 16000/192 = 83.33Hz. The max. carrier frequency is obtained with this output frequency. The min. frequency is kept constant until frequency C001/C003 = 8.33 Hz is attained, corresponding to 250 rpm of the motor speed. In the output frequency range, ranging from 8.33 to 83.33Hz, synchronous modulation is obtained and the carrier frequency applied results from: f carrier = fout \* C003 [Hz].

### 33.1.3. FOC CONTROL

The FOC control algorithm selects the silent modulation mode (**C004**) and allows increasing the carrier frequency with parameter **C002**. The FOC algorithm uses a carrier frequency corresponding to:

- max. carrier freq. allowed for the Penta size concerned if freq. is < 8kHz (see Table 79 and Table 83);
- the greatest between **C002** and 8 kHz if the max. carrier freq. allowed is > 8kHz; this means that the value set in **C002** is applied only when exceeding 8kHz.

The carrier frequency is not affected by the value set in **C001**.

### 33.1.4. ANY CONTROL ALGORITHM

The maximum preset carrier frequency value also limits the maximum speed value to be programmed:

**Max. programmable speed → rated speed \* (maximum output frequency/rated frequency)**  
 where the maximum output frequency results from the following:

$$\begin{aligned} \text{C002} > 5000\text{Hz} & \quad f_{\text{out\_max}} = \text{C002} / 16 \\ \text{C002} \leq 5000\text{Hz} & \quad f_{\text{out\_max}} = \text{C002} / 10 \end{aligned}$$

**C002** is the maximum carrier frequency and the divisor is the min. allowable number of pulses per period.

**Table 69: Maximum value of the output frequency depending on the Penta size**

| Size              | Max. output frequency (Hz) (*) |
|-------------------|--------------------------------|
|                   | 2T/4T                          |
| Smaller than 0015 | 1000                           |
| 0015 to 0129 (**) | 625                            |
| 0150 to 0162      | 500                            |
| Greater than 0162 | 400                            |

(\*\*) From 0023 to 0030 (437.5Hz), 0040 (1000Hz) and 0049 (800Hz)

| Size              | Max. Output Frequency (Hz) (*) |
|-------------------|--------------------------------|
|                   | 5T/6T                          |
| Smaller than 0076 | 500                            |
| 0076 to 0524      | 400                            |
| Greater than 0524 | 200                            |



(\*) **NOTE** The maximum output frequency is limited to the speed level programmed in parameters **C028**, **C029** [-32000 ÷ 32000]rpm. This results in  $F_{\text{out\_max}} = (\text{RPM}_{\text{max}} * \text{NPole}) / 120$ .

**EXAMPLE:**

When using a 4-pole motor and 30,000rpm are required,  $F_{\text{out}}$  will be 1000Hz, so the performance requirements are fulfilled.

On the other hand, if the same performance requirements are needed with an 8-pole system, 30,000rpm cannot be obtained, as  $F_{\text{out}}$  is 2000Hz. As a result, when using an 8-pole motor, the maximum allowable programmable speed is 15,000rpm [ $\text{RPM}_{\text{outmax}} = (F_{\text{outmax}} * 120) / (\text{number of motor poles})$ ].

### 33.2. List of Parameters C001 to C004

Table 70: List of parameters C001 to C004

| Parameter   | FUNCTION                  | User Level  | MODBUS Address | Default Values            |
|-------------|---------------------------|-------------|----------------|---------------------------|
| <b>C001</b> | Minimum carrier frequency | ENGINEERING | 1001           | See Table 79 and Table 83 |
| <b>C002</b> | Maximum carrier frequency | ENGINEERING | 1002           | See Table 79 and Table 83 |
| <b>C003</b> | Number of pulses          | ENGINEERING | 1003           | 1:[24]                    |
| <b>C004</b> | Silent modulation         | ENGINEERING | 1004           | See Table 79 and Table 83 |

The default value and the max. value of carrier frequency (**C001** and **C002**) depend on the drive size. To check those values, see Table 79 and Table 83.

#### C001 Minimum Carrier Frequency

|             |                 |  |  |
|-------------|-----------------|--|--|
| <b>C001</b> | <b>Range</b>    | 1600 ÷ 16000<br><i>Depending on the drive model</i>                  | 1600 ÷ 16000 Hz<br><i>Depending on the drive model – See Table 79 and Table 83</i> |
|             | <b>Default</b>  | See Table 79 and Table 83  |  |
|             | <b>Level</b>    | ENGINEERING  |  |
|             | <b>Address</b>  | 1001   |  |
|             | <b>Control</b>  | IFD and VTC  |  |
|             | <b>Function</b> | It represents the min. value of the modulation frequency being used. |  |



**NOTE** The min. value set in **C001** cannot exceed the max. value set in **C002**. Increase the max. value in **C002** if you need to increase the min. value and if **C001** equals **C002**.

#### C002 Maximum Carrier Frequency

|             |                 |  |   |
|-------------|-----------------|--|---|
| <b>C002</b> | <b>Range</b>    | 1600 ÷ 16000<br><i>Depending on the drive size</i>   | 1600 ÷ 16000 Hz<br><i>Depending on the drive model – See Table 79 and Table 83.</i> |
|             | <b>Default</b>  | See Table 79 and Table 83.   |   |
|             | <b>Level</b>    | ENGINEERING  |   |
|             | <b>Address</b>  | 1002   |   |
|             | <b>Function</b> | It represents the max. value of the modulation frequency being used. As per FOC control, the modulation frequency set in <b>C002</b> is used only if exceeding 8 kHz (when the max. allowable carrier frequency is > 8kHz). Otherwise, the max. carrier frequency allowed is used for the models implementing a carrier frequency <8 kHz, independently of <b>C002</b> . |   |



**NOTE** The max. value set in **C002** cannot be lower than the min. value set in **C001**. Decrease the min. value in **C001** if you need to decrease the max. value and if **C001** equals **C002**.



**NOTE** The max. value in **C002** also determines the max. allowable speed value for the selected motor, in order to ensure a minimum number of pulses per period of frequency produced. This value is 16 for maximum carrier frequency (max. **C002** value) greater than 5kHz and 10 for lower maximum carrier frequency (see Table 79 and Table 83).

**C003 Pulse Number**

|             |                 |  |   |
|-------------|-----------------|--|---|
| <b>C003</b> | <b>Range</b>    | 0-5  | 0: [12] 1: [24]<br>2: [48] 3: [96]<br>4: [192] 5: [384] |
|             | <b>Default</b>  | 1  | 1: [24]   |
|             | <b>Level</b>    | ENGINEERING  |   |
|             | <b>Address</b>  | 1003   |   |
|             | <b>Control</b>  | IFD and VTC  |   |
|             | <b>Function</b> | This parameter has effect only if <b>C001</b> ≠ <b>C002</b> . It represents the min. value of pulses per period obtained when modulation frequency changes (synchronous modulation). |   |

**C004 Silent Modulation**

|             |                 |  |                   |
|-------------|-----------------|--|-------------------|
| <b>C004</b> | <b>Range</b>    | 0-1  | 0: [No]; 1: [Yes] |
|             | <b>Default</b>  | See Table 79 and Table 83  |                   |
|             | <b>Level</b>    | ENGINEERING  |                   |
|             | <b>Address</b>  | 1004   |                   |
|             | <b>Function</b> | This parameter enables silent modulation. The electric noise due to the switching frequency is dampened. |                   |

## 34. MOTOR CONFIGURATION MENU

### 34.1. Overview

---

The Sinus Penta allows configuring three different types of motors and three different types of control algorithms at the same time.

The three types of control algorithms are identified with the acronyms

- ✓ **IFD** (Voltage/Frequency Control);
- ✓ **VTC** (Vector Torque Control);
- ✓ **FOC** (Field Oriented Control).

The **Voltage/Frequency control** allows controlling the motor by producing voltage depending on frequency.

The **Vector Torque Control (sensorless)** processes the machine equations depending on the equivalent parameters of the asynchronous machine. It also allows separating torque control from flux control with no need to use a transducer.

The **Field Oriented Control** is a closed-chain control requiring a speed transducer to detect the position of the motor shaft instant by instant.

The parameter set for the selected motor is included in the Motor Control menu:

- ✓ Motor Control 1 Menu concerns motor 1;
- ✓ Motor Control 2 Menu concerns motor 2;
- ✓ Motor Control 3 Menu concerns motor 3.

Factory setting allows configuring only one motor. To access the Configuration menus of the other connected motors, simply enter the number of the selected motor in **C009** (Number of Configured Motors) in the Motor Control 1 Menu.

To select the connected motor, use digital inputs programmed with parameters **C173** and **C174**, Digital Input for Motor 2 Activation and Digital Input for Motor 3 Activation respectively (see also the DIGITAL INPUTS MENU).

The parameters included in the Motor Control Menus are detailed in the table below.

Table 71: Description of the parameters classified by motor

| Parameter Contents  | Motor Control 1  | Motor Control 2  | Motor Control 3  |
|---|------------------|------------------|------------------|
| Mains rated voltage   | C008             | _____            | _____            |
| Control algorithm being used  | C010             | C053             | C096             |
| Type of reference being used (speed/torque)<br>(see Torque Control (VTC and FOC Only)                                 | C011             | C054             | C097             |
| Availability of the speed feedback from encoder   | C012             | C055             | C098             |
| Electric ratings of the motor   | C015 ÷ C025      | C058 ÷ C068      | C101 ÷ C111      |
| Max. speed and min. speed required, speed at the beginning of flux weakening, max. speed alarm threshold and enabling | C028 ÷ C031      | C071 ÷ C074      | C114 ÷ C117      |
| V/f pattern parameters  | C013/C032 ÷ C038 | C056/C075 ÷ C081 | C099/C118 ÷ C124 |
| Slip compensation activation  | C039             | C082             | C125             |
| Drop in rated current voltage   | C040             | C083             | C126             |
| Fluxing ramp time   | C041             | C084             | C127             |

The parameters that can be modified depend on the type of control that has been selected.

### 34.1.1. ELECTRICAL SPECIFICATIONS OF THE CONNECTED MOTOR

This group of parameters can be divided into two subunits: the first subunit includes the motor ratings, the second subunit includes the parameters of the equivalent circuit of the asynchronous machine being used.

### 34.1.2. MOTOR RATINGS

Table 72: Motor ratings

| Motor Ratings   | Motor 1 | Motor 2 | Motor 3 |
|-----------------|---------|---------|---------|
| Rated frequency | C015    | C058    | C101    |
| Rated rpm       | C016    | C059    | C102    |
| Rated power     | C017    | C060    | C103    |
| Rated current   | C018    | C061    | C104    |
| Rated voltage   | C019    | C062    | C105    |
| No-load power   | C020    | C063    | C106    |
| No-load current | C021    | C064    | C107    |

### 34.1.3. PARAMETERS OF THE EQUIVALENT CIRCUIT OF THE ASYNCHRONOUS MACHINE

**Table 73: Parameters of the equivalent circuit of the asynchronous machine**

| Description         | Motor 1 | Motor 2 | Motor 3 |
|---------------------|---------|---------|---------|
| Stator resistance   | C022    | C065    | C108    |
| Leakage inductance  | C023    | C066    | C109    |
| Mutual inductance   | C024    | C067    | C110    |
| Rotor time constant | C025    | C068    | C111    |

**Figure 41: Equivalent circuit of the asynchronous machine**

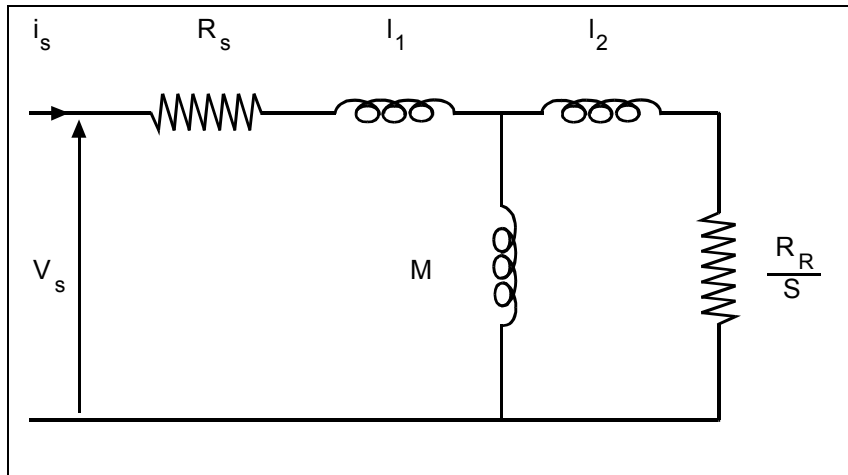

Where:

- R<sub>s</sub>: Stator resistance (wires included)
- R<sub>r</sub>: Rotor resistance
- l<sub>1</sub>+l<sub>2</sub>: Full leakage inductance
- M: Mutual inductance (not required for control implementation)
- S: Slip
- $\tau_{rot.} \cong M / R_r$  rotor time constant.

Because the motor characteristics are generally unknown, the Sinus Penta is capable of automatically determining the motor characteristics (see the FIRST STARTUP section and the AUTOTUNE MENU). However, some parameters may be manually adjusted to meet the requirements needed for special applications.

The parameters used for the different control algorithms are stated in the table below.

**Table 74: Motor parameters used by control algorithms**

| Parameter           | IFD | VTC | FOC |
|---------------------|-----|-----|-----|
| Stator resistance   | v   | v   | v   |
| Leakage inductance  | —   | v   | —   |
| Mutual inductance   | —   | v   | v   |
| Rotor time constant | —   | v   | v   |

v Used ; — Not used



**NOTE**

**Because the value of the stator resistance is used for any type of control, always perform the autotune procedure with I073= Motor Tune and I074= 0: All no rotation.**

### 34.1.4. V/F PATTERN (IFD ONLY)

This group of parameters which is included in the **Motor Control Menu** defines the V/f pattern trend of the drive when it is used as an IFD control algorithm. When setting the type of V/f pattern (e.g. **C013** for motor 1), the following curves can be used:

- Constant torque
- Quadratic
- Free setting

The diagram below illustrates three types of programmable curves compared to the theoretical V/f curve.

If **C013 = Constant Torque**, Preboost parameter **C034** allows changing the starting voltage value if compared to the theoretical V/f curve (this allows torque compensation for losses caused by the stator impedance and a greater torque at lower revs).

If **C013 = Quadratic**, the drive will follow a V/f pattern with a parabolic trend. You can set the starting voltage value (**C034**), the desired voltage drop if compared to the relevant constant torque (use **C032**) and the frequency allowing implementing this torque reduction (use **C033**).

If **C013 = Free Setting**, you can program the starting voltage (**C034 Preboost**), the increase in voltage to 1/20 of the rated frequency (**C035 Boost0**), and the increase in voltage (**C036 Boost1**) at programmable frequency (**C037 Frequency for Boost1**).

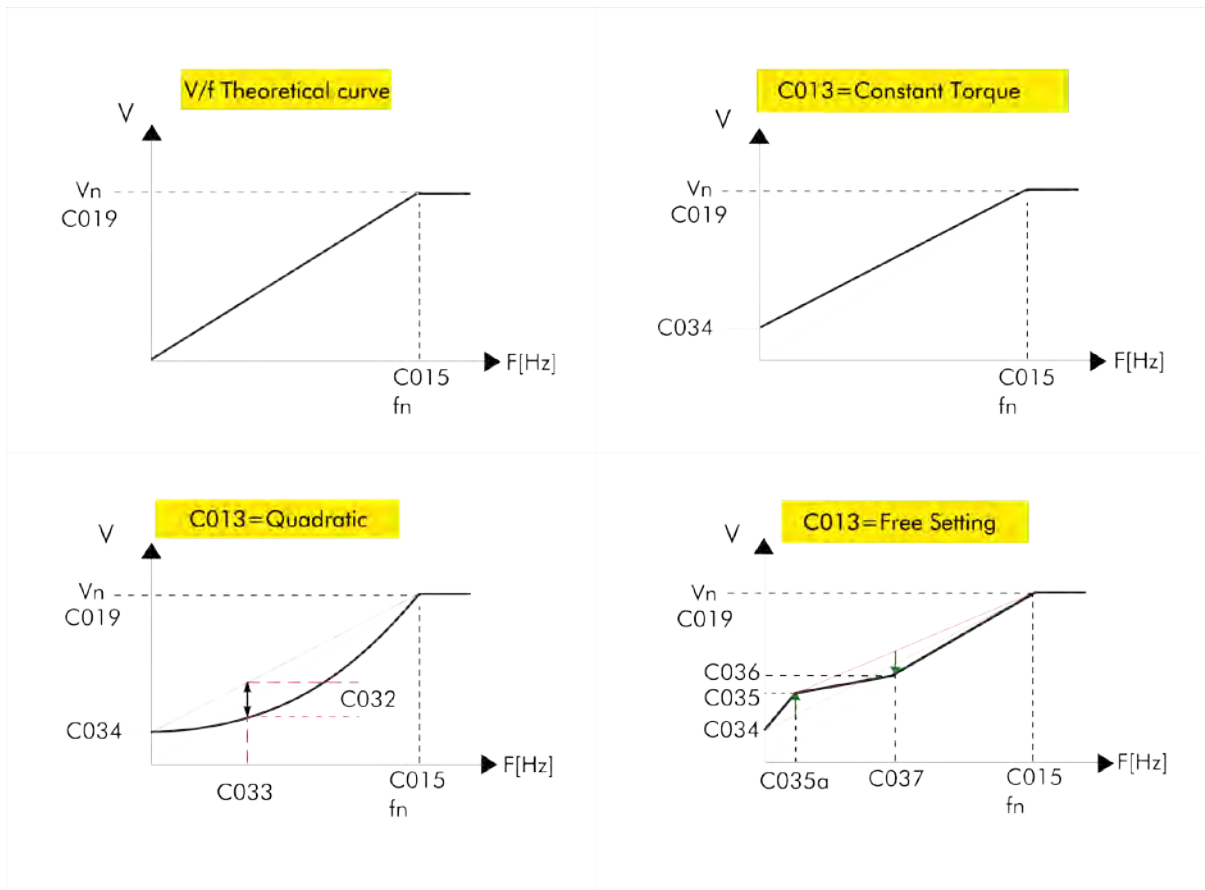

Figure 42: Types of programmable V/f curves

The voltage produced by the drive may be changed also by setting the **Automatic increase in torque curve** parameter (**C038 for motor 1**).

For the description of the parameters used in the figure above, see table below.

Table 75: IFD control parameters for the connected motors

| Parameter  | Motor 1      | Motor 2      | Motor 3      |
|--|--------------|--------------|--------------|
| <b>Rated frequency:</b><br>Rated frequency of the connected motor (current rating).  | <b>C015</b>  | <b>C058</b>  | <b>C101</b>  |
| <b>Rated voltage:</b> rated voltage of the connected motor (voltage rating).   | <b>C019</b>  | <b>C062</b>  | <b>C105</b>  |
| <b>V/f curve type:</b><br>Type of V/f curve applied.   | <b>C013</b>  | <b>C056</b>  | <b>C099</b>  |
| <b>Torque reduction with quadratic curve:</b><br>Torque reduction using V/f quadratic curve.   | <b>C032</b>  | <b>C075</b>  | <b>C118</b>  |
| <b>Rated speed referring to torque reduction with quadratic curve:</b><br>Speed actuating the torque reduction using a quadratic curve.  | <b>C033</b>  | <b>C076</b>  | <b>C119</b>  |
| <b>Voltage preboost:</b><br>Determines the voltage produced by the drive at min. output frequency fomin.   | <b>C034</b>  | <b>C077</b>  | <b>C120</b>  |
| <b>Voltage Boost 0:</b><br>Determines the voltage variations in respect to the nominal voltage at the frequency set up by the relevant parameter.  | <b>C035</b>  | <b>C078</b>  | <b>C121</b>  |
| <b>Boost 0 application frequency:</b><br>Determines the Boost 0 application frequency.   | <b>C035a</b> | <b>C078a</b> | <b>C121a</b> |
| <b>Voltage Boost 1:</b><br>Determines the frequency for the application of the boost at preset frequency.  | <b>C036</b>  | <b>C079</b>  | <b>C122</b>  |
| <b>Boost 1 application frequency:</b><br>Determines the Boost 1 application frequency at preset frequency.   | <b>C037</b>  | <b>C080</b>  | <b>C123</b>  |
| <b>Autoboost:</b><br>Variable torque compensation expressed as a percentage of the rated motor voltage. The preset value expresses the voltage increase when the motor is running at rated torque. | <b>C038</b>  | <b>C081</b>  | <b>C124</b>  |

### 34.1.5. EXAMPLE 1 - V/F PATTERN PARAMETERIZATION

Motor 1: the voltage/frequency pattern is to be programmed for an asynchronous motor (400V/50Hz) with a rated speed of 1500rpm up to 2000rpm.

|                   |             |   |                                  |
|-------------------|-------------|---|----------------------------------|
| Type of V/f curve | <b>C013</b> | = | Constant Torque                  |
| Rated frequency   | <b>C015</b> | = | 50 Hz                            |
| Rated motor rpm   | <b>C016</b> | = | 1500rpm                          |
| Rated voltage     | <b>C019</b> | = | 400 V                            |
| Preboost          | <b>C034</b> | = | depending on the starting torque |
| Max. speed        | <b>C029</b> | = | 2000rpm                          |

### 34.1.6. EXAMPLE 2 - V/F PATTERN PARAMETERIZATION

The voltage/frequency pattern is to be programmed for an asynchronous motor (400V/50Hz) having a rated power of 7.5 kW and a rated speed of 1420 rpm with a voltage compensation depending on the motor torque:

|                     |             |   |                                  |
|---------------------|-------------|---|----------------------------------|
| Type of V/f pattern | <b>C013</b> | = | Constant Torque                  |
| Rated frequency     | <b>C015</b> | = | 50 Hz                            |
| Motor rpm           | <b>C016</b> | = | 1420rpm                          |
| Rated power         | <b>C017</b> | = | 7.5kW                            |
| Rated voltage       | <b>C019</b> | = | 400 V                            |
| Preboost            | <b>C034</b> | = | depending on the starting torque |
| Autoboost           | <b>C038</b> | = | 4%                               |

Voltage compensation (AutoBoost) results from the formula below:

$$\Delta V = C019 \times (C038/100) \times (T/Tn)$$

Where T is the estimated motor torque and Tn is the rated motor torque.

Tn is calculated as follows:

$$Tn = (Pn \times \text{pole pairs} / 2\pi f) = (C017 \times \text{pole pairs}) / (2\pi \times C015)$$

“Pole pairs” is the integer number obtained by rounding down (60\* C015/C016).

The programmable parameters relating to the AutoBoost functions are the following:

**C038** (AutoBoost): variable torque compensation expressed as a percentage of the motor rated voltage (**C019**). The value set in **C038** is the voltage increase when the motor is running at its rated torque.

**C017** (Pn): rated power of the connected motor.

### 34.1.7. SLIP COMPENSATION (IFD ONLY)

This function allows compensating the speed decrease of the asynchronous motor when the mechanical load increases (slip compensation). This is available for IFD control only.

The parameters relating to this function are included in the Motor Control Menu (Configuration Menu).

**Table 76: Parameters setting Slip Compensation (IFD Control)**

| Parameter  | Motor 1     | Motor 2     | Motor 3     |
|--|-------------|-------------|-------------|
| <b>Rated voltage:</b><br>Rated voltage of the connected motor (voltage rating).  | <b>C019</b> | <b>C062</b> | <b>C105</b> |
| <b>No-load power:</b><br>Power absorbed by the motor when no load is connected to the motor; it is expressed as a percentage of the motor rated power. | <b>C020</b> | <b>C063</b> | <b>C106</b> |
| <b>Stator resistance:</b><br>Determines the resistance of the stator phases used to compute the power consumption due to Joule effect.                 | <b>C022</b> | <b>C065</b> | <b>C108</b> |
| <b>Activation of slip compensation:</b><br>If other than zero, this parameter enables slip compensation and defines its relevant value.                | <b>C039</b> | <b>C082</b> | <b>C125</b> |

Once the drive output power has been estimated and the power losses due to the Joule effect and to the mechanical parts (depending on output voltage and no-load power) have been subtracted, mechanical power is obtained. Starting from mechanical power and the value set for slip compensation (**C039** for motor 1), you can obtain the increase of the output frequency limiting the error between the desired speed value and the actual speed value of the connected motor.

### 34.1.8. TORQUE CONTROL (VTC AND FOC ONLY)

VTC and FOC controls allow controlling the drive with a torque reference instead of a speed reference. To do so, set [1: Torque or 2: Torque with Speed Limit [FOC only] in the relevant parameter (**C011** for motor 1, **C054** for motor 2, **C097** for motor 3).

In this way, the main reference corresponds to the motor torque demand and may range from **C047** to **C048 (Limits Menu)** for motor 1 (minimum and maximum torque expressed as a percentage of the motor rated torque). For motors 2 and 3, the parameters relating to min. and max. torque (**C090**, **C091** and **C133**, **C134**) are included in the Limits Menu 2 and Limits Menu 3.

Using a 0020 drive connected to a 15kW motor, **C048** is factory-set to 120% of the motor rated torque. If the max. reference is applied (**C143** = REF), the torque reference will be 120%.

If a 7.5kW motor is connected, **C048** may exceed 200%; torque values exceeding 200% may be obtained based on the value set in **C048**.

The motor rated torque results from the following formula:

$$C = P / \omega$$

where P is the rated power expressed in W and  $\omega$  is the rated speed of rotation expressed in radians/sec.

Example: the rated torque of a 15kW motor at 1420rpm is equal to:

$$C = \frac{15000}{1420 \cdot 2\pi / 60} = 100.9 \text{ Nm}$$

The starting torque is:

$$\text{rated torque} * 120\% = 121.1 \text{ Nm}$$

### 34.2. List of Parameters C008 to C128

Table 77: List of parameters C008 to C128

| Parameter | FUNCTION                | User Level  | MODBUS Address | DEFAULT VALUES |
|-----------|-------------------------|-------------|----------------|----------------|
| C008      | Rated mains voltage     | BASIC       | 1008           | 2:[380÷480V]   |
| C009      | N. of configured motors | ENGINEERING | 1009           | 1              |

| Parameter | FUNCTION                    | User Level  | MODBUS Address | DEFAULT VALUES                       |
|-----------|-----------------------------|-------------|----------------|--------------------------------------|
| C010 M1   | Type of control algorithm   | BASIC       | 1010           | 0: IFD                               |
| C053 M2   |                             |             | 1053           |                                      |
| C096 M3   |                             |             | 1096           |                                      |
| C011 M1   | Type of reference           | ADVANCED    | 1011           | 0: Speed (MASTER mode)               |
| C054 M2   |                             |             | 1054           |                                      |
| C097 M3   |                             |             | 1097           |                                      |
| C012 M1   | Speed feedback from encoder | BASIC       | 1012           | 0: No                                |
| C055 M2   |                             |             | 1055           |                                      |
| C098 M3   |                             |             | 1098           |                                      |
| C013 M1   | Type of V/f curve           | BASIC       | 1013           | See Table 81 and Table 85            |
| C056 M2   |                             |             | 1056           |                                      |
| C099 M3   |                             |             | 1099           |                                      |
| C014 M1   | Phase rotation              | ENGINEERING | 1014           | 0: No                                |
| C057 M2   |                             |             | 1057           |                                      |
| C100 M3   |                             |             | 1100           |                                      |
| C015 M1   | Rated motor frequency       | BASIC       | 1015           | 50.0 Hz                              |
| C058 M2   |                             |             | 1058           |                                      |
| C101 M3   |                             |             | 1101           |                                      |
| C016 M1   | Rated motor rpm             | BASIC       | 1016           | 1420 rpm                             |
| C059 M2   |                             |             | 1059           |                                      |
| C102 M3   |                             |             | 1102           |                                      |
| C017 M1   | Rated motor power           | BASIC       | 1017           | See Table 82 and Table 86            |
| C060 M2   |                             |             | 1060           |                                      |
| C103 M3   |                             |             | 1103           |                                      |
| C018 M1   | Rated motor current         | BASIC       | 1018           | See Table 82 and Table 86            |
| C061 M2   |                             |             | 1061           |                                      |
| C104 M3   |                             |             | 1104           |                                      |
| C019 M1   | Rated motor voltage         | BASIC       | 1019           | Depending on the drive voltage class |
| C062 M2   |                             |             | 1062           |                                      |
| C105 M3   |                             |             | 1105           |                                      |
| C020 M1   | Motor no-load power         | ADVANCED    | 1020           | 0.0%                                 |
| C063 M2   |                             |             | 1063           |                                      |
| C106 M3   |                             |             | 1106           |                                      |
| C021 M1   | Motor no-load current       | ADVANCED    | 1021           | 0%                                   |
| C064 M2   |                             |             | 1064           |                                      |
| C107 M3   |                             |             | 1107           |                                      |
| C022 M1   | Motor stator resistance     | ENGINEERING | 1022           | See Table 82 and Table 86            |
| C065 M2   |                             |             | 1065           |                                      |
| C108 M3   |                             |             | 1108           |                                      |
| C023 M1   | Leakage inductance          | ENGINEERING | 1023           | See Table 82 and Table 86            |
| C066 M2   |                             |             | 1066           |                                      |
| C109 M3   |                             |             | 1109           |                                      |

| Parameter |    | FUNCTION  | User Level  | MODBUS Address | DEFAULT VALUES            |
|-----------|----|---|-------------|----------------|---------------------------|
| C024      | M1 | Mutual inductance   | ADVANCED    | 1024           | 250.00mH                  |
| C067      | M2 |   |             | 1067           |                           |
| C110      | M3 |   |             | 1110           |                           |
| C025      | M1 | Rotor time constant   | ADVANCED    | 1025           | 0 ms                      |
| C068      | M2 |   |             | 1068           |                           |
| C111      | M3 |   |             | 1111           |                           |
| C026      | M1 | Time constant of bus voltage low-pass filter                | ENGINEERING | 1026           | 0 ms                      |
| C069      | M2 |   |             | 1069           |                           |
| C112      | M3 |   |             | 1112           |                           |
| C028      | M1 | Min. motor speed  | BASIC       | 1028           | 0 rpm                     |
| C071      | M2 |   |             | 1071           |                           |
| C114      | M3 |   |             | 1114           |                           |
| C029      | M1 | Max. motor speed  | BASIC       | 1029           | 1500 rpm                  |
| C072      | M2 |   |             | 1072           |                           |
| C115      | M3 |   |             | 1115           |                           |
| C030      | M1 | Flux weakening speed  | ENGINEERING | 1030           | 90%                       |
| C073      | M2 |   |             | 1073           |                           |
| C116      | M3 |   |             | 1116           |                           |
| C031      | M1 | Max. speed alarm  | ADVANCED    | 1031           | 0: Disabled               |
| C074      | M2 |   |             | 1074           |                           |
| C117      | M3 |   |             | 1117           |                           |
| C032      | M1 | Reduction in quadratic torque curve                         | ADVANCED    | 1032           | 30%                       |
| C075      | M2 |   |             | 1075           |                           |
| C118      | M3 |   |             | 1118           |                           |
| C033      | M1 | Rated revs referring to reduction in quadratic torque curve | ADVANCED    | 1033           | 20%                       |
| C076      | M2 |   |             | 1076           |                           |
| C119      | M3 |   |             | 1119           |                           |
| C034      | M1 | Voltage Preboost for IFD                                    | BASIC       | 1034           | See Table 81 and Table 85 |
| C077      | M2 |   |             | 1077           |                           |
| C120      | M3 |   |             | 1120           |                           |
| C035      | M1 | Voltage Boost 0 at programmable frequency                   | ADVANCED    | 1035           | See Table 81 and Table 85 |
| C078      | M2 |   |             | 1078           |                           |
| C121      | M3 |   |             | 1121           |                           |
| C035a     | M1 | Frequency for Boost 0 application                           | ADVANCED    | 1052           | 5%                        |
| C078a     | M2 |   |             | 1070           |                           |
| C121a     | M3 |   |             | 1113           |                           |
| C036      | M1 | Voltage Boost 1 at programmable frequency                   | ADVANCED    | 1036           | See Table 81 and Table 85 |
| C079      | M2 |   |             | 1079           |                           |
| C122      | M3 |   |             | 1122           |                           |
| C037      | M1 | Frequency for application of voltage Boost 1                | ADVANCED    | 1037           | See Table 81 and Table 85 |
| C080      | M2 |   |             | 1080           |                           |
| C123      | M3 |   |             | 1123           |                           |
| C038      | M1 | Autoboost   | ADVANCED    | 1038           | See Table 81 and Table 85 |
| C081      | M2 |   |             | 1081           |                           |
| C124      | M3 |   |             | 1124           |                           |
| C039      | M1 | Slip compensation   | ADVANCED    | 1039           | 0: Disabled               |
| C082      | M2 |   |             | 1082           |                           |
| C125      | M3 |   |             | 1125           |                           |
| C040      | M1 | Voltage drop at rated current                               | ADVANCED    | 1040           | 0: Disabled               |
| C083      | M2 |   |             | 1083           |                           |
| C126      | M3 |   |             | 1126           |                           |

| Parameter |    | FUNCTION                   | User Level  | MODBUS Address | DEFAULT VALUES            |
|-----------|----|----------------------------|-------------|----------------|---------------------------|
| C041      | M1 | Fluxing ramp time          | ENGINEERING | 1041           | See Table 80 and Table 84 |
| C084      | M2 |                            |             | 1084           |                           |
| C127      | M3 |                            |             | 1127           |                           |
| C042      | M1 | Vout saturation percentage | ENGINEERING | 1042           | 100%                      |
| C085      | M2 |                            |             | 1085           |                           |
| C128      | M3 |                            |             | 1128           |                           |

**C008 Rated Mains Voltage**

|             |                 |  |  |
|-------------|-----------------|--|--|
| <b>C008</b> | <b>Range</b>    | 0 ÷ 8  | 0: [ 200 ÷ 240 ] V<br>1: 2T Regen.<br>2: [ 380 ÷ 480 ] V<br>3: [ 481 ÷ 500 ] V<br>4: 4T Regen.<br>5: [ 500 ÷ 600 ] V<br>6: 5T Regen.<br>7: [ 600 ÷ 690 ] V<br>8: 6T Regen. |
|             | <b>Default</b>  | 2  | 2: [ 380 ÷ 480 ] V   |
|             | <b>Level</b>    | BASIC  |  |
|             | <b>Address</b>  | 1008   |  |
|             | <b>Function</b> | This parameter defines the rated voltage of the mains powering the drive, thus allowing obtaining voltage ranges to be used for the drive operation. The value set in this parameter depends on the <b>Drive voltage class</b> .<br>To supply the drive via a non-stabilized DC source, the corresponding AC voltage range must be used (see Table 78). DO NOT USE xT Regen settings in this case. |  |

**Table 78: Equivalence between AC mains range and DC range**

| AC Mains    | DC range    |
|-------------|-------------|
| 200÷240 Vac | 280÷338 Vdc |
| 380÷480 Vac | 530÷678 Vdc |
| 481÷500 Vac | 680÷705 Vdc |
| 500÷600 Vac | 705÷810 Vdc |
| 600÷690 Vac | 810÷970 Vdc |



NOTE

**Select xT Regen** (where x relates to the voltage class of the drive) **if the drive is DC-supplied through a regenerative Sinus Penta or a different drive used to stabilize the DC bus to a higher level than the stabilization level obtained when rectifying the 3-phase mains.**

**C009 N. of Configured Motors**

|             |                 |  |     |
|-------------|-----------------|--|-----|
| <b>C009</b> | <b>Range</b>    | 1÷3  | 1÷3 |
|             | <b>Default</b>  | 1  | 1   |
|             | <b>Level</b>    | ENGINEERING  |     |
|             | <b>Address</b>  | 1009   |     |
|             | <b>Function</b> | This parameter determines the number of motors to be configured. The active motor is selected through digital inputs programmed with <b>C173</b> and <b>C174</b> (see the DIGITAL INPUTS MENU).<br>The programming parameters of the Motor Control 2 Menu can be accessed only if <b>C009</b> = 2 or 3; the programming parameters of the Motor Control 3 Menu can be accessed only if <b>C009</b> =3. |     |

**C010 (C053, C096) Type of Control Algorithm**

|   |                      |  |                            |
|---|----------------------|--|----------------------------|
| <b>C010 (Motor 1)</b><br><b>C053 (Motor 2)</b><br><b>C096 (Motor 3)</b> | <b>Range</b>         | 0 ÷ 2  | 0: IFD<br>1: VTC<br>2: FOC |
|   | <b>Default Level</b> | 0  | 0: IFD                     |
|   | <b>Address</b>       | 1010<br>1053<br>1096   |                            |
|   | <b>Function</b>      | <p>This parameter sets the type of control algorithm to be used.</p> <p>Type of controls:<br/>                     0: IFD V/f control<br/>                     1: VTC Sensorless Vector Torque control<br/>                     2: FOC Field Oriented Control</p> <p>The <b>V/f control (IFD)</b> allows controlling the motor by producing voltage depending on frequency. It is possible to configure several types of V/f patterns (see V/f Pattern (IFD Only)).</p> <p>The <b>Sensorless Vector Control (VTC)</b> and <b>Field Oriented Control (FOC)</b> are field-oriented control modes.</p> <p>The FOC is a closed-loop control, so a speed transducer is required to detect the position of the shaft of the connected motor.</p> <p>The VTC is a control mode w/out speed feedback, so no position/speed transducer is required: based on a dynamic model of an asynchronous motor, the algorithm estimates the speed and orientation of the motor flux.</p> <p>Both controllers guarantee segregation between the flux control and the torque control. In that way, the motor flux is adjusted based on the magnetizing current, obtained from <b>No-load current C021 (C064 for motor 2 and C107 for motor 3)</b>.</p> <p>When the VTC or FOC controls are used, the connected motor can be controlled either via a torque reference or via a speed reference; in that case, the speed control loop, based on the error between reference speed and measured speed (FOC) or the estimated speed (VTC) is the external control loop for the torque controller.</p> <p>The equations used for VTC and FOC control algorithms require the following equivalent parameters of the asynchronous device:<br/> <b>stator resistance C022 (C065 for motor 2, C108 for motor 3),</b><br/> <b>mutual inductance C024 (C067 for motor 2, C110 for motor 3)</b> and<br/> <b>rotor time constant C025 (C068 for motor 2, C111 for motor 3).</b><br/>                     As per VTC, the following value is required<br/> <b>leakage inductance C023 (C066 for motor 2 and C109 for motor 3).</b></p> |                            |



**NOTE** FOC control requires a speed transducer, such as an encoder feedback.



**CAUTION** It is not advisable to set VTC and FOC algorithms with a nominal current motor lower than 50% of the drive size, otherwise the control performance is not guaranteed.

**C011 (C054, C097) Type of Reference (Master/Slave)**

|   |                 |   |  |
|---|-----------------|---|--|
| <b>C011 (Motor 1)<br/>C054 (Motor 2)<br/>C097 (Motor 3)</b> | <b>Range</b>    | 0 ÷ 2   | 0: Speed (MASTER mode)<br>1: Torque (SLAVE mode)<br>2: Torque with speed limit (SLAVE mode) (FOC only) |
|   | <b>Default</b>  | 0   | 0: Speed (MASTER mode)   |
|   | <b>Level</b>    | ADVANCED  |  |
|   | <b>Address</b>  | 1011, 1054, 1097  |  |
|   | <b>Control</b>  | VTC and FOC   |  |
|   | <b>Function</b> | <p>This parameter defines the type of reference to be used. The torque control may be set up (see section Torque Control (VTC and FOC Only) as well).</p> <p>When the Torque control with speed limit mode is used, the drive will limit the motor rotation to the rpm set in parameter <b>C029 (C072, C115)</b>.</p> <p>This function can be used to automatically toggle from the torque control mode to the speed control mode: when the torque control mode is implemented, the motor speed can reach any value included in the "AB" area (see figure below). If the limit speed is attained due to particular load conditions, the drive will automatically switch to the speed control ("BC" zone). The controlled torque is no longer maintained.</p> <p>If the torque returns to its setpoint value, the drive will automatically switch to the torque control again ("AB" zone).</p> |  |

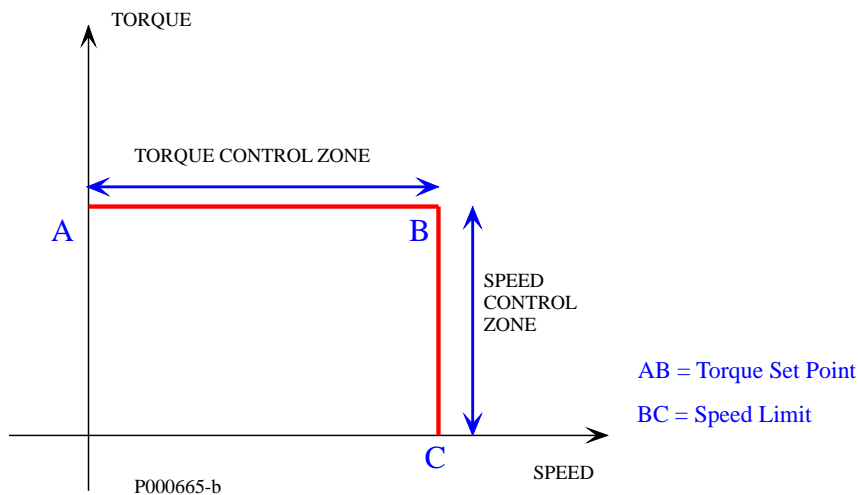

**Figure 43: Torque control with speed limit**



**NOTE** Mode 2 can be selected only if a FOC control is implemented.

**C012 (C055, C098) Speed Feedback from Encoder**

|   |                 |  |                 |
|---|-----------------|--|-----------------|
| <b>C012 (Motor 1)<br/>C055 (Motor 2)<br/>C098 (Motor 3)</b> | <b>Range</b>    | 0 ÷ 1  | 0: No<br>1: Yes |
|   | <b>Default</b>  | 0  | 0 ÷ 1           |
|   | <b>Level</b>    | BASIC  |                 |
|   | <b>Address</b>  | 1012, 1055, 1098   |                 |
|   | <b>Control</b>  | VTC and FOC  |                 |
|   | <b>Function</b> | This parameter enables the encoder as a speed feedback. It defines the encoder characteristics and whether Encoder A (MDI6 and MDI7 in the terminal board) or Encoder B (with optional board) is used as a speed feedback (see the ENCODER/FREQUENCY INPUTS MENU). |                 |

**C013 (C056, C099) Type of V/F Pattern**

|   |                 |  |   |
|---|-----------------|--|---|
| <b>C013 (Motor 1)<br/>C056 (Motor 2)<br/>C099 (Motor 3)</b> | <b>Range</b>    | 0 ÷ 2  | 0: Constant Torque<br>1: Quadratic<br>2: Free Setting |
|   | <b>Default</b>  | See Table 81 and Table 85  |   |
|   | <b>Level</b>    | BASIC  |   |
|   | <b>Address</b>  | 1013, 1056, 1099   |   |
|   | <b>Control</b>  | IFD  |   |
|   | <b>Function</b> | Allows selecting different types of V/f pattern.<br><br>If <b>C013 (C056,C099) = Constant torque</b> , voltage at zero frequency can be selected (Preboost <b>C034 (C077,C120)</b> ).<br><br>If <b>C013 (C056,C099) = Quadratic</b> , you can select voltage at zero frequency (preboost, <b>C034 (C077,C120)</b> ), max. voltage drop with respect to the theoretical V/f pattern, <b>C032 (C075 C118)</b> , and the frequency allowing implementing max. voltage drop, <b>C033 (C076 C119)</b> .<br><br>If <b>C013 (C056,C099) = Free Setting</b> , you can set voltage at zero frequency (preboost, <b>C034(C077,C120)</b> ); voltage increase to 20% of the rated frequency (Boost0, <b>C035 (C078,C121)</b> ); and voltage increase to a programmed frequency (Boost1, <b>C036 (C079,C122)</b> ; frequency for Boost1, <b>C037 (C080,C123)</b> ). |   |

**C014 (C057, C100) Phase Rotation**

|   |                 |  |                   |
|---|-----------------|--|-------------------|
| <b>C014 (Motor 1)<br/>C057 (Motor 2)<br/>C100 (Motor 3)</b> | <b>Range</b>    | 0÷1  | 0: [No]; 1: [Yes] |
|   | <b>Default</b>  | 0  | 0: [No]           |
|   | <b>Level</b>    | ENGINEERING  |                   |
|   | <b>Address</b>  | 1014, 1057,1100  |                   |
|   | <b>Function</b> | Allows reversing the mechanical rotation of the connected motor. |                   |



**DANGER!!!**

When activating **C014 (C057, C100)**, the mechanical rotation of the connected motor and its load is reversed accordingly.

**C015 (C058, C101) Rated Motor Frequency**

|   |                 |  |                    |
|---|-----------------|--|--------------------|
| <b>C015 (Motor 1)<br/>C058 (Motor 2)<br/>C101 (Motor 3)</b> | <b>Range</b>    | 10 ÷ 10000   | 1.0 Hz ÷ 1000.0 Hz |
|   |                 | See upper limits in Table 69   |                    |
|   | <b>Default</b>  | 500  | 50.0 Hz            |
|   | <b>Level</b>    | BASIC  |                    |
|   | <b>Address</b>  | 1015, 1058, 1101   |                    |
|   | <b>Control</b>  | All  |                    |
|   | <b>Function</b> | This parameter defines the rated motor frequency (nameplate rating). |                    |

**C016 (C059, C102) Rated Motor Rpm**

|   |                 |  |               |
|---|-----------------|--|---------------|
| <b>C016 (Motor 1)<br/>C059 (Motor 2)<br/>C102 (Motor 3)</b> | <b>Range</b>    | 1 ÷ 32000  | 1 ÷ 32000 rpm |
|   |                 |  |               |
|   | <b>Default</b>  | 1420   | 1420 rpm      |
|   | <b>Level</b>    | BASIC  |               |
|   | <b>Address</b>  | 1016 , 1059, 1102  |               |
|   | <b>Function</b> | This parameter defines the rated motor rpm (nameplate rating). |               |

**C017 (C060,C103) Rated Motor Power**

|   |                 |  |                 |
|---|-----------------|--|-----------------|
| <b>C017 (Motor 1)<br/>C060 (Motor 2)<br/>C103 (Motor 3)</b> | <b>Range</b>    | 1 ÷ 32000  | 0.1 ÷ 3200.0 kW |
|   |                 | Upper limited to twice the default value                         |                 |
|   | <b>Default</b>  | See Table 82 and Table 86  |                 |
|   | <b>Level</b>    | BASIC  |                 |
|   | <b>Address</b>  | 1017, 1060, 1103   |                 |
|   | <b>Function</b> | This parameter defines the rated motor power (nameplate rating). |                 |

**C018 (C061, C104) Rated Motor Current**

|   |                 |   |                |
|---|-----------------|---|----------------|
| <b>C018 (Motor 1)<br/>C061 (Motor 2)<br/>C104 (Motor 3)</b> | <b>Range</b>    | 1 ÷ 32000   | 0.1 ÷ 3200.0 A |
|   |                 | See twice the upper values in <b>Inom</b> column in Table 79 and Table 83 |                |
|   | <b>Default</b>  | See Table 82 and Table 86   |                |
|   | <b>Level</b>    | BASIC   |                |
|   | <b>Address</b>  | 1018 , 1061, 1104   |                |
|   | <b>Function</b> | This parameter defines the rated motor current (nameplate rating).        |                |

**C019 (C062, C105) Rated Motor Voltage**

|   |                 |  |  |
|---|-----------------|--|--|
| <b>C019 (Motor 1)<br/>C062 (Motor 2)<br/>C105 (Motor 3)</b> | <b>Range</b>    | 50 ÷ 12000   | 5.0 ÷ 1200.0 V   |
|   |                 |  |  |
|   | <b>Default</b>  | 2300 for class 2T drives<br>4000 for class 4T drives<br>5750 for class 5T drives<br>6900 for class 6T drives | 230.0V for class 2T drives<br>400.0V for class 4T drives<br>575.0V for class 5T drives<br>690.0V for class 6T drives |
|   | <b>Level</b>    | BASIC  |  |
|   | <b>Address</b>  | 1019 , 1062, 1105  |  |
|   | <b>Function</b> | This parameter defines the rated motor voltage (nameplate rating).   |  |

**C020 (C063, C106) Motor No-Load Power**

|   |                 |   |              |
|---|-----------------|---|--------------|
| <b>C020 (Motor 1)<br/>C063 (Motor 2)<br/>C106 (Motor 3)</b> | <b>Range</b>    | 0 ÷ 1000  | 0.0 ÷ 100.0% |
|   | <b>Default</b>  | 0   | 0.0%         |
|   | <b>Level</b>    | ADVANCED  |              |
|   | <b>Address</b>  | 1020 , 1063, 1106   |              |
|   | <b>Function</b> | This parameter defines the power absorbed by the motor at rated voltage and rated rpm when no load is connected to the motor. |              |

**C021 (C064,C107) Motor No-Load Current**

|   |                 |  |          |
|---|-----------------|--|----------|
| <b>C021 (Motor 1)<br/>C064 (Motor 2)<br/>C107 (Motor 3)</b> | <b>Range</b>    | 1 ÷ 100  | 1 ÷ 100% |
|   | <b>Default</b>  | 0  | 0%       |
|   | <b>Level</b>    | BASIC  |          |
|   | <b>Address</b>  | 1021, 1064, 1107   |          |
|   | <b>Function</b> | This parameter defines the current absorbed by the motor at rated voltage and rated rpm when no load is connected to the motor. It is expressed as a percentage of the motor rated current <b>C018 (C061, C104)</b> . For a proper tuning of the current loops required for FOC control, enter a value other than zero.<br>If the stator resistance is tuned ( <b>I073</b> = [1: Motor Tune]); <b>I074</b> = (0: All no rotation)) and the no load current parameter is zero, a value for a first attempt is assigned to this parameter, depending on power and pole pairs of the connected motor. |          |

**C022 (C065, C108) Motor Stator Resistance**

|   |                 |  |                 |
|---|-----------------|--|-----------------|
| <b>C022 (Motor 1)<br/>C065 (Motor 2)<br/>C108 (Motor 3)</b> | <b>Range</b>    | 0 ÷ 32000  | 0.000 ÷ 32.000Ω |
|   | <b>Default</b>  | See Table 82 and Table 86  |                 |
|   | <b>Level</b>    | ADVANCED   |                 |
|   | <b>Address</b>  | 1022, 1065, 1108   |                 |
|   | <b>Function</b> | This parameter defines stator resistance Rs.<br>If a star connection is used, it matches with the value of the resistance of one phase (half the resistance measured between two terminals); if a delta connection is used, it matches with 1/3 of the resistance of one phase.<br>Autotune is always recommended. |                 |

**C023 (C066, C109) Motor Leakage Inductance**

|   |                 |   |                 |
|---|-----------------|---|-----------------|
| <b>C023 (Motor 1)<br/>C066 (Motor 2)<br/>C109 (Motor 3)</b> | <b>Range</b>    | 0 ÷ 32000   | 0.00 ÷ 320.00mH |
|   | <b>Default</b>  | See Table 82 and Table 86   |                 |
|   | <b>Level</b>    | ADVANCED  |                 |
|   | <b>Address</b>  | 1023, 1066, 1109  |                 |
|   | <b>Function</b> | This parameter defines the global leakage inductance of the connected motor.<br>If a star connection is used, it matches with the value of the inductance of one phase; if a delta connection is used, it matches with 1/3 of the inductance of one phase.<br>Autotune is always recommended. |                 |

**NOTE**

With the Autotuning function, calculate the value of the leakage inductance (**C023**). From the resulting value, manually subtract the value in mH of the output inductance (if any).

**C024 (C067, C110) Mutual Inductance**

|  |          |   |                 |
|--|----------|---|-----------------|
| C024 (Motor 1)<br>C067 (Motor 2)<br>C110 (Motor 3) | Range    | 0 ÷ 65000   | 0.00 ÷ 650.00mH |
|  | Default  | 25000   | 250.00mH        |
|  | Level    | ADVANCED  |                 |
|  | Address  | 1024, 1067, 1110  |                 |
|  | Function | This parameter defines the mutual inductance of the connected motor. The approximate value of the mutual inductance results from no-load current according to the formula below:<br>$M \cong (V_{mot} - R_{stat} \cdot I_o) / (2\pi f_{mot} \cdot I_o)$ |                 |



**NOTE**

Parameter **C024** (mutual inductance) is **automatically calculated** based on the preset no-load current value (**C021**) whenever parameters **I073** and **I074** are set as follows:  
**I073 = [1: Motor Tune]**  
**I074 = [0: All no rotation]**  
 whether current loop tuning is performed or not.

**C025 (C068, C111) Rotor Time Constant**

|  |          |  |              |
|--|----------|--|--------------|
| C025 (Motor 1)<br>C068 (Motor 2)<br>C111 (Motor 3) | Range    | 0 ÷ 5000   | 0 ÷ 5000msec |
|  | Default  | 0  |              |
|  | Level    | ADVANCED   |              |
|  | Address  | 1025, 1068, 1111   |              |
|  | Control  | VTC and FOC  |              |
|  | Function | This parameter defines the rotor time constant of the connected motor. If the rotor time constant is not stated by the motor manufacturer, it can be obtained through the autotune function (see the FIRST STARTUP section and the AUTOTUNE MENU). |              |



**NOTE**

Whenever one of these parameters is written, the drive automatically computes and saves the parameters of PI flux regulator and FOC control: proportional constant for motor 1 **P158** (**P165** for motor 2, **P172** for motor 3) and integral time **P159** (**P166** for motor 2, **P173** for motor 3).

**C026 (C069, C112) Time Constant of Bus Voltage Low-pass Filter**

|  |          |  |                 |
|--|----------|--|-----------------|
| C026 (Motor 1)<br>C069 (Motor 2)<br>C112 (Motor 3) | Range    | 0 ÷ 32000  | 0.0 ÷ 3200.0 ms |
|  | Default  | 0  | 0.0 ms          |
|  | Level    | ENGINEERING  |                 |
|  | Address  | 1026, 1069, 1112   |                 |
|  | Function | This parameter defines the time constant of the low-pass filter of the bus voltage readout. Changing this value can avoid motor oscillations, especially when no load is connected to the motor. |                 |

**C028 (C071, C114) Min. Motor Speed**

|   |                 |  |                        |
|---|-----------------|--|------------------------|
| <b>C028 (Motor 1)</b><br><b>C071 (Motor 2)</b><br><b>C114 (Motor 3)</b> | <b>Range</b>    | -32000 ÷ 32000 (*)   | -32000 ÷ 32000 rpm (*) |
|   | <b>Default</b>  | 0  | 0 rpm                  |
|   | <b>Level</b>    | BASIC  |                        |
|   | <b>Address</b>  | 1028, 1071, 1114   |                        |
|   | <b>Function</b> | <p>This parameter defines the minimum speed of the connected motor. When references forming the global reference are at their min. relative value, the global reference equals the min. speed of the connected motor.</p> <p><i>Example:</i></p> <p>CONTROL METHOD MENU</p> <p><b>C143</b> →[1: REF] Selection of reference 1 source<br/> <b>C144</b> →[2: AIN1] Selection of reference 2 source<br/> <b>C145</b> →[0: Disable] Selection of reference 3 source<br/> <b>C146</b> →[0: Disable] Selection of reference 4 source</p> <p>INPUTS FOR REFERENCES MENU</p> <p><b>P050</b> →[0: ± 10V] Type of reference for REF input<br/> <b>P051</b> →[ - 10V] Value of the min. reference for REF input<br/> <b>P052</b> →[ +10V] Value of the max. reference for REF input<br/> <b>P055</b> →[0: ± 10V] Type of reference for AIN1 input<br/> <b>P056</b> →[ - 5 V] Value of min. reference for AIN1 input<br/> <b>P057</b> →[ +5 V] Value of max. reference for AIN1 input</p> <p>The speed reference is the min. speed set in <b>C028</b> (motor 1) when both REF input and AIN1 input values are lower than or equal to the minimum values set in <b>P051</b> and <b>P056</b> respectively.</p> |                        |



(\*) **NOTE**

The maximum allowable value (as an absolute value) for **C028** and **C029** (min. and max. motor speed) also depends on the preset **max. carrier frequency** (see Table 69). It can be max. 4 times the rated speed of the connected motor.



**NOTE**

The value set as the min. speed is used as the saturation of the global reference; the speed reference will never be lower than the value set as min. speed.



**NOTE**

The min. speed is not respected only when the REV command or the CW/CCW command are sent after setting a value for max. speed exceeding the min. value (**C029**>**C028** for motor 1) and with the max. reference to the drive. The motor rpm will be **-C029 < C028**.

**C029 (C072, C115) Max. Motor Speed**

|   |                 |  |   |
|---|-----------------|--|---|
| <b>C029 (Motor 1)</b><br><b>C072 (Motor 2)</b><br><b>C115 (Motor 3)</b> | <b>Range</b>    | 0 ÷ 32000 (*see note in parameter <b>C028</b> )  | 0 ÷ 32000 rpm (*see note in parameter <b>C028</b> ) |
|   | <b>Default</b>  | 1500   | 1500 rpm  |
|   | <b>Level</b>    | BASIC  |   |
|   | <b>Address</b>  | 1029, 1072, 1115   |   |
|   | <b>Function</b> | This parameter defines the maximum speed of the connected motor. When references forming the global reference are at their max. relative value, the global reference equals the max. speed of the connected motor.<br>If <b>C011 (C054, C097) = 2: Torque with speed limit</b> , this parameter is used to limit the motor rotation. |   |



**NOTE**

In the CONTROL METHOD MENU, if an external speed/torque limit source (**C147**) is selected, the speed limit value set with this parameter is the upper limit, that can be reduced by adjusting the external source. Also, the ramp times set in the RAMPS MENU (**P009–P025**) are applied to this limit.

**C030 (C073, C116) Flux Weakening Speed**

|   |                 |  |           |
|---|-----------------|--|-----------|
| <b>C030 (Motor 1)</b><br><b>C073 (Motor 2)</b><br><b>C116 (Motor 3)</b> | <b>Range</b>    | 0 ÷ 200  | 0% ÷ 200% |
|   | <b>Default</b>  | 90   | 90%       |
|   | <b>Level</b>    | ENGINEERING  |           |
|   | <b>Address</b>  | 1030, 1073, 1116   |           |
|   | <b>Function</b> | This parameter defines the speed value determining the motor flux weakening. It is expressed as a percentage of the motor rated speed: <b>C016 (C059,C102)</b> |           |

**C031 (C074, C117) Max. Speed Alarm**

|   |                 |  |                           |
|---|-----------------|--|---------------------------|
| <b>C031 (Motor 1)</b><br><b>C074 (Motor 2)</b><br><b>C117 (Motor 3)</b> | <b>Range</b>    | 0 ÷ 32000  | 0: (Disabled) ÷ 32000 rpm |
|   | <b>Default</b>  | 0  | 0: Disabled               |
|   | <b>Level</b>    | ADVANCED   |                           |
|   | <b>Address</b>  | 1031, 1074, 1117   |                           |
|   | <b>Function</b> | If it is not set to zero, this parameter determines the speed value to be entered for the maximum speed alarm ( <b>A076</b> ). |                           |

**C032 (C075, C118) Reduction in Quadratic Torque Curve**

|   |                 |  |            |
|---|-----------------|--|------------|
| <b>C032 (Motor 1)</b><br><b>C075 (Motor 2)</b><br><b>C118 (Motor 3)</b> | <b>Range</b>    | 0 ÷ 1000   | 0 ÷ 100.0% |
|   | <b>Default</b>  | 300  | 30.0%      |
|   | <b>Level</b>    | ADVANCED   |            |
|   | <b>Address</b>  | 1032, 1075, 1118   |            |
|   | <b>Function</b> | If the V/f curve pattern <b>C013 (C056, C099) = Quadratic</b> , this parameter defines the maximum voltage reduction in terms of theoretical V/f pattern, which is implemented at the frequency programmed in <b>C033 (C076, C119)</b> . |            |

**C033 (C076, C119) Max. Reduction Frequency for Quadratic Torque Pattern**

|   |                 |   |          |
|---|-----------------|---|----------|
| <b>C033 (Motor 1)<br/>C076 (Motor 2)<br/>C119 (Motor 3)</b> | <b>Range</b>    | 1 ÷ 100   | 1 ÷ 100% |
|   | <b>Default</b>  | 20  | 20%      |
|   | <b>Level</b>    | ADVANCED  |          |
|   | <b>Address</b>  | 1033, 1076, 1119  |          |
|   | <b>Control</b>  | IFD   |          |
|   | <b>Function</b> | If the V/f curve pattern <b>C013 (C056, C099) = Quadratic</b> , this parameter defines the frequency implementing the max. torque reduction in terms of theoretical V/f pattern set in <b>C032 (C075, C120)</b> . |          |

**C034 (C077, C120) Voltage Preboost for IFD**

|   |                 |   |             |
|---|-----------------|---|-------------|
| <b>C034 (Motor 1)<br/>C077 (Motor 2)<br/>C120 (Motor 3)</b> | <b>Range</b>    | 0 ÷ 50  | 0.0 ÷ 5.0 % |
|   | <b>Default</b>  | See Table 81 and Table 85   |             |
|   | <b>Level</b>    | BASIC   |             |
|   | <b>Address</b>  | 1034, 1077, 1120  |             |
|   | <b>Control</b>  | IFD   |             |
|   | <b>Function</b> | Torque compensation at minimum frequency produced by the drive.<br>IFD control: determines the increase of the output voltage at 0Hz. |             |

**C035 (C078, C121) Voltage Boost 0 at Programmable Frequency**

|   |                 |   |               |
|---|-----------------|---|---------------|
| <b>C035 (Motor 1)<br/>C078 (Motor 2)<br/>C121 (Motor 3)</b> | <b>Range</b>    | -100 ÷ +100   | -100 ÷ +100 % |
|   | <b>Default</b>  | See Table 81 and Table 85   |               |
|   | <b>Level</b>    | ADVANCED  |               |
|   | <b>Address</b>  | 1035, 1078, 1121  |               |
|   | <b>Control</b>  | IFD   |               |
|   | <b>Function</b> | Torque compensation at preset frequency (parameter <b>C035a</b> for motor 1, <b>C078a</b> for motor 2 and <b>C121a</b> for motor 3).<br>This parameter defines the output voltage variation at preset frequency in respect to the frequency resulting from the constant V/f ratio (voltage/frequency constant). It is expressed as a percentage of the nominal motor voltage ( <b>C019, C062, C105</b> ). |               |

**C035a (C078a, C121a) Frequency for Boost 0 Application**

|   |                 |   |          |
|---|-----------------|---|----------|
| <b>C035a (mot. n.1)<br/>C078a (mot. n.2)<br/>C121a (mot. n.3)</b> | <b>Range</b>    | 0 ÷ 99  | 0 ÷ 99 % |
|   | <b>Default</b>  | 5   | 5%       |
|   | <b>Level</b>    | ADVANCED  |          |
|   | <b>Address</b>  | 1052, 1070, 1113  |          |
|   | <b>Control</b>  | IFD   |          |
|   | <b>Function</b> | Frequency for the application of the boost preset with parameter <b>C035</b> for motor 1, <b>C078</b> for motor 2 and <b>C121</b> for motor 3.<br>It is expressed as a percentage of the nominal motor frequency ( <b>C015, C058, C101</b> ). |          |

**C036 (C079, C122) Voltage Boost 1 at Programmable Frequency**

|   |                 |  |               |
|---|-----------------|--|---------------|
| <b>C036 (Motor 1)<br/>C079 (Motor 2)<br/>C122 (Motor 3)</b> | <b>Range</b>    | -100 ÷ +400  | -100 ÷ +400 % |
|   | <b>Default</b>  | See Table 81 and Table 85  |               |
|   | <b>Level</b>    | ADVANCED   |               |
|   | <b>Address</b>  | 1036, 1079, 1122   |               |
|   | <b>Control</b>  | IFD  |               |
|   | <b>Function</b> | Torque compensation at preset frequency (parameter <b>C037</b> for motor 1, <b>C080</b> for motor 2 and <b>C123</b> for motor 3). Determines how output voltage varies at preset frequency with respect to voltage obtained with a constant V/f pattern (constant voltage frequency). It is expressed as a percentage of the nominal motor frequency ( <b>C019, C062, C105</b> ) |               |

**C037 (C080, C123) Frequency for Boost 1 Application**

|   |                 |   |          |
|---|-----------------|---|----------|
| <b>C037 (Motor 1)<br/>C080 (Motor 2)<br/>C123 (Motor 3)</b> | <b>Range</b>    | 6 ÷ 99  | 6 ÷ 99 % |
|   | <b>Default</b>  | See Table 81 and Table 85   |          |
|   | <b>Level</b>    | ADVANCED  |          |
|   | <b>Address</b>  | 1037, 1080, 1123  |          |
|   | <b>Control</b>  | IFD   |          |
|   | <b>Function</b> | Frequency for application of voltage Boost with parameter <b>C036</b> for motor 1, parameter <b>C079</b> for motor 2 and parameter <b>C122</b> for motor 3. This is expressed as a percentage of the motor rated frequency ( <b>C015, C058, C101</b> ). |          |

**C038 (C081, C124) Autoboot**

|   |                 |   |          |
|---|-----------------|---|----------|
| <b>C038 (Motor 1)<br/>C081 (Motor 2)<br/>C124 (Motor 3)</b> | <b>Range</b>    | 0 ÷ 10  | 0 ÷ 10 % |
|   | <b>Default</b>  | See Table 81 and Table 85   |          |
|   | <b>Level</b>    | ADVANCED  |          |
|   | <b>Address</b>  | 1038, 1081, 1124  |          |
|   | <b>Control</b>  | IFD   |          |
|   | <b>Function</b> | Variable torque compensation expressed as a percentage of the motor rated voltage. The preset value expresses the voltage increase when the motor is running at its rated torque. |          |

**C039 (C082, C125) Slip Compensation**

|   |                 |  |                       |
|---|-----------------|--|-----------------------|
| <b>C039 (Motor 1)<br/>C082 (Motor 2)<br/>C125 (Motor 3)</b> | <b>Range</b>    | 0 ÷ 200  | [0: Disabled] ÷ 200 % |
|   | <b>Default</b>  | 0  | [0: Disabled]         |
|   | <b>Level</b>    | ADVANCED   |                       |
|   | <b>Address</b>  | 1039, 1082, 1125   |                       |
|   | <b>Control</b>  | IFD  |                       |
|   | <b>Function</b> | This parameter represents the motor rated slip expressed as a value percent. If set to 0, this function is disabled. |                       |

**C040 (C083, C126) Voltage Drop at Rated Current**

|   |                 |   |            |
|---|-----------------|---|------------|
| <b>C040 (Motor 1)<br/>C083 (Motor 2)<br/>C126 (Motor 3)</b> | <b>Range</b>    | 0÷500   | 0÷50.0%    |
|   | <b>Default</b>  | 0   | 0:Disabled |
|   | <b>Level</b>    | ADVANCED  |            |
|   | <b>Address</b>  | 1040, 1083, 1126  |            |
|   | <b>Control</b>  | IFD   |            |
|   | <b>Function</b> | <p>Defines the voltage increase required to compensate the voltage drop between the inverter and the motor due to the presence of a filter. The voltage increase is given by:<br/> <math>\Delta V = (C040/100) * V_{mot} * I_{out}/I_{mot} * f_{out}/f_{mot}</math>, where <math>I_{out}</math> is the output current, <math>f_{out}</math> is the output frequency, <math>V_{mot}</math>, <math>I_{mot}</math> and <math>f_{mot}</math> are the rated motor voltage, rated motor current and rated motor frequency respectively (parameters <b>C019</b>, <b>C018</b> and <b>C015</b>).</p> <p>Example:<br/> <b>C040 = 10%</b>    Voltage drop at rated current<br/> <b>C013 = Constant Torque</b>                          Type of V/f pattern<br/> <b>C015 = 50 Hz</b>    Rated frequency<br/> <b>C019= 380 V</b>    Rated voltage<br/> <b>C018 = 50 A</b>    Rated current</p> <p>If the drive output frequency is 25 Hz, it should deliver 190V. When the output current is 40A (<b>C018</b>) the voltage actually produced is<br/> <math>V_{out} = 190 + ((10/100 * 380) * 40/50 * 25/50) = 190 + 15.2 = 205.2 V</math>.</p> |            |

**C041 (C084,C127) Fluxing Ramp Time**

|   |                 |  |                |
|---|-----------------|--|----------------|
| <b>C041 (Motor 1)<br/>C084 (Motor 2)<br/>C127 (Motor 3)</b> | <b>Range</b>    | 40 ÷ 4000  | 40 ÷ 4000 msec |
|   | <b>Default</b>  | See Table 80 and Table 84                                  |                |
|   | <b>Level</b>    | ENGINEERING  |                |
|   | <b>Address</b>  | 1041, 1084, 1127   |                |
|   | <b>Control</b>  | VTC and FOC  |                |
|   | <b>Function</b> | This parameter indicates the time spent for motor fluxing. |                |

**C042 (C085, C0128) Vout Saturation Percentage**

|   |                 |   |            |
|---|-----------------|---|------------|
| <b>C042 (Motor 1)<br/>C085 (Motor 2)<br/>C128 (Motor 3)</b> | <b>Range</b>    | 10 ÷ 120  | 10 ÷ 120 % |
|   | <b>Default</b>  | 100   | 100%       |
|   | <b>Level</b>    | ENGINEERING   |            |
|   | <b>Address</b>  | 1042, 1085, 1128  |            |
|   | <b>Function</b> | <p>This parameter sets the bus voltage value percent used to generate the output voltage of the drive.<br/>                     Changes made to this parameter affect the motor performance in terms of flux weakening.</p> |            |

### 34.3. Tables Including the Parameters Depending on the Drive Size

#### 34.3.1. VOLTAGE CLASS 2T/4T

Table 79: Parameters depending on the Drive Size and Model / Class 2T/4T / 1

| SIZE    | MODEL | DRIVE INOM [A] | DRIVE IMAX [A] | DRIVE IPEAK [A] | DEF CARRIER [kHz] |      | DEF Silent Modulation |
|---------|-------|----------------|----------------|-----------------|-------------------|------|-----------------------|
|         |       |                |                |                 | C001              | C002 |                       |
|         |       |                |                |                 | C001              | C001 | C004                  |
|         |       |                |                |                 | C002              | C002 |                       |
| S05     | 0005  | 10.5           | 11.5           | 14              | 5                 | 16   | YES                   |
|         | 0007  | 12.5           | 13.5           | 16              | 5                 | 16   | YES                   |
|         | 0008  | 15             | 16             | 19              | 5                 | 10   | YES                   |
|         | 0009  | 16.5           | 17.5           | 19              | 5                 | 16   | YES                   |
|         | 0010  | 17             | 19             | 23              | 5                 | 10   | YES                   |
|         | 0011  | 16.5           | 21             | 25              | 5                 | 16   | YES                   |
|         | 0013  | 19             | 21             | 25              | 5                 | 10   | YES                   |
|         | 0014  | 16.5           | 25             | 30              | 5                 | 16   | YES                   |
| S05/S12 | 0015  | 23             | 25             | 30              | 5                 | 10   | YES                   |
|         | 0016  | 27             | 30             | 36              | 3/5               | 10   | YES                   |
| S12     | 0020  | 30             | 36             | 43              | 3/5               | 10   | YES                   |
|         | 0017  | 30             | 32             | 37              | 3                 | 10   | YES                   |
|         | 0023  | 38             | 42             | 51              | 3                 | 10   | YES                   |
|         | 0025  | 41             | 48             | 58              | 3                 | 7    | YES                   |
|         | 0030  | 41             | 56             | 67              | 3                 | 7    | YES                   |
|         | 0033  | 51             | 56             | 68              | 3                 | 10   | YES                   |
|         | 0034  | 57             | 63             | 76              | 3                 | 10   | YES                   |
|         | 0036  | 60             | 72             | 86              | 3                 | 10   | YES                   |
| S15     | 0037  | 65             | 72             | 83              | 3                 | 10   | YES                   |
|         | 0040  | 72             | 80             | 88              | 3                 | 16   | YES                   |
| S20     | 0049  | 80             | 96             | 115             | 3                 | 12.8 | YES                   |
|         | 0060  | 88             | 112            | 134             | 3                 | 10   | YES                   |
|         | 0067  | 103            | 118            | 142             | 3                 | 10   | YES                   |
|         | 0074  | 120            | 144            | 173             | 3                 | 10   | YES                   |
| S30     | 0086  | 135            | 155            | 186             | 3                 | 10   | YES                   |
|         | 0113  | 180            | 200            | 240             | 2                 | 10   | YES                   |
|         | 0129  | 195            | 215            | 258             | 2                 | 10   | YES                   |
|         | 0150  | 215            | 270            | 324             | 2                 | 5    | YES                   |
| S41     | 0162  | 240            | 290            | 324             | 2                 | 5    | YES                   |
|         | 0180  | 300            | 340            | 408             | 2                 | 5    | NO                    |
|         | 0202  | 345            | 420            | 504             | 2                 | 5    | NO                    |
|         | 0217  | 375            | 460            | 552             | 2                 | 5    | NO                    |
|         | 0260  | 425            | 560            | 672             | 2                 | 5    | NO                    |

| SIZE  | MODEL | DRIVE<br>INOM<br>[A] | DRIVE<br>IMAX<br>[A] | DRIVE<br>IPEAK<br>[A] | DEF<br>CARRIER<br>[kHz] | MAX<br>CARRIER<br>[kHz] | DEF<br>Silent<br>Modulation |
|-------|-------|----------------------|----------------------|-----------------------|-------------------------|-------------------------|-----------------------------|
|       |       |                      |                      |                       | C001<br>C002            | C001<br>C002            | C004                        |
| S51   | 0313  | 480                  | 600                  | 720                   | 2                       | 5                       | NO                          |
|       | 0367  | 550                  | 680                  | 792                   | 2                       | 5                       | NO                          |
|       | 0402  | 680                  | 850                  | 1020                  | 2                       | 5                       | NO                          |
| S60   | 0457  | 720                  | 880                  | 1056                  | 2                       | 4                       | NO                          |
|       | 0524  | 800                  | 960                  | 1152                  | 2                       | 4                       | NO                          |
| S60P  | 0598P | 900                  | 1100                 | 1320                  | 2                       | 4                       | NO                          |
| S65   | 0598  | 900                  | 1100                 | 1320                  | 2                       | 4                       | NO                          |
|       | 0748  | 1000                 | 1300                 | 1560                  | 2                       | 4                       | NO                          |
|       | 0831  | 1200                 | 1440                 | 1728                  | 2                       | 4                       | NO                          |
| S75   | 0964  | 1480                 | 1780                 | 2136                  | 2                       | 4                       | NO                          |
|       | 1130  | 1700                 | 2040                 | 2448                  | 2                       | 4                       | NO                          |
|       | 1296  | 2100                 | 2520                 | 3024                  | 2                       | 4                       | NO                          |
| S90   | 1800  | 2600                 | 3100                 | 3720                  | 2                       | 4                       | NO                          |
|       | 2076  | 3000                 | 3600                 | 4000                  | 2                       | 4                       | NO                          |
| 2xS41 | 0523  | 765                  | 1000                 | 1200                  | 2                       | 5                       | NO                          |
| 2xS51 | 0599  | 900                  | 1100                 | 1320                  | 2                       | 5                       | NO                          |
|       | 0749  | 1000                 | 1300                 | 1560                  | 2                       | 5                       | NO                          |
|       | 0800  | 1100                 | 1350                 | 1620                  | 2                       | 5                       | NO                          |
|       | 0832  | 1200                 | 1440                 | 1728                  | 2                       | 5                       | NO                          |
| 3xS51 | 0850  | 1340                 | 1600                 | 1920                  | 2                       | 5                       | NO                          |
|       | 0965  | 1480                 | 1780                 | 2136                  | 2                       | 5                       | NO                          |
|       | 1129  | 1650                 | 2000                 | 2400                  | 2                       | 5                       | NO                          |

Table 80: Parameters depending on the Drive Size and Model - Class 2T/4T / 2

| SIZE    | MODEL | DEF TFLUX [ms] | DEF ILIM DEC [%Inom] | DEF DCB RAMP [ms] | DEF Acc. Time [sec] | DEF Dec. Time [sec] | S – Acc/Dec DEF | Fire Mode Ramps DEF [sec] | UNIT Acc. / Dec. DEF [sec] | Dec. Ramp Ext. DEF |
|---------|-------|----------------|----------------------|-------------------|---------------------|---------------------|-----------------|---------------------------|----------------------------|--------------------|
|         | M1    | C041           | C045                 | C222              | P009                | P010                | P022            | P032<br>P033              | P014<br>P020               | C210               |
|         | M2    | C084           | C088                 | C223              | P012                | P013                | P023            |                           |                            |                    |
|         | M3    | C127           | C131                 | C224              | P015<br>P018        | P016<br>P019        | P024<br>P025    |                           |                            |                    |
| S05     | 0005  | 300            | 150                  | 50                | 10                  | 10                  | 50              | 10                        | 0.1                        | 0.2                |
|         | 0007  | 300            | 150                  | 50                | 10                  | 10                  | 50              | 10                        | 0.1                        | 0.2                |
|         | 0008  | 300            | 150                  | 50                | 10                  | 10                  | 50              | 10                        | 0.1                        | 0.2                |
|         | 0009  | 300            | 150                  | 50                | 10                  | 10                  | 50              | 10                        | 0.1                        | 0.2                |
|         | 0010  | 300            | 150                  | 50                | 10                  | 10                  | 50              | 10                        | 0.1                        | 0.2                |
|         | 0011  | 300            | 150                  | 50                | 10                  | 10                  | 50              | 10                        | 0.1                        | 0.2                |
|         | 0013  | 300            | 150                  | 50                | 10                  | 10                  | 50              | 10                        | 0.1                        | 0.2                |
| 0014    | 300   | 150            | 50                   | 10                | 10                  | 50                  | 10              | 0.1                       | 0.2                        |                    |
| 0015    | 300   | 150            | 50                   | 10                | 10                  | 50                  | 10              | 0.1                       | 0.2                        |                    |
| S05/S12 | 0016  | 300            | 150                  | 50                | 10                  | 10                  | 50              | 10                        | 0.1                        | 0.2                |
|         | 0020  | 300            | 150                  | 50                | 10                  | 10                  | 50              | 10                        | 0.1                        | 0.2                |
| S12     | 0017  | 300            | 150                  | 50                | 10                  | 10                  | 50              | 10                        | 0.1                        | 0.2                |
|         | 0023  | 300            | 150                  | 50                | 10                  | 10                  | 50              | 10                        | 0.1                        | 0.2                |
|         | 0025  | 300            | 150                  | 50                | 10                  | 10                  | 50              | 10                        | 0.1                        | 0.2                |
|         | 0030  | 300            | 150                  | 50                | 10                  | 10                  | 50              | 10                        | 0.1                        | 0.2                |
|         | 0033  | 300            | 150                  | 50                | 10                  | 10                  | 50              | 10                        | 0.1                        | 0.2                |
|         | 0034  | 300            | 150                  | 70                | 10                  | 10                  | 50              | 10                        | 0.1                        | 0.2                |
|         | 0036  | 300            | 150                  | 70                | 10                  | 10                  | 50              | 10                        | 0.1                        | 0.2                |
| 0037    | 300   | 150            | 70                   | 10                | 10                  | 50                  | 10              | 0.1                       | 0.2                        |                    |
| S15     | 0040  | 300            | 150                  | 70                | 10                  | 10                  | 50              | 10                        | 0.1                        | 0.2                |
|         | 0049  | 300            | 150                  | 80                | 10                  | 10                  | 50              | 10                        | 0.1                        | 0.2                |
| S20     | 0060  | 300            | 150                  | 80                | 10                  | 10                  | 50              | 10                        | 0.1                        | 0.2                |
|         | 0067  | 300            | 150                  | 100               | 10                  | 10                  | 50              | 10                        | 0.1                        | 0.2                |
|         | 0074  | 300            | 150                  | 100               | 10                  | 10                  | 50              | 10                        | 0.1                        | 0.2                |
|         | 0086  | 300            | 150                  | 150               | 10                  | 10                  | 50              | 10                        | 0.1                        | 0.2                |
| S30     | 0113  | 300            | 150                  | 150               | 10                  | 10                  | 50              | 10                        | 0.1                        | 0.2                |
|         | 0129  | 300            | 150                  | 150               | 10                  | 10                  | 50              | 10                        | 0.1                        | 0.2                |
|         | 0150  | 300            | 150                  | 200               | 10                  | 10                  | 50              | 10                        | 0.1                        | 0.2                |
|         | 0162  | 300            | 150                  | 200               | 10                  | 10                  | 50              | 10                        | 0.1                        | 0.2                |
| S41     | 0180  | 450            | 100                  | 250               | 100                 | 100                 | 1               | 100                       | 1                          | 2                  |
|         | 0202  | 450            | 100                  | 250               | 100                 | 100                 | 1               | 100                       | 1                          | 2                  |
|         | 0217  | 450            | 100                  | 250               | 100                 | 100                 | 1               | 100                       | 1                          | 2                  |
|         | 0260  | 450            | 100                  | 250               | 100                 | 100                 | 1               | 100                       | 1                          | 2                  |

| SIZE  | MODEL | DEF TFLUX [ms] | DEF ILIM DEC [%Inom] | DEF DCB RAMP [ms] | DEF Acc. Time [sec] | DEF Dec. Time [sec] | S – Acc/Dec DEF | Fire Mode Ramps DEF [sec] | UNIT Acc. / Dec. DEF [sec] | Dec. Ramp Ext. DEF |
|-------|-------|----------------|----------------------|-------------------|---------------------|---------------------|-----------------|---------------------------|----------------------------|--------------------|
|       | M1    | C041           | C045                 | C222              | P009                | P010                | P022            | P032<br>P033              | P014<br>P020               | C210               |
|       | M2    | C084           | C088                 | C223              | P012                | P013                | P023            |                           |                            |                    |
|       | M3    | C127           | C131                 | C224              | P015<br>P018        | P016<br>P019        | P024<br>P025    |                           |                            |                    |
| S51   | 0313  | 450            | 100                  | 250               | 100                 | 100                 | 1               | 100                       | 1                          | 2                  |
|       | 0367  | 450            | 100                  | 250               | 100                 | 100                 | 1               | 100                       | 1                          | 2                  |
|       | 0402  | 450            | 100                  | 250               | 100                 | 100                 | 1               | 100                       | 1                          | 2                  |
| S60   | 0457  | 450            | 100                  | 250               | 100                 | 100                 | 1               | 100                       | 1                          | 2                  |
|       | 0524  | 450            | 100                  | 250               | 100                 | 100                 | 1               | 100                       | 1                          | 2                  |
| S60P  | 0598P | 450            | 100                  | 250               | 100                 | 100                 | 1               | 100                       | 1                          | 2                  |
| S65   | 0598  | 450            | 100                  | 250               | 100                 | 100                 | 1               | 100                       | 1                          | 2                  |
|       | 0748  | 450            | 100                  | 250               | 100                 | 100                 | 1               | 100                       | 1                          | 2                  |
|       | 0831  | 450            | 100                  | 250               | 100                 | 100                 | 1               | 100                       | 1                          | 2                  |
| S75   | 0964  | 450            | 100                  | 250               | 100                 | 100                 | 1               | 100                       | 1                          | 2                  |
|       | 1130  | 450            | 100                  | 250               | 100                 | 100                 | 1               | 100                       | 1                          | 2                  |
|       | 1296  | 450            | 100                  | 250               | 100                 | 100                 | 1               | 100                       | 1                          | 2                  |
| S90   | 1800  | 450            | 100                  | 250               | 100                 | 100                 | 1               | 100                       | 1                          | 2                  |
|       | 2076  | 450            | 100                  | 250               | 100                 | 100                 | 1               | 100                       | 1                          | 2                  |
| 2xS41 | 0523  | 450            | 100                  | 250               | 100                 | 100                 | 1               | 100                       | 1                          | 2                  |
| 2xS51 | 0599  | 450            | 100                  | 250               | 100                 | 100                 | 1               | 100                       | 1                          | 2                  |
|       | 0749  | 450            | 100                  | 250               | 100                 | 100                 | 1               | 100                       | 1                          | 2                  |
|       | 0800  | 450            | 100                  | 250               | 100                 | 100                 | 1               | 100                       | 1                          | 2                  |
|       | 0832  | 450            | 100                  | 250               | 100                 | 100                 | 1               | 100                       | 1                          | 2                  |
| 3xS51 | 0850  | 450            | 100                  | 250               | 100                 | 100                 | 1               | 100                       | 1                          | 2                  |
|       | 0965  | 450            | 100                  | 250               | 100                 | 100                 | 1               | 100                       | 1                          | 2                  |
|       | 1129  | 450            | 100                  | 250               | 100                 | 100                 | 1               | 100                       | 1                          | 2                  |

Table 81: Parameters depending on the Drive Size and Model - Class 2T/4T / 3

| SIZE    | MODEL | DEF V/f Pattern | DEF PREBOOST [%Vmot] | BOOST @ 5% fmot and BOOST DEF [%Vmot] | Frequency for BOOST DEF [%fmot] | DEF Auto BOOST [%Vmot] |
|---------|-------|-----------------|----------------------|---------------------------------------|---------------------------------|------------------------|
|         | M1    | C013            | C034                 | C035/C036                             | C037                            | C038                   |
|         | M2    | C056            | C077                 | C078/C079                             | C080                            | C081                   |
|         | M3    | C099            | C120                 | C121/C122                             | C123                            | C124                   |
| S05     | 0005  | 0:CONST         | 1.0                  | 0                                     | 50                              | 1                      |
|         | 0007  | 0:CONST         | 1.0                  | 0                                     | 50                              | 1                      |
|         | 0008  | 0:CONST         | 1.0                  | 0                                     | 50                              | 1                      |
|         | 0009  | 0:CONST         | 1.0                  | 0                                     | 50                              | 1                      |
|         | 0010  | 0:CONST         | 1.0                  | 0                                     | 50                              | 1                      |
|         | 0011  | 0:CONST         | 1.0                  | 0                                     | 50                              | 1                      |
|         | 0013  | 0:CONST         | 1.0                  | 0                                     | 50                              | 1                      |
|         | 0014  | 0:CONST         | 1.0                  | 0                                     | 50                              | 1                      |
| S05/S12 | 0015  | 0:CONST         | 1.0                  | 0                                     | 50                              | 1                      |
|         | 0016  | 0:CONST         | 1.0                  | 0                                     | 50                              | 1                      |
| S12     | 0020  | 0:CONST         | 1.0                  | 0                                     | 50                              | 1                      |
|         | 0017  | 0:CONST         | 1.0                  | 0                                     | 50                              | 1                      |
|         | 0023  | 0:CONST         | 1.0                  | 0                                     | 50                              | 1                      |
|         | 0025  | 0:CONST         | 1.0                  | 0                                     | 50                              | 1                      |
|         | 0030  | 0:CONST         | 1.0                  | 0                                     | 50                              | 1                      |
|         | 0033  | 0:CONST         | 1.0                  | 0                                     | 50                              | 1                      |
|         | 0034  | 0:CONST         | 1.0                  | 0                                     | 50                              | 1                      |
|         | 0036  | 0:CONST         | 1.0                  | 0                                     | 50                              | 1                      |
| S15     | 0037  | 0:CONST         | 1.0                  | 0                                     | 50                              | 1                      |
|         | 0040  | 0:CONST         | 1.0                  | 0                                     | 50                              | 1                      |
| S20     | 0049  | 0:CONST         | 1.0                  | 0                                     | 50                              | 1                      |
|         | 0060  | 0:CONST         | 1.0                  | 0                                     | 50                              | 1                      |
|         | 0067  | 0:CONST         | 1.0                  | 0                                     | 50                              | 1                      |
|         | 0074  | 0:CONST         | 1.0                  | 0                                     | 50                              | 1                      |
| S30     | 0086  | 0:CONST         | 1.0                  | 0                                     | 50                              | 1                      |
|         | 0113  | 0:CONST         | 0.5                  | 0                                     | 50                              | 1                      |
|         | 0129  | 0:CONST         | 0.5                  | 0                                     | 50                              | 1                      |
|         | 0150  | 0:CONST         | 0.5                  | 0                                     | 50                              | 1                      |
| S41     | 0162  | 0:CONST         | 0.5                  | 0                                     | 50                              | 1                      |
|         | 0180  | 2:FREE          | 0.2                  | -20                                   | 20                              | 0                      |
|         | 0202  | 2:FREE          | 0.2                  | -20                                   | 20                              | 0                      |
|         | 0217  | 2:FREE          | 0.2                  | -20                                   | 20                              | 0                      |
|         | 0260  | 2:FREE          | 0.2                  | -20                                   | 20                              | 0                      |

| SIZE         | MODEL     | DEF<br>V/f Pattern | DEF<br>PREBOOST<br>[%Vmot] | BOOST @ 5%<br>fmot and<br>BOOST<br>DEF<br>[%Vmot] | Frequency<br>for BOOST<br>DEF<br>[%fmot] | DEF<br>Auto BOOST<br>[%Vmot] |
|--------------|-----------|--------------------|----------------------------|---|--|------------------------------|
|              | <b>M1</b> | <b>C013</b>        | <b>C034</b>                | <b>C035/C036</b>                                  | <b>C037</b>                              | <b>C038</b>                  |
|              | <b>M2</b> | <b>C056</b>        | <b>C077</b>                | <b>C078/C079</b>                                  | <b>C080</b>                              | <b>C081</b>                  |
|              | <b>M3</b> | <b>C099</b>        | <b>C120</b>                | <b>C121/C122</b>                                  | <b>C123</b>                              | <b>C124</b>                  |
| <b>S51</b>   | 0313      | 2:FREE             | 0.2                        | -20   | 20                                       | 0                            |
|              | 0367      | 2:FREE             | 0.2                        | -20   | 20                                       | 0                            |
|              | 0402      | 2:FREE             | 0.2                        | -20   | 20                                       | 0                            |
| <b>S60</b>   | 0457      | 2:FREE             | 0.2                        | -20   | 20                                       | 0                            |
|              | 0524      | 2:FREE             | 0.2                        | -20   | 20                                       | 0                            |
| <b>S60P</b>  | 0598P     | 2:FREE             | 0.2                        | -20   | 20                                       | 0                            |
| <b>S65</b>   | 0598      | 2:FREE             | 0.2                        | -20   | 20                                       | 0                            |
|              | 0748      | 2:FREE             | 0.2                        | -20   | 20                                       | 0                            |
|              | 0831      | 2:FREE             | 0.2                        | -20   | 20                                       | 0                            |
| <b>S75</b>   | 0964      | 2:FREE             | 0.2                        | -20   | 20                                       | 0                            |
|              | 1130      | 2:FREE             | 0.2                        | -20   | 20                                       | 0                            |
|              | 1296      | 2:FREE             | 0.2                        | -20   | 20                                       | 0                            |
| <b>S90</b>   | 1800      | 2:FREE             | 0.2                        | -20   | 20                                       | 0                            |
|              | 2076      | 2:FREE             | 0.2                        | -20   | 20                                       | 0                            |
| <b>2xS41</b> | 0523      | 2:FREE             | 0.2                        | -20   | 20                                       | 0                            |
| <b>2xS51</b> | 0599      | 2:FREE             | 0.2                        | -20   | 20                                       | 0                            |
|              | 0749      | 2:FREE             | 0.2                        | -20   | 20                                       | 0                            |
|              | 0800      | 2:FREE             | 0.2                        | -20   | 20                                       | 0                            |
|              | 0832      | 2:FREE             | 0.2                        | -20   | 20                                       | 0                            |
| <b>3xS51</b> | 0850      | 2:FREE             | 0.2                        | -20   | 20                                       | 0                            |
|              | 0965      | 2:FREE             | 0.2                        | -20   | 20                                       | 0                            |
|              | 1129      | 2:FREE             | 0.2                        | -20   | 20                                       | 0                            |

Table 82: Parameters depending on the Drive Size and Model - Class 2T/4T /4

| SIZE    | MODEL | 2T            |              |               |                | 4T            |              |               |                |
|---------|-------|---------------|--------------|---------------|----------------|---------------|--------------|---------------|----------------|
|         |       | DEF Pmot [kW] | DEF Imot [A] | DEF Rstat [Ω] | DEF Ldisp [mH] | DEF Pmot [kW] | DEF Imot [A] | DEF Rstat [Ω] | DEF Ldisp [mH] |
|         | M1    | C017          | C018         | C022          | C023           | C017          | C018         | C022          | C023           |
|         | M2    | C060          | C061         | C065          | C066           | C060          | C061         | C065          | C066           |
|         | M3    | C103          | C104         | C108          | C109           | C103          | C104         | C108          | C109           |
| S05     | 0005  | ---           | ---          | ---           | ---            | 3             | 6.4          | 2.500         | 30.00          |
|         | 0007  | 1.8           | 7.3          | 1.155         | 14.43          | 4             | 8.4          | 2.000         | 25.00          |
|         | 0008  | 2.2           | 8.5          | 1.000         | 12.00          | ---           | ---          | ---           | ---            |
|         | 0009  | ---           | ---          | ---           | ---            | 4.5           | 9            | 1.600         | 16.00          |
|         | 0010  | 3             | 11.2         | 0.800         | 7.50           | ---           | ---          | ---           | ---            |
|         | 0011  | ---           | ---          | ---           | ---            | 5.5           | 11.2         | 1.300         | 12.00          |
|         | 0013  | 3.7           | 13.2         | 0.650         | 6.00           | ---           | ---          | ---           | ---            |
|         | 0014  | ---           | ---          | ---           | ---            | 7.5           | 14.8         | 1.000         | 8.00           |
| S05/S12 | 0015  | 4             | 16.6         | 0.600         | 5.00           | ---           | ---          | ---           | ---            |
|         | 0016  | 4.5           | 15.7         | 0.462         | 3.46           | 9.2           | 17.9         | 0.800         | 6.00           |
| S12     | 0020  | 5.5           | 19.5         | 0.346         | 2.89           | 11            | 21.0         | 0.600         | 5.00           |
|         | 0017  | ---           | ---          | ---           | ---            | 9.2           | 21           | 0.800         | 6.00           |
|         | 0023  | 7.5           | 25.7         | 0.300         | 2.50           | ---           | ---          | ---           | ---            |
|         | 0025  | ---           | ---          | ---           | ---            | 15            | 29           | 0.400         | 3.00           |
|         | 0030  | ---           | ---          | ---           | ---            | 18.5          | 35           | 0.300         | 2.50           |
|         | 0033  | 11            | 36           | 0.200         | 1.50           | ---           | ---          | ---           | ---            |
|         | 0034  | ---           | ---          | ---           | ---            | 22            | 41           | 0.250         | 2.00           |
|         | 0036  | ---           | ---          | ---           | ---            | 25            | 46           | 0.250         | 2.00           |
| S15     | 0037  | 15            | 50           | 0.100         | 1.15           | ---           | ---          | ---           | ---            |
|         | 0040  | 15            | 50           | 0.115         | 1.15           | 25            | 46           | 0.200         | 2.00           |
| S20     | 0049  | 18.5          | 61           | 0.087         | 1.15           | 30            | 55           | 0.150         | 2.00           |
|         | 0060  | 22            | 71           | 0.069         | 1.15           | 37            | 67           | 0.120         | 2.00           |
|         | 0067  | 25            | 80           | 0.058         | 0.69           | 45            | 80           | 0.100         | 1.20           |
|         | 0074  | 30            | 96           | 0.046         | 0.69           | 50            | 87           | 0.080         | 1.20           |
| S30     | 0086  | 32            | 103          | 0.035         | 0.58           | 55            | 98           | 0.060         | 1.00           |
|         | 0113  | 45            | 135          | 0.023         | 0.58           | 75            | 133          | 0.040         | 1.00           |
|         | 0129  | 50            | 150          | 0.023         | 0.58           | 80            | 144          | 0.040         | 1.00           |
|         | 0150  | 55            | 170          | 0.017         | 0.58           | 90            | 159          | 0.030         | 1.00           |
| S41     | 0162  | 65            | 195          | 0.012         | 0.58           | 110           | 191          | 0.020         | 1.00           |
|         | 0180  | 75            | 231          | 0.010         | 0.52           | 132           | 228          | 0.018         | 0.9            |
|         | 0202  | 80            | 250          | 0.010         | 0.52           | 160           | 273          | 0.018         | 0.9            |
|         | 0217  | 110           | 332          | 0.009         | 0.46           | 185           | 321          | 0.015         | 0.8            |
|         | 0260  | 110           | 332          | 0.007         | 0.35           | 220           | 375          | 0.012         | 0.6            |

| SIZE  | MODEL | 2T            |              |               |                | 4T            |              |               |                |
|-------|-------|---------------|--------------|---------------|----------------|---------------|--------------|---------------|----------------|
|       |       | DEF Pmot [kW] | DEF Imot [A] | DEF Rstat [Ω] | DEF Ldisp [mH] | DEF Pmot [kW] | DEF Imot [A] | DEF Rstat [Ω] | DEF Ldisp [mH] |
|       | M1    | C017          | C018         | C022          | C023           | C017          | C018         | C022          | C023           |
|       | M2    | C060          | C061         | C065          | C066           | C060          | C061         | C065          | C066           |
|       | M3    | C103          | C104         | C108          | C109           | C103          | C104         | C108          | C109           |
| S51   | 0313  | 132           | 390          | 0.006         | 0.28           | 250           | 375          | 0.012         | 0.50           |
|       | 0367  | 150           | 458          | 0.005         | 0.23           | 280           | 480          | 0.010         | 0.40           |
|       | 0402  | 160           | 475          | 0.005         | 0.17           | 355           | 589          | 0.010         | 0.30           |
| S60   | 0457  | 200           | 593          | 0.005         | 0.14           | 315           | 528          | 0.008         | 0.25           |
|       | 0524  | 220           | 661          | 0.004         | 0.12           | 355           | 589          | 0.007         | 0.20           |
| S60P  | 0598P | 250           | 732          | 0.003         | 0.12           | 400           | 680          | 0.006         | 0.20           |
| S65   | 0598  | 250           | 732          | 0.003         | 0.12           | 400           | 680          | 0.006         | 0.20           |
|       | 0748  | 280           | 840          | 0.002         | 0.09           | 500           | 841          | 0.003         | 0.15           |
|       | 0831  | 330           | 985          | 0.001         | 0.06           | 560           | 939          | 0.002         | 0.10           |
| S75   | 0964  | 400           | 1183         | 0.001         | 0.05           | 710           | 1200         | 0.002         | 0.09           |
|       | 1130  | 450           | 1330         | 0.001         | 0.05           | 800           | 1334         | 0.001         | 0.09           |
|       | 1296  | 560           | 1633         | 0.001         | 0.05           | 1000          | 1650         | 0.001         | 0.09           |
| S90   | 1800  | ---           | ---          | ---           | ---            | 1200          | 2050         | 0.001         | 0.06           |
|       | 2076  | ---           | ---          | ---           | ---            | 1400          | 2400         | 0.001         | 0.05           |
| 2xS41 | 0523  | 220           | 589          | 0.004         | 0.12           | 355           | 589          | 0.007         | 0.20           |
| 2xS51 | 0599  | ---           | ---          | ---           | ---            | 400           | 680          | 0.006         | 0.20           |
|       | 0749  | ---           | ---          | ---           | ---            | 500           | 841          | 0.003         | 0.15           |
|       | 0800  | ---           | ---          | ---           | ---            | 500           | 841          | 0.003         | 0.15           |
|       | 0832  | ---           | ---          | ---           | ---            | 560           | 939          | 0.002         | 0.10           |
| 3xS51 | 0850  | ---           | ---          | ---           | ---            | 630           | 1080         | 0.002         | 0.09           |
|       | 0965  | ---           | ---          | ---           | ---            | 710           | 1200         | 0.002         | 0.09           |
|       | 1129  | ---           | ---          | ---           | ---            | 800           | 1334         | 0.001         | 0.09           |

## 34.3.2. VOLTAGE CLASS 5T/6T

Table 83: Parameters depending on the Drive Size and Model - Class 5T/6T / 1

| SIZE    | MODEL | DRIVE INOM [A] | DRIVE IMAX [A] | DRIVE IPEAK [A] | DEF CARRIER [kHz] | MAX CARRIER [kHz] | DEF Silent Modulation |
|---------|-------|----------------|----------------|-----------------|-------------------|-------------------|-----------------------|
|         |       |                |                |                 | C001<br>C002      | C001<br>C002      | C004                  |
| S12/S14 | 0003  | 7.0            | 8.5            | 10.2            | 3                 | 5                 | YES                   |
|         | 0004  | 9.0            | 11.0           | 13.2            | 3                 | 5                 | YES                   |
|         | 0006  | 11.0           | 13.5           | 16.2            | 3                 | 5                 | YES                   |
|         | 0012  | 13.0           | 16.0           | 19.2            | 3                 | 5                 | YES                   |
|         | 0018  | 17.0           | 21.0           | 25.2            | 3                 | 5                 | YES                   |
| S14     | 0019  | 21             | 25             | 30              | 3                 | 5                 | YES                   |
|         | 0021  | 25             | 30             | 36              | 3                 | 5                 | YES                   |
|         | 0022  | 33             | 40             | 48              | 3                 | 5                 | YES                   |
|         | 0024  | 40             | 48             | 57.6            | 3                 | 5                 | YES                   |
|         | 0032  | 52             | 63             | 75.6            | 3                 | 5                 | YES                   |
| S22     | 0042  | 60             | 72             | 86.4            | 3                 | 5                 | YES                   |
|         | 0051  | 80             | 96             | 115.2           | 3                 | 5                 | YES                   |
|         | 0062  | 85             | 110            | 132             | 3                 | 5                 | YES                   |
|         | 0069  | 105            | 135            | 162             | 3                 | 5                 | YES                   |
| S32     | 0076  | 125            | 165            | 198             | 2                 | 4                 | YES                   |
|         | 0088  | 150            | 200            | 240             | 2                 | 4                 | YES                   |
|         | 0131  | 190            | 250            | 300             | 2                 | 4                 | YES                   |
|         | 0164  | 230            | 300            | 360             | 2                 | 4                 | YES                   |
|         | 0172  | 265            | 345            | 414             | 2                 | 4                 | YES                   |
| S42     | 0181  | 305            | 380            | 455             | 2                 | 4                 | NO                    |
|         | 0201  | 330            | 420            | 504             | 2                 | 4                 | NO                    |
|         | 0218  | 360            | 465            | 558             | 2                 | 4                 | NO                    |
|         | 0259  | 400            | 560            | 672             | 2                 | 4                 | NO                    |
| S52     | 0290  | 450            | 600            | 720             | 2                 | 4                 | NO                    |
|         | 0314  | 500            | 665            | 798             | 2                 | 4                 | NO                    |
|         | 0368  | 560            | 720            | 864             | 2                 | 4                 | NO                    |
|         | 0401  | 640            | 850            | 1020            | 2                 | 4                 | NO                    |
| S65     | 0457  | 720            | 880            | 1056            | 2                 | 2                 | NO                    |
|         | 0524  | 800            | 960            | 1152            | 2                 | 2                 | NO                    |
|         | 0598  | 900            | 1100           | 1320            | 2                 | 2                 | NO                    |
|         | 0748  | 1000           | 1300           | 1440            | 2                 | 2                 | NO                    |
| S70     | 0831  | 1200           | 1440           | 1440            | 2                 | 2                 | NO                    |
| S75     | 0964  | 1480           | 1780           | 2136            | 2                 | 2                 | NO                    |
|         | 1130  | 1700           | 2040           | 2448            | 2                 | 2                 | NO                    |
| S80     | 1296  | 2100           | 2520           | 2520            | 2                 | 2                 | NO                    |
| S90     | 1800  | 2600           | 3100           | 3600            | 2                 | 2                 | NO                    |
|         | 2076  | 3000           | 3600           | 3600            | 2                 | 2                 | NO                    |
| 2xS42   | 0459  | 720            | 1000           | 1200            | 2                 | 4                 | NO                    |
| 2xS52   | 0526  | 800            | 1050           | 1260            | 2                 | 4                 | NO                    |
|         | 0600  | 900            | 1160           | 1392            | 2                 | 4                 | NO                    |
|         | 0750  | 1000           | 1300           | 1560            | 2                 | 4                 | NO                    |
|         | 0828  | 1150           | 1440           | 1728            | 2                 | 4                 | NO                    |
| 3xS52   | 0960  | 1400           | 1800           | 2160            | 2                 | 4                 | NO                    |
|         | 1128  | 1600           | 2040           | 2448            | 2                 | 4                 | NO                    |

Table 84: Parameters depending on the Drive Size and Model - Class 5T/6T / 2

| SIZE    | MODEL | DEF TFLUX [ms] | DEF ILIM DEC [%Inom] | DEF DCB RAMP [ms] | DEF Acc. Time [sec] | DEF Dec. Time [sec] | S – Acc/Dec DEF | Fire Mode Ramp s DEF [sec] | Unit Of Meas. Acc. / Dec. DEF [sec] | Dec. Ramp Ext. DEF |
|---------|-------|----------------|----------------------|-------------------|---------------------|---------------------|-----------------|----------------------------|-------------------------------------|--------------------|
|         | M1    | C041           | C045                 | C222              | P009                | P010                | P022            | P032<br>P033               | P014<br>P020                        | C210               |
|         | M2    | C084           | C088                 | C223              | P012                | P013                | P023            |                            |                                     |                    |
|         | M3    | C127           | C131                 | C224              | P015<br>P018        | P016<br>P019        | P024<br>P025    |                            |                                     |                    |
| S12/S14 | 0003  | 300            | 150                  | 50                | 10                  | 10                  | 50              | 10                         | 0.1                                 | 0.2                |
|         | 0004  | 300            | 150                  | 50                | 10                  | 10                  | 50              | 10                         | 0.1                                 | 0.2                |
|         | 0006  | 300            | 150                  | 50                | 10                  | 10                  | 50              | 10                         | 0.1                                 | 0.2                |
|         | 0012  | 300            | 150                  | 50                | 10                  | 10                  | 50              | 10                         | 0.1                                 | 0.2                |
|         | 0018  | 300            | 150                  | 50                | 10                  | 10                  | 50              | 10                         | 0.1                                 | 0.2                |
| S14     | 0019  | 300            | 150                  | 50                | 10                  | 10                  | 50              | 10                         | 0.1                                 | 0.2                |
|         | 0021  | 300            | 150                  | 50                | 10                  | 10                  | 50              | 10                         | 0.1                                 | 0.2                |
|         | 0022  | 300            | 150                  | 50                | 10                  | 10                  | 50              | 10                         | 0.1                                 | 0.2                |
|         | 0024  | 300            | 150                  | 50                | 10                  | 10                  | 50              | 10                         | 0.1                                 | 0.2                |
|         | 0032  | 300            | 150                  | 50                | 10                  | 10                  | 50              | 10                         | 0.1                                 | 0.2                |
| S22     | 0042  | 300            | 150                  | 80                | 10                  | 10                  | 50              | 10                         | 0.1                                 | 0.2                |
|         | 0051  | 300            | 150                  | 80                | 10                  | 10                  | 50              | 10                         | 0.1                                 | 0.2                |
|         | 0062  | 300            | 150                  | 80                | 10                  | 10                  | 50              | 10                         | 0.1                                 | 0.2                |
|         | 0069  | 300            | 150                  | 100               | 10                  | 10                  | 50              | 10                         | 0.1                                 | 0.2                |
| S32     | 0076  | 300            | 150                  | 100               | 10                  | 10                  | 50              | 10                         | 0.1                                 | 0.2                |
|         | 0088  | 300            | 150                  | 150               | 10                  | 10                  | 50              | 10                         | 0.1                                 | 0.2                |
|         | 0131  | 300            | 150                  | 150               | 10                  | 10                  | 50              | 10                         | 0.1                                 | 0.2                |
|         | 0164  | 300            | 150                  | 200               | 10                  | 10                  | 50              | 10                         | 0.1                                 | 0.2                |
|         | 0172  | 300            | 150                  | 200               | 10                  | 10                  | 50              | 10                         | 0.1                                 | 0.2                |
| S42     | 0181  | 450            | 100                  | 200               | 100                 | 100                 | 1               | 100                        | 1                                   | 2                  |
|         | 0201  | 450            | 100                  | 220               | 100                 | 100                 | 1               | 100                        | 1                                   | 2                  |
|         | 0218  | 450            | 100                  | 250               | 100                 | 100                 | 1               | 100                        | 1                                   | 2                  |
|         | 0259  | 450            | 100                  | 250               | 100                 | 100                 | 1               | 100                        | 1                                   | 2                  |
| S52     | 0290  | 450            | 100                  | 250               | 100                 | 100                 | 1               | 100                        | 1                                   | 2                  |
|         | 0314  | 450            | 100                  | 250               | 100                 | 100                 | 1               | 100                        | 1                                   | 2                  |
|         | 0368  | 450            | 100                  | 250               | 100                 | 100                 | 1               | 100                        | 1                                   | 2                  |
|         | 0401  | 450            | 100                  | 250               | 100                 | 100                 | 1               | 100                        | 1                                   | 2                  |
| S65     | 0457  | 450            | 100                  | 250               | 100                 | 100                 | 1               | 100                        | 1                                   | 2                  |
|         | 0524  | 450            | 100                  | 250               | 100                 | 100                 | 1               | 100                        | 1                                   | 2                  |
|         | 0598  | 450            | 100                  | 250               | 100                 | 100                 | 1               | 100                        | 1                                   | 2                  |
|         | 0748  | 450            | 100                  | 250               | 100                 | 100                 | 1               | 100                        | 1                                   | 2                  |
| S70     | 0831  | 450            | 100                  | 250               | 100                 | 100                 | 1               | 100                        | 1                                   | 2                  |
| S75     | 0964  | 450            | 100                  | 250               | 100                 | 100                 | 1               | 100                        | 1                                   | 2                  |
|         | 1130  | 450            | 100                  | 250               | 100                 | 100                 | 1               | 100                        | 1                                   | 2                  |
| S80     | 1296  | 450            | 100                  | 250               | 100                 | 100                 | 1               | 100                        | 1                                   | 2                  |
| S90     | 1800  | 450            | 100                  | 250               | 100                 | 100                 | 1               | 100                        | 1                                   | 2                  |
|         | 2076  | 450            | 100                  | 250               | 100                 | 100                 | 1               | 100                        | 1                                   | 2                  |
| 2xS42   | 0459  | 450            | 100                  | 250               | 100                 | 100                 | 1               | 100                        | 1                                   | 2                  |
| 2xS52   | 0526  | 450            | 100                  | 250               | 100                 | 100                 | 1               | 100                        | 1                                   | 2                  |
|         | 0600  | 450            | 100                  | 250               | 100                 | 100                 | 1               | 100                        | 1                                   | 2                  |
|         | 0750  | 450            | 100                  | 250               | 100                 | 100                 | 1               | 100                        | 1                                   | 2                  |
|         | 0828  | 450            | 100                  | 250               | 100                 | 100                 | 1               | 100                        | 1                                   | 2                  |
| 3xS52   | 0960  | 450            | 100                  | 250               | 100                 | 100                 | 1               | 100                        | 1                                   | 2                  |
|         | 1128  | 450            | 100                  | 250               | 100                 | 100                 | 1               | 100                        | 1                                   | 2                  |

Table 85: Parameters depending on the Drive Size and Model - Class 5T/6T / 3

| SIZE    | MODEL | DEF V/f Pattern | DEF PREBOOST [%Vmot] | BOOST @ 5% fmot and BOOST DEF [%Vmot] | Frequency for BOOST DEF [%fmot] | DEF Auto BOOST [%Vmot] |
|---------|-------|-----------------|----------------------|---------------------------------------|---------------------------------|------------------------|
|         | M1    | C013            | C034                 | C035/C036                             | C037                            | C038                   |
|         | M2    | C056            | C077                 | C078/C079                             | C080                            | C081                   |
|         | M3    | C099            | C120                 | C121/C122                             | C123                            | C124                   |
| S12/S14 | 0003  | 0:CONST         | 1.0                  | 0                                     | 50                              | 1                      |
|         | 0004  | 0:CONST         | 1.0                  | 0                                     | 50                              | 1                      |
|         | 0006  | 0:CONST         | 1.0                  | 0                                     | 50                              | 1                      |
|         | 0012  | 0:CONST         | 1.0                  | 0                                     | 50                              | 1                      |
|         | 0018  | 0:CONST         | 1.0                  | 0                                     | 50                              | 1                      |
| S14     | 0019  | 0:CONST         | 1.0                  | 0                                     | 50                              | 1                      |
|         | 0021  | 0:CONST         | 1.0                  | 0                                     | 50                              | 1                      |
|         | 0022  | 0:CONST         | 1.0                  | 0                                     | 50                              | 1                      |
|         | 0024  | 0:CONST         | 1.0                  | 0                                     | 50                              | 1                      |
|         | 0032  | 0:CONST         | 1.0                  | 0                                     | 50                              | 1                      |
| S22     | 0042  | 0:CONST         | 1.0                  | 0                                     | 50                              | 1                      |
|         | 0051  | 0:CONST         | 1.0                  | 0                                     | 50                              | 1                      |
|         | 0062  | 0:CONST         | 1.0                  | 0                                     | 50                              | 1                      |
|         | 0069  | 0:CONST         | 1.0                  | 0                                     | 50                              | 1                      |
| S32     | 0076  | 0:CONST         | 1.0                  | 0                                     | 50                              | 1                      |
|         | 0088  | 0:CONST         | 1.0                  | 0                                     | 50                              | 1                      |
|         | 0131  | 0:CONST         | 0.5                  | 0                                     | 50                              | 1                      |
|         | 0164  | 0:CONST         | 0.5                  | 0                                     | 50                              | 1                      |
|         | 0172  | 0:CONST         | 0.5                  | 0                                     | 50                              | 1                      |
| S42     | 0181  | 2:FREE          | 0.2                  | -20                                   | 20                              | 0                      |
|         | 0201  | 2:FREE          | 0.2                  | -20                                   | 20                              | 0                      |
|         | 0218  | 2:FREE          | 0.2                  | -20                                   | 20                              | 0                      |
|         | 0259  | 2:FREE          | 0.2                  | -20                                   | 20                              | 0                      |
| S52     | 0290  | 2:FREE          | 0.2                  | -20                                   | 20                              | 0                      |
|         | 0314  | 2:FREE          | 0.2                  | -20                                   | 20                              | 0                      |
|         | 0368  | 2:FREE          | 0.2                  | -20                                   | 20                              | 0                      |
|         | 0401  | 2:FREE          | 0.2                  | -20                                   | 20                              | 0                      |
| S65     | 0457  | 2:FREE          | 0.2                  | -20                                   | 20                              | 0                      |
|         | 0524  | 2:FREE          | 0.2                  | -20                                   | 20                              | 0                      |
|         | 0598  | 2:FREE          | 0.2                  | -20                                   | 20                              | 0                      |
|         | 0748  | 2:FREE          | 0.2                  | -20                                   | 20                              | 0                      |
| S70     | 0831  | 2:FREE          | 0.2                  | -20                                   | 20                              | 0                      |
| S75     | 0964  | 2:FREE          | 0.2                  | -20                                   | 20                              | 0                      |
|         | 1130  | 2:FREE          | 0.2                  | -20                                   | 20                              | 0                      |
| S80     | 1296  | 2:FREE          | 0.2                  | -20                                   | 20                              | 0                      |
| S90     | 1800  | 2:FREE          | 0.2                  | -20                                   | 20                              | 0                      |
|         | 2076  | 2:FREE          | 0.2                  | -20                                   | 20                              | 0                      |
| 2xS42   | 0459  | 2:FREE          | 0.2                  | -20                                   | 20                              | 0                      |
| 2xS52   | 0526  | 2:FREE          | 0.2                  | -20                                   | 20                              | 0                      |
|         | 0600  | 2:FREE          | 0.2                  | -20                                   | 20                              | 0                      |
|         | 0750  | 2:FREE          | 0.2                  | -20                                   | 20                              | 0                      |
|         | 0828  | 2:FREE          | 0.2                  | -20                                   | 20                              | 0                      |
| 3xS52   | 0960  | 2:FREE          | 0.2                  | -20                                   | 20                              | 0                      |
|         | 1128  | 2:FREE          | 0.2                  | -20                                   | 20                              | 0                      |

Table 86: Parameters depending on the Drive Size and Model - Class 5T/6T / 4

| SIZE    | MODEL | 5T            |              |               |                | 6T            |              |               |                |
|---------|-------|---------------|--------------|---------------|----------------|---------------|--------------|---------------|----------------|
|         |       | DEF Pmot [kW] | DEF Imot [A] | DEF Rstat [Ω] | DEF Ldisp [mH] | DEF Pmot [kW] | DEF Imot [A] | DEF Rstat [Ω] | DEF Ldisp [mH] |
|         | M1    | C017          | C018         | C022          | C023           | C017          | C018         | C022          | C023           |
|         | M2    | C060          | C061         | C065          | C066           | C060          | C061         | C065          | C066           |
|         | M3    | C103          | C104         | C108          | C109           | C103          | C104         | C108          | C109           |
| S12/S14 | 0003  | 3.0           | 4.4          | 3.608         | 43.30          | 4.0           | 4.8          | 4.330         | 51.96          |
|         | 0004  | 4.0           | 5.7          | 3.608         | 43.30          | 4.0           | 4.8          | 4.330         | 51.96          |
|         | 0006  | 5.5           | 7.6          | 2.887         | 36.08          | 7.5           | 8.4          | 3.464         | 43.30          |
|         | 0012  | 7.5           | 10.0         | 1.732         | 15.88          | 7.5           | 8.4          | 2.078         | 19.05          |
|         | 0018  | 9.2           | 12.5         | 1.155         | 8.66           | 11.0          | 12.1         | 1.386         | 10.39          |
| S14     | 0019  | 11.0          | 14.0         | 1.155         | 8.66           | 11.0          | 12.1         | 1.386         | 10.39          |
|         | 0021  | 15.0          | 20.0         | 0.866         | 7.22           | 15.0          | 16.8         | 1.039         | 8.66           |
|         | 0022  | 18.5          | 25.0         | 0.866         | 7.22           | 22.0          | 23.0         | 1.039         | 8.66           |
|         | 0024  | 22.0          | 28.0         | 0.577         | 4.33           | 22.0          | 23.0         | 0.693         | 5.20           |
|         | 0032  | 30.0          | 39.0         | 0.433         | 3.61           | 37.0          | 39.0         | 0.520         | 4.33           |
| S22     | 0042  | 37            | 47           | 0.217         | 2.89           | 37            | 39           | 0.260         | 3.46           |
|         | 0051  | 45            | 55           | 0.173         | 2.89           | 55            | 56           | 0.208         | 3.46           |
|         | 0062  | 55            | 70           | 0.173         | 2.89           | 55            | 55.8         | 0.208         | 3.46           |
|         | 0069  | 55            | 70           | 0.144         | 1.73           | 75            | 78.1         | 0.173         | 2.08           |
| S32     | 0076  | 75            | 95           | 0.115         | 1.73           | 90            | 94.4         | 0.139         | 2.08           |
|         | 0088  | 110           | 135          | 0.087         | 1.44           | 110           | 112.6        | 0.104         | 1.73           |
|         | 0131  | 110           | 135          | 0.058         | 1.44           | 160           | 158          | 0.069         | 1.73           |
|         | 0164  | 132           | 168          | 0.029         | 1.44           | 185           | 185          | 0.035         | 1.73           |
|         | 0172  | 160           | 198          | 0.029         | 1.44           | 200           | 198          | 0.035         | 1.73           |
| S42     | 0181  | 185           | 225          | 0.026         | 1.44           | 220           | 220          | 0.031         | 1.73           |
|         | 0201  | 200           | 240          | 0.026         | 1.30           | 250           | 250          | 0.031         | 1.56           |
|         | 0218  | 220           | 275          | 0.022         | 1.15           | 315           | 310          | 0.026         | 1.39           |
|         | 0259  | 280           | 336          | 0.017         | 0.87           | 355           | 341          | 0.021         | 1.04           |
| S52     | 0290  | 300           | 358          | 0.017         | 0.72           | 400           | 390          | 0.020         | 0.86           |
|         | 0314  | 330           | 395          | 0.017         | 0.72           | 450           | 440          | 0.020         | 0.86           |
|         | 0368  | 355           | 420          | 0.014         | 0.57           | 500           | 480          | 0.017         | 0.69           |
|         | 0401  | 400           | 473          | 0.014         | 0.43           | 560           | 544          | 0.017         | 0.51           |
| S65     | 0457  | 500           | 585          | 0.012         | 0.36           | 560           | 544          | 0.014         | 0.43           |
|         | 0524  | 560           | 630          | 0.010         | 0.29           | 630           | 626          | 0.012         | 0.35           |
|         | 0598  | 630           | 720          | 0.009         | 0.29           | 710           | 696          | 0.010         | 0.35           |
|         | 0748  | 710           | 800          | 0.004         | 0.22           | 900           | 858          | 0.005         | 0.26           |
| S70     | 0831  | 800           | 900          | 0.003         | 0.14           | 1000          | 954          | 0.003         | 0.17           |
| S75     | 0964  | 1000          | 1450         | 0.003         | 0.13           | 1220          | 1187         | 0.003         | 0.16           |
|         | 1130  | 1170          | 1360         | 0.001         | 0.13           | 1400          | 1360         | 0.001         | 0.16           |
| S80     | 1296  | 1340          | 1560         | 0.001         | 0.13           | 1610          | 1560         | 0.001         | 0.16           |
| S90     | 1800  | 1750          | 2050         | 0.001         | 0.08           | 2100          | 2100         | 0.001         | 0.10           |
|         | 2076  | 2000          | 2400         | 0.001         | 0.07           | 2400          | 2400         | 0.001         | 0.08           |
| 2xS42   | 0459  | 500           | 626          | 0.012         | 0.36           | 630           | 626          | 0.014         | 0.43           |
| 2xS52   | 0526  | 500           | 696          | 0.010         | 0.29           | 710           | 696          | 0.012         | 0.35           |
|         | 0600  | 630           | 773          | 0.009         | 0.29           | 800           | 773          | 0.010         | 0.35           |
|         | 0750  | 710           | 800          | 0.004         | 0.22           | 900           | 858          | 0.005         | 0.26           |
|         | 0828  | 710           | 800          | 0.003         | 0.14           | 1000          | 954          | 0.003         | 0.17           |
| 3xS52   | 0960  | 1000          | 1145         | 0.003         | 0.13           | 1200          | 1187         | 0.003         | 0.16           |
|         | 1128  | 1000          | 1360         | 0.001         | 0.13           | 1400          | 1360         | 0.002         | 0.16           |

## 35. LIMITS MENU

### 35.1. Overview

The **Limits Menu** defines the current/torque limits applied to the control functions (IFD, VTC or FOC controls) selected for the three connected motors.

For IFD control, current limits are used. Three limit current levels are available, which are expressed as a percentage of the motor rated current:

- 1) Current limit while accelerating;
- 2) Current limit at constant rpm;
- 3) Current limit while decelerating.

Two special parameters are also available; one sets the decrease of the limit current value when the motor runs at constant power (flux weakening), while the other parameter disables the frequency decrease in case of acceleration current limit (this is useful for inertial loads).

If a VTC control or a FOC control is used, limits are expressed as a percentage of the rated motor torque.

Values set in the two parameters relating to min. torque and max. torque represent the limits for saturation of the control torque demand. If an external torque limit is set (**C147** in the CONTROL METHOD MENU), the values set in the parameters above represent the range of the source used for limitation; the torque ramp times set in the RAMPS MENU will be applied to the preset limit torque reference.

The  $I_{peak}$  current load is available (see Table 79 and Table 83) for a maximum time of 3 seconds and only if the preset carrier frequency is lower than/equal to the default frequency value (see Table 79 and Table 83). When operating with synchronous modulation, the current peak value dynamically decreases when the output frequency increases.

Manually enabling/disabling that function can be done only when using the IFD control with current limit parameters **C043/C044/C045**. When using the **VTC** or **FOC** control, the system will automatically handle the maximum current value that can be used also based on the torque limit configured with **C047/C048**.

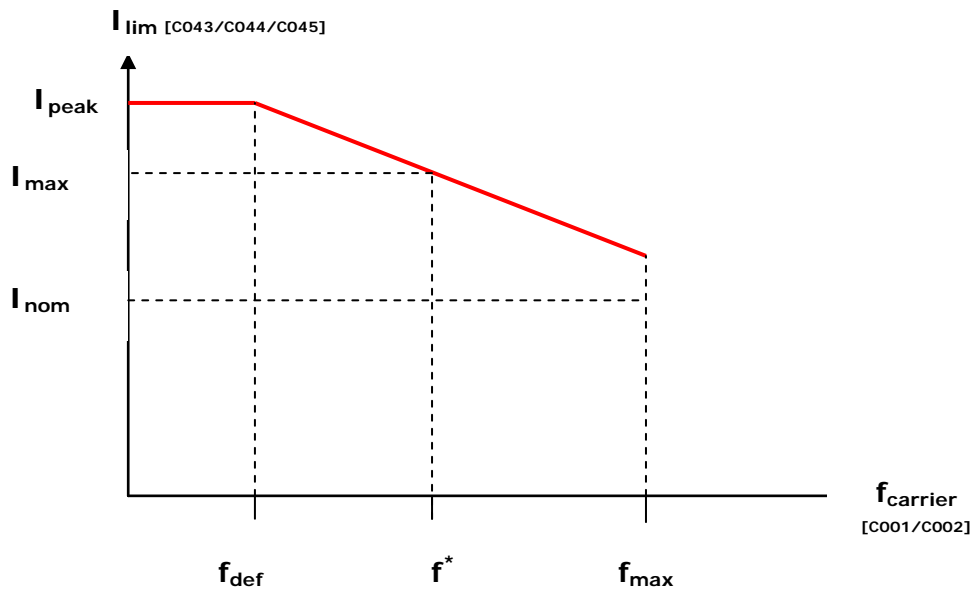

Figure 44: Current limit decreased based on the carrier frequency

$f^*$ : Max. frequency for which  $I_{max}$  can be obtained.

## 35.2. List of Parameters C043 to C135

Table 87: List of parameters C043 to C135

| Parameter |    | FUNCTION                                     | User Level | MODBUS Address | DEFAULT VALUES            |
|-----------|----|--|------------|----------------|---------------------------|
| C043      | M1 | Current limit while accelerating             | BASIC      | 1043           | 150%                      |
| C086      | M2 |  | ADVANCED   | 1086           |                           |
| C129      | M3 |  |            | 1129           |                           |
| C044      | M1 | Current limit at constant rpm                | BASIC      | 1044           | 150%                      |
| C087      | M2 |  | ADVANCED   | 1087           |                           |
| C130      | M3 |  |            | 1130           |                           |
| C045      | M1 | Current limit while decelerating             | BASIC      | 1045           | See Table 80 and Table 84 |
| C088      | M2 |  | ADVANCED   | 1088           |                           |
| C131      | M3 |  |            | 1131           |                           |
| C046      | M1 | Current limit decrease in flux weakening     | ADVANCED   | 1046           | 0: Disabled               |
| C089      | M2 |  |            | 1089           |                           |
| C132      | M3 |  |            | 1132           |                           |
| C047      | M1 | Minimum torque                               | ADVANCED   | 1047           | 0.0%                      |
| C090      | M2 |  |            | 1090           |                           |
| C133      | M3 |  |            | 1133           |                           |
| C048      | M1 | Maximum torque                               | BASIC      | 1048           | 120.0%                    |
| C091      | M2 |  | ADVANCED   | 1091           |                           |
| C134      | M3 |  |            | 1134           |                           |
| C050      | M1 | Frequency decrease during acceleration limit | ADVANCED   | 1050           | 0: Enabled                |
| C093      | M2 |  |            | 1093           |                           |
| C136      | M3 |  |            | 1136           |                           |

**C043 (C086, C129) Current Limit While accelerating**

|   |                 |  |   |
|---|-----------------|--|---|
| <b>C043 (Motor 1)<br/>C086 (Motor 2)<br/>C129 (Motor 3)</b> | <b>Range</b>    | 0 ÷ 400 (*)  | 0: Disabled<br>1.0% ÷ Min[ <i>I<sub>peak inverter</sub>/I<sub>mot</sub>, 400.0%</i> ] |
|   | <b>Default</b>  | 150%   |   |
|   | <b>Level</b>    | BASIC (C043); ADVANCED (C086, C129)  |   |
|   | <b>Address</b>  | 1043, 1086, 1129   |   |
|   | <b>Control</b>  | IFD  |   |
|   | <b>Function</b> | This parameter defines the current limit while accelerating; it is expressed as a percentage of the rated current of the selected motor.<br>No limit is applied if this parameter is set to 0: Disabled. |   |

(\*) The maximum allowable value depends on the drive size.

**C044 (C087, C130) Current Limit at Constant Rpm**

|   |                 |   |   |
|---|-----------------|---|---|
| <b>C044 (Motor 1)<br/>C087 (Motor 2)<br/>C130 (Motor 3)</b> | <b>Range</b>    | 0 ÷ 400 (*)   | 0: Disabled<br>1.0% ÷ Min[ <i>I<sub>peak inverter</sub>/I<sub>mot</sub>, 400.0%</i> ] |
|   | <b>Default</b>  | 150%  |   |
|   | <b>Level</b>    | BASIC (C044); ADVANCED (C087, C130)   |   |
|   | <b>Address</b>  | 1044, 1087, 1130  |   |
|   | <b>Control</b>  | IFD   |   |
|   | <b>Function</b> | This parameter defines the current limit at constant rpm; it is expressed as a percentage of the rated current of the selected motor.<br>No limit is applied if this parameter is set to 0: Disabled. |   |

(\*) The maximum allowable value depends on the drive size.

**C045 (C088, C131) Current Limit while Decelerating**

|   |                 |  |   |
|---|-----------------|--|---|
| <b>C045 (Motor 1)<br/>C088 (Motor 2)<br/>C131 (Motor 3)</b> | <b>Range</b>    | 0 ÷ 400 (*)  | 0: Disabled<br>1.0% ÷ Min[ <i>I<sub>peak inverter</sub>/I<sub>mot</sub>, 400.0%</i> ] |
|   | <b>Default</b>  | See Table 80 and Table 84  |   |
|   | <b>Level</b>    | BASIC (C045); ADVANCED (C088, C131)  |   |
|   | <b>Address</b>  | 1045, 1088, 1131   |   |
|   | <b>Control</b>  | IFD  |   |
|   | <b>Function</b> | This parameter defines the current limit while decelerating; it is expressed as a percentage of the rated current of the selected motor.<br>No limit is applied if this parameter is set to 0: Disabled. |   |

(\*) The maximum allowable value depends on the drive size.

**C046 (C089, C132) Current Limit Decrease in Flux Weakening**

|   |                 |   |                           |
|---|-----------------|---|---------------------------|
| <b>C046 (Motor 1)<br/>C089 (Motor 2)<br/>C132 (Motor 3)</b> | <b>Range</b>    | 0 ÷ 1   | 0: Disabled<br>1: Enabled |
|   | <b>Default</b>  | 0   | 0: Disabled               |
|   | <b>Level</b>    | ADVANCED  |                           |
|   | <b>Address</b>  | 1046, 1089, 1132  |                           |
|   | <b>Control</b>  | IFD   |                           |
|   | <b>Function</b> | This parameter enables the current limit decrease function in flux weakening.<br>The current limit is multiplied by the ratio between the motor rated torque and the frequency forced to the drive:<br><br>limit = current limit being used * (F <sub>mot</sub> / F <sub>out</sub> ). |                           |

**C047 (C090, C133) Minimum Torque**

|   |                 |  |                   |
|---|-----------------|--|-------------------|
| <b>C047 (Motor 1)</b><br><b>C090 (Motor 2)</b><br><b>C133 (Motor 3)</b> | <b>Range</b>    | -5000 ÷ 5000 (*)   | -500.0% ÷ +500.0% |
|   | <b>Default</b>  | 0  | 0.0%              |
|   | <b>Level</b>    | ADVANCED   |                   |
|   | <b>Address</b>  | 1047, 1090, 1133   |                   |
|   | <b>Control</b>  | VTC and FOC  |                   |
|   | <b>Function</b> | This parameter sets the min. limit of the torque demanded by the control being used.<br>Torque is expressed as a percentage of the rated torque of the selected motor. |                   |



**NOTE**

If an external torque limit is set (**C147** in the CONTROL METHOD MENU), the values set in the parameters above represent the range of the source used for limitation; they can be reduced by adjusting the external source; the torque ramp times set in the RAMPS MENU will be applied to the preset limit torque reference (**P026–P027**).

**C048 (C091, C134) Maximum Torque**

|   |                 |  |                   |
|---|-----------------|--|-------------------|
| <b>C048 (Motor 1)</b><br><b>C091 (Motor 2)</b><br><b>C134 (Motor 3)</b> | <b>Range</b>    | -5000(*) ÷ 5000 (*)  | -500.0% ÷ +500.0% |
|   | <b>Default</b>  | 1200   | 120.0%            |
|   | <b>Level</b>    | BASIC (C048); ADVANCED (C091;C134)   |                   |
|   | <b>Address</b>  | 1048, 1091, 1134   |                   |
|   | <b>Control</b>  | VTC and FOC  |                   |
|   | <b>Function</b> | This parameter sets the max. limit of the torque demanded by the control being used.<br>Torque is expressed as a percentage of the rated torque of the selected motor. |                   |



**NOTE**

If an external torque limit is set (**C147** in the CONTROL METHOD MENU), the values set in the parameters above represent the range of the source used for limitation; the torque ramp times set in the RAMPS MENU will be applied to the preset limit torque reference (**P026–P027**).

**C050 (C093, C136) Frequency Decrease during Acceleration Limit**

|   |                 |   |                           |
|---|-----------------|---|---------------------------|
| <b>C050 (Motor 1)</b><br><b>C093 (Motor 2)</b><br><b>C136 (Motor 3)</b> | <b>Range</b>    | 0 ÷ 1   | 0: Enabled<br>1: Disabled |
|   | <b>Default</b>  | 0   | 0: Enabled                |
|   | <b>Level</b>    | ADVANCED  |                           |
|   | <b>Address</b>  | 1050, 1093, 1136  |                           |
|   | <b>Control</b>  | IFD   |                           |
|   | <b>Function</b> | This parameter enables output frequency decrease during acceleration limit. |                           |



**NOTE**

Setting “1:Disabled” is recommended for high inertia loads. When high inertia loads are connected to the drive, the frequency decrease can lead to strong regeneration and DC-bus voltage oscillations.

## 36. CONTROL METHOD MENU

### 36.1. Overview

---

**NOTE**

Please refer to the Sinus Penta's Installation Guide for the hardware description of digital inputs (COMMANDS) and analog inputs (REFERENCES).  
See also the INPUTS FOR REFERENCES MENU and the DIGITAL INPUTS MENU.

The drive is factory set to receive digital commands via the terminal board; the main speed reference is sent from the REF analog input, and no external limit for torque limitation is enabled.

The parameters in this menu allow selecting the following:

- The source of the **drive commands** (digital inputs) from **three signal sources** (through parameters **C140**, **C141**, **C142**) which are logically matched so as to obtain an active **M031** command set. For each of these 3 **parameters** you can select the source of the command signals from **4 different sources**;

- The source of the **speed reference** (or torque reference) from **4 different sources** (that can be selected with parameters **C143**, **C144**, **C145**, **C146**) that **can be summed up together**.

For each of these **4 parameters**, you can select the source of the reference signals from **9 different sources**;

- The source of the **torque limit** reference (through parameter **C147**, allowing selecting the reference source from **9 different sources**).

Therefore, you can select and enable different **command sources** (hardware or virtual sources), different speed (or torque) **references** (hardware or virtual sources) and enable an external torque **limit**.

The drive **commands** may be sent from:

- The hardware terminal board (terminal board on the control board), which is logically separated into terminal board A and terminal board B;
- The keypad;
- The virtual remote terminal board: through serial link with MODBUS communications protocol;
- The virtual remote terminal board: through Fieldbus (optional board).

Multiple terminal boards may also be enabled (up to 3 terminal boards with parameters **C140**, **C141**, **C142**); in this case, the drive will apply logic functions **OR** or **AND** to the different terminals to obtain the activated terminal board (see Command Sources).

The following **references** and torque limit signals may be sent:

- Three analog inputs acquired to the hardware terminal board (REF, AIN1, AIN2), plus two analog inputs (XAIN4, XAIN5) acquired to the hardware terminal board located on ES847 optional board;
- FIN frequency input;
- Encoder input;
- Keypad;
- Serial link with MODBUS communications protocol;
- Fieldbus (optional board);
- Up/Down from MDI (Up and Down digital inputs).

Multiple reference sources may be enabled at the same time (up to 4 reference sources with parameters **C143**, **C144**, **C145**, **C146**); in this case, the drive will consider the sum of all active reference as the main reference.

Finally, a dynamic selection between two command sources and two reference sources is allowed when using the digital input configured as Source Selection (see **C179**).

### 36.1.1. COMMAND SOURCES

The **drive commands** may be sent from the following sources:

- 0: Disabled
- 1: Terminal board A
- 2: Serial link (with MODBUS protocol)
- 3: Fieldbus (fieldbus on optional board)
- 4: Terminal board B
- 5: Keypad (removable display/keypad)

The factory-setting enables only Terminal Board A (**C140=1** and **C141=1**) as a command source (see also the DIGITAL INPUTS MENU). Both Terminal board A and B refer to the same terminal board located on the control board, but allow switching between one set of START, STOP, REVERSE commands sent to three terminals to a different set of commands sent to three different terminals.

Most commands may be delayed (when enabled or disabled): refer to the TIMERS MENU.

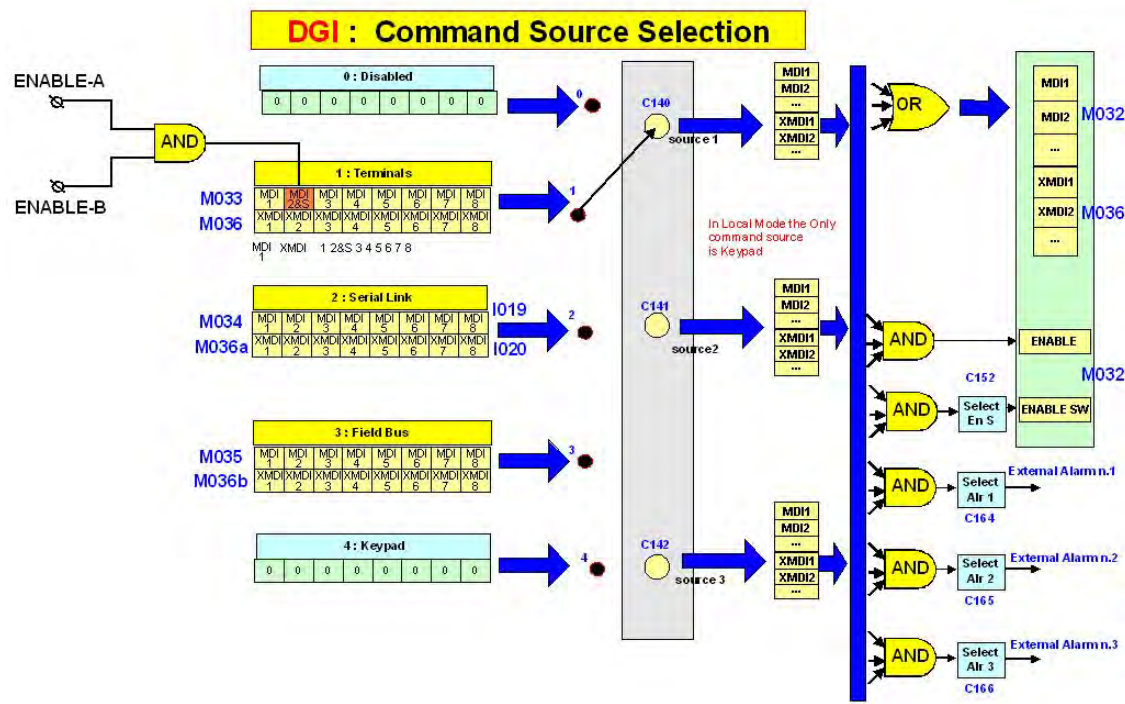

Figure 45: Selecting the command sources

If the keypad is not selected as a command source or if the **STOP** input function is enabled (**C150≠0**), more than one command source may be enabled at a time. In this case, the logic function implemented by the drive for the terminals of all active command sources is the following:

- **AND** for the terminals allocated to the **ENABLE** functions (**MDI2&S** inputs on physical terminals, **MDI2** via serial command or fieldbus), **ENABLE-SW**, **External Alarms n.1, n.2, n.3**.
- **OR** for all other terminals.



**NOTE**

If the keypad is enabled as a command source, the **START, STOP, RESET, LOC/REM, FWD/REV** functions are enabled (to disable **LOC/REM** and **FWD/REV** see parameter **P269**). The keypad is ignored for the processing of logic functions (AND/OR) of the other command sources that are enabled at that moment.



**NOTE**

As the **ENABLE-A** and **ENABLE-B** commands of the physical terminal board are a hardware safety device (they enable the drive) they are always active, even when none of parameters **C140, C141** or **C142** selects the terminal board (=1).

If the **STO** function is to be adopted, the control mode and the control circuit of these signals must be accomplished as per the Safe Torque Off Function - Application Manual. That manual also includes a detailed validation procedure of the control configuration of the **STO** function to be executed upon first start-up and also periodically at yearly intervals.



**NOTE**

The commands for the **External Alarm n.1, n.2, n.3** functions are always considered for the drive terminal board only.



**NOTE**

The **LOCAL mode**, that can be enabled with the **LOC/REM** key from the keypad or with the **LOCAL** command function from the terminal board (see **C180**), forces the keypad as the only command source, thus ignoring the values set in parameters **C140, C141, C142**.

The following functions are therefore enabled for the hardware terminal board: **External Alarm n.,1 n.2, n.3, Motor Sel. n.2, Motor Sel. n.3, SLAVE, Source Selection, LOCAL** and the **ENABLE-A** and **ENABLE-B** and **RESET** functions are always enabled for terminals **MDI2, S** and **MDI3**.

The **ENABLE-SW** and **DISABLE** functions are enabled in **LOCAL** mode if at least one of parameters **C140, C141, C142** is set to 1 (terminal board).

**Table 88: Remote command inputs from serial link**

| MODBUS Address | Input Code | User Level | Description  | Range   |
|----------------|------------|------------|--|---|
| 1406           | I019       | BASIC      | Remote, virtual terminal board from serial link    | Bit input: 0÷1 for 8 bits corresponding to MDI1÷ MDI8   |
| 1407           | I020       | BASIC      | Auxiliary, virtual terminal board from serial link | Bit input: 0÷1 for 8 bits corresponding to XMDI1÷ XMDI8 |

**Example:**

If **C140 = 3** (Fieldbus) and **C141 = 2** (Serial link), the **ENABLE** command is sent by closing terminals **ENABLE-A** and **ENABLE-B** on the terminal board and (AND) by forcing bit **MDI2** from the serial link on input **I019** (MODBUS address: 1406) and bit **MDI2** from Fieldbus (see the FIELDBUS CONFIGURATION MENU).

The **START** command may also be sent (OR) by forcing bit **MDI1** from serial link on input **I019** or by forcing bit **MDI1** from Fieldbus for the relevant variable.

### 36.1.2. SPEED/TORQUE REFERENCE SOURCES

The “**main reference**” is the value at constant speed to be attained by the controlled variable (speed or torque) (M000, M007) “required” from the drive.

This reference is acquired by the drive only if the **START** command and the **ENABLE-A** and **ENABLE-B** commands are active; otherwise, it is ignored.

When the main reference is acquired by the drive (**START**, **ENABLE-A** and **ENABLE-B** are active), it becomes the input signal controlled by the “time ramp” functions that generate the speed/torque reference setpoint for the connected motor.

The speed or torque references may come from the following command sources:

0. **Source disabled;**
1. **REF** (single-ended analog input from terminal board);
2. **AIN1** (differential analog input from terminal board);
3. **AIN2** (differential analog input from terminal board);
4. **FIN** (frequency input from terminal board; see also the ENCODER/FREQUENCY INPUTS MENU);
5. **Serial link** (with MODBUS protocol);
6. **Fieldbus** (fieldbus in optional board);
7. **Keypad** (remotable display/keypad);
8. **Encoder** (in terminal board MDI6–ECHA, MDI7–ECHB or optional board);
9. **Up Down from MDI** (Up/down from digital inputs, see **C161** and **C162**)
10. **XAIN4** (auxiliary, differential voltage analog input from ES847 terminal board)
11. **XAIN5** (auxiliary, differential current analog input from ES847 terminal board)

With factory-setting, only one source is enabled (**C143=1**, **C144=2**, **C145=0** and **C146=0**). Because the digital input for source selection is programmed (**C179=6: MDI6**, see Digital Inputs Menu), if this input is inactive, only the REF item is selected (please refer to the INPUTS FOR REFERENCES MENU).

If multiple reference sources are enabled, by programming also **C144**, **C145**, or **C146**, the actual calculated reference is the algebraic sum of all the references that are enabled (see How to Manage the Reference Sources).

#### REF, AIN1 and AIN2

The sources called REF, AIN1 and AIN2 come from the analog inputs in the terminal board and generate a reference resulting from the setting of the relevant parameters (from **P050** to **P064**). See the INPUTS FOR REFERENCES MENU for the scaling, offset compensation and filtering of the reference obtained. The inputs may be used as voltage or current inputs depending on the setting and the position of the relevant dip-switches (see the Sinus Penta’s Installation Guide).

#### FIN

The **FIN** source is a frequency input on terminal **MDI6 (FINA)** or **MD18 (FINB)** and it generates a reference determined by the setting of the relevant parameters (from **P071** to **P072**), allowing proper scaling (see the INPUTS FOR REFERENCES MENU and the ENCODER/FREQUENCY INPUTS MENU).

#### SERIAL LINK

The **Serial Link** source is an input located on the MODBUS link: the reference value must be written by the user to the addresses below:

Table 89: Reference inputs from serial link

| MODBUS Address | Input Code | User Level | Reference | Description                             | Range                     | Unit of measure |
|----------------|------------|------------|-----------|---|---------------------------|-----------------|
| 1412           | I025       | BASIC      | Speed     | Speed reference/limit (integer portion) | Min. speed ÷ Max. speed   | RPM             |
| 1413           | I026       | BASIC      | Speed     | Speed reference/limit (decimal portion) | -99 ÷ 99                  | RPM/100         |
| 1416           | I029       | BASIC      | Torque    | Torque reference/limit                  | Min. torque ÷ Max. torque | Tenths %        |



NOTE

I025 is the speed reference if at least one among parameters C143..146 is set to 5:Serial Link and the type of reference of the active motor (parameters C011 / C054 / C097) is set to 0:Speed; I025 is the speed limit if C147=5:Serial Link and the type of reference of the active motor is set to 2:Torque with Speed Limit. The range of this reference depends on the active Minimum Speed value and Maximum Speed value as set in parameters C028 and C029 (for motor 1, and relevant parameters for motor 2 and motor 3).

If C029 ≤ C028, then **Min. speed = C029, Max. speed = C028.**

If C029 ≥ C028, then **Min. speed = C028, Max. speed = C029.**



NOTE

I026 is the decimal portion of the speed reference in RPM and has effect in FOC motor control mode only.



NOTE

I029 is used as a torque reference if at least one among parameters C143..146 is set to 5:Serial Link and the type of reference of the active motor (parameters C011 / C054 / C097) is set to 1:Torque or 2:Torque with Speed Limit. I029 is used as a torque limit if C147=5:Serial Link.

I029 is expressed as a percentage of the max. absolute torque set with the parameters C047 and C048 (motor 1, and relevant parameters for motor 2 and motor 3). The max. absolute torque is the max. value between absolute values of parameters C047 and C048.

**Max. absolute torque = Max( | C047 | , | C048 | )**

The unit of measure is tenths of %:

**Torque reference % = (I029\*0.1) %**

Reference range:

If C047 ≤ C048, then **Min. torque = C047, Max. torque = C048.**

If C047 ≥ C048, then **Min. torque = C048, Max. torque = C029.**

Example: 1200 = 120.0%

## FIELD BUS

For a description of the **Fieldbus** source, see the FIELD BUS CONFIGURATION MENU.

## KEYPAD



NOTE

The keypad is a special reference source. The keypad reference may be changed with the ▲ and ▼ keys only if this reference is on a Keypad page displaying a reference in line 4.

If the keypad is enabled, a **variation** to the active reference may be added through an algebraic sum (calculated by processing the other reference sources that are activated at that moment).

The reference variation method can be selected with parameters P067, P068, P069, and C163.

This function is the same as the **UP** and **DOWN** functions from the terminal board (see the DIGITAL INPUTS MENU: C161 and C162 and P068÷P069 in the INPUTS FOR REFERENCES MENU).



NOTE

The **LOCAL mode**, that can be enabled with the **LOC/REM** key on the keypad or with the **LOCAL** command function from terminal board (see C180), forces the keypad to become the only command and reference source, thus ignoring the values set in parameters C143, C144, C145, C146.

**ENCODER**

The **Encoder** source is an encoder input: it can come from the terminal board (terminals **MDI6**, **MDI7**) in Encoder A, or from the optional Encoder B board (see the ENCODER/FREQUENCY INPUTS MENU). It generates a reference resulting from the correct setting of the relevant parameters (**P073**, **P074**), allowing the relevant scaling (see the INPUTS FOR REFERENCES MENU).

**UP/DOWN from digital inputs**

To enable the **UP/DOWN from digital inputs** also set the relevant Up and Down inputs (see the DIGITAL INPUTS MENU).

**XAIN4 and XAIN5**

**XAIN4 and XAIN5** come from the analog inputs in the terminal board of ES847 and generate a reference determined by the settings of the relevant parameters (**P390** to **P399**), allowing proper scaling, offset compensation and filtering (see the INPUTS FOR REFERENCES FROM OPTIONAL BOARD ).

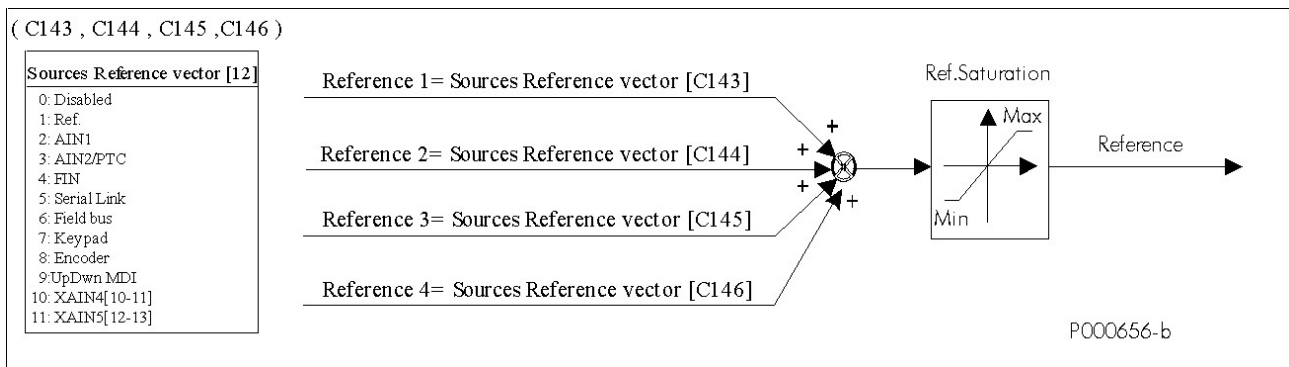

**Figure 46: Selecting the source references**

### 36.1.3. ALTERNATIVE COMMAND AND REFERENCE SOURCES

A digital input can be set as a selector between 2 alternative command and reference sources.

Example:

- C179** MDI To select sources = **MDI6**
- C140** To select command source number 1 = **Keypad**
- C141** To select command source number 2 = **Fieldbus**
- C143** To select reference source number 1 = **AIN1**
- C144** To select reference source number 2 = **Fieldbus**

If **MD16** (in the drive terminal board) set as a selector is open, the drive will consider number 1 as reference and command sources (that is **C140 = Keypad** and **C143 = AIN1**); if it is closed, number 2 will be considered (**C141 = Fieldbus** and **C144 = Fieldbus**). See also How to Manage the Reference Sources.

If references sources 3 and 4 (**C145** and **C146**) are not set to Disable, the reference sent for these sources shall be a sum of the source selected by MD16 vector.

Please refer to **C179** in the DIGITAL INPUTS MENU.

### 36.1.4. TORQUE LIMIT SOURCE

The source of the Torque Limit can be selected with parameter **C147**.

The Torque limit function is a limit of the absolute value of the torque required from the drive.  
 (– Torque limit) <= torque <= (+ Torque limit)

The torque limit references may be selected from the following:

#### 0. Source disabled

1. **REF** (single-ended analog input from terminal board);
2. **AIN1** (differential analog input from terminal board);
3. **AIN2** (differential analog input from terminal board; see also the ENCODER/FREQUENCY INPUTS MENU);
4. **FIN** (frequency input from terminal board);
5. **Serial link** (with MODBUS protocol);
6. **Fieldbus** (fieldbus on optional board);
7. **Keypad** (remotable display/keypad);
8. **Encoder** (in terminal board MDI6–ECHA , MDI7–ECHB or optional board);
9. **Up Down from MDI** (Up/down from digital inputs, see **C161** and **C162**)
10. **XAIN4** (auxiliary, differential voltage analog input from ES847 terminal board)
11. **XAIN5** (auxiliary, differential current analog input from ES847 terminal board)



#### NOTE

If the reference source is disabled, the torque limit results from the max. absolute torque determined by the drive size and the motor size.

The max. absolute torque is the max. value ranging between the absolute values of **C047** and **C048** (motor 1, and relevant parameters for motor 2 and motor 3).

**Max. absolute torque** = Max( | **C047** | , | **C048** | )

Factory setting is **C147**=0: the reference source is disabled and the torque limit is given by the max. absolute torque.

### 36.1.5. REMOTE/LOCAL MODE

According to factory-setting, switching over from the **Remote** mode to the **Local** mode can only be made when the drive is disabled. The reference and command sources for the **Remote** mode depend on the settings of parameters **C140** to **C147** in the CONTROL METHOD MENU and on the settings of parameters **C285** to **C287** in the PID CONFIGURATION MENU. When switching over from the Remote mode to the Local mode, the command and reference can be sent via keypad only. This is true for the switch over from the **Local** to the **Remote** mode as well.

Parameter **C148** allows customizing the Loc/Rem function so that it can be performed even when the drive is running. Parameter **C148** also allows setting whether the same running condition and the same reference must be maintained when switching over from the Remote to the Local mode.



#### NOTE

For more details on the Loc/Rem function, see LOC/REM Key (Keypad Pages) and DIGITAL INPUTS MENU.

## 36.2. How to Manage the Reference Sources

This section covers how to manage the reference sources.

Two examples are given along with the table including the configuration of the parameters to be used.

### Example 1: The Speed Reference is the algebraic sum of two references

Analog inputs REF and AIN1 (that are supposed to be 0-10V voltage inputs) are to be used as speed references. The main reference will be the sum of the two references being used. The end result may vary based on the parameters concerned.

|              |  |            |
|--------------|--|------------|
| <b>P050</b>  | Type of Reference for REF Input                | 3: 0-10V   |
| <b>P051</b>  | Value of REF Input producing Min. Reference    | 0.0V       |
| <b>P051a</b> | Percentage of Ref_Min producing Min. Reference | 100.0%     |
| <b>P052</b>  | Value of REF Input producing Max. Reference    | 10.0V      |
| <b>P052a</b> | Percentage of Ref_Max producing Max. Reference | 100.0%     |
| <b>P055</b>  | Type of Signal over AIN1 input                 | 3: 0-10V   |
| <b>P056</b>  | Value of AIN1 Input producing Min. Reference   | 0.0V       |
| <b>P056a</b> | Percentage of Ref_Min producing Min. Reference | 100.0%     |
| <b>P057</b>  | Value of AIN1 input producing Max. Reference   | 10.0V      |
| <b>P057a</b> | Percentage of Ref_Max producing Max. Reference | 100.0%     |
| <b>C028</b>  | Min. Motor Speed                               | 0rpm       |
| <b>C029</b>  | Max. Motor Speed                               | 1500rpm    |
| <b>C143</b>  | Selection of Reference 1                       | 1: REF     |
| <b>C144</b>  | Selection of Reference 2                       | 2: AIN1    |
| <b>C179</b>  | MDI for Source Selection                       | 0: Disable |

**C179=0: Disable** ensures that the main reference is the sum of the references being used. If a digital input for Source selection were used, either one reference would be selected as the main reference based on the input status.

Both REF and AIN1 references are programmed in order to meet the following requirements:

- at 0V, they are expected to generate 100% of the minimum motor speed reference (**C028**), i.e. 0rpm
- at 10V, they are expected to generate 100% of the maximum motor speed reference (**C029**), i.e. 1500rpm

The main reference will be their sum and will start from 0rpm (when both references are at 0V) and its maximum value would be 3000rpm (when both references are at 10V), but it will be limited to 1500, as set by **C029**, as soon as the sum of the two references exceeds 1500rpm.

Suppose that the parameters below are to be programmed (only the parameters changing with respect to the example above are given):

|             |                  |       |
|-------------|------------------|-------|
| <b>C028</b> | Min. Motor Speed | 50rpm |
|-------------|------------------|-------|

As the minimum motor speed is set to 50rpm, each of the two references, at 0V, will generate a reference equating 100% of 50rpm, i.e. 50rpm. The minimum value of the main reference, that is the sum of the two references, will then equating 100rpm if the two references are at 0V.

If the main reference shall start from 50rpm, that is it can generate the minimum motor speed, the following parameters shall be set accordingly:

|              |  |       |
|--------------|--|-------|
| <b>P051a</b> | Percentage of Ref_Min producing Min. Reference | 50.0% |
| <b>P056a</b> | Percentage of Ref_Min producing Min. Reference | 50.0% |

In that way, either references at 0V will generate 50% of 50rpm, i.e. 25rpm. Their sum will be worth 50rpm at a minimum, as required.

If the whole resolution of the references is to be exploited, so that:

- at 0V, for both references, the minimum speed is 50rpm
- at 10V, for both references, the maximum speed is 1500rpm

then the following shall be programmed:

|              |  |       |
|--------------|--|-------|
| <b>P052a</b> | Percentage of Ref_Max producing Max. Reference | 50.0% |
| <b>P057a</b> | Percentage of Ref_Max producing Max. Reference | 50.0% |

In that way, each reference will range from 25 to 750rpm and their sum will range from 50 and 1500rpm, as required.

**Example 2: Speed references alternatively selected**

The two REF analog inputs are to be used as alternative speed references. The following parameters shall be programmed accordingly:

|              |  |          |
|--------------|--|----------|
| <b>P050</b>  | Type of Reference for REF Input                | 3: 0-10V |
| <b>P051</b>  | Value of REF Input producing Min. Reference    | 0.0V     |
| <b>P051a</b> | Percentage of Ref_Min producing Min. Reference | 100.0%   |
| <b>P052</b>  | Value of REF Input producing Max. Reference    | 10.0V    |
| <b>P052a</b> | Percentage of Ref_Max producing Max. Reference | 100.0%   |
| <b>P055</b>  | Type of Signal over AIN1 input                 | 3: 0-10V |
| <b>P056</b>  | Value of AIN1 Input producing Min. Reference   | 0.0V     |
| <b>P056a</b> | Percentage of Ref_Min producing Min. Reference | 100.0%   |
| <b>P057</b>  | Value of AIN1 input producing Max. Reference   | 10.0V    |
| <b>P057a</b> | Percentage of Ref_Max producing Max. Reference | 100.0%   |
| <b>C143</b>  | Selection of Reference 1                       | 1: REF   |
| <b>C144</b>  | Selection of Reference 2                       | 2: AIN1  |
| <b>C179</b>  | MDI for Source Selection                       | 6: MDI6  |

As MDI6 input is selected as reference source selection (**C179**), the references selected via **C143** and **C144** are selected as the main reference depending on the input status. When the input is inactive, REF will be the main reference; when the input is active, AIN1 will be the actual reference.

### 36.3. List of Parameters C140 to C148

Table 90: List of parameters C140 to C148

| Parameter   | FUNCTION                                 | User Level  | MODBUS Address | Default Values        |
|-------------|--|-------------|----------------|-----------------------|
| <b>C140</b> | Command digital input 1                  | ADVANCED    | 1140           | 1:Terminal Board      |
| <b>C141</b> | Command digital input 2                  | ADVANCED    | 1141           | 1:Terminal Board      |
| <b>C142</b> | Command digital input 3                  | ENGINEERING | 1142           | 0                     |
| <b>C143</b> | Input reference 1                        | ADVANCED    | 1143           | 1: REF                |
| <b>C144</b> | Input reference 2                        | ADVANCED    | 1144           | 2: AIN1               |
| <b>C145</b> | Input reference 3                        | ENGINEERING | 1145           | 0                     |
| <b>C146</b> | Input reference 4                        | ENGINEERING | 1146           | 0                     |
| <b>C147</b> | Torque Limit input                       | ENGINEERING | 1147           | 0                     |
| <b>C148</b> | Switch over from Remote to Local command | ENGINEERING | 1148           | 0: StandBy or Fluxing |



**NOTE** The programming range of parameters **C140**, **C141**, **C142** depends on the setting of parameter **C150** and vice versa (see the detailed description of the parameters above).

#### C140 (C141, C142) Command Source Selection 1 (2, 3)

|                          |                 |  |  |
|--------------------------|-----------------|--|--|
| <b>C140 (C141, C142)</b> | <b>Range</b>    | 0 ÷ 5  | 0: Disabled,<br>1: Terminal Board,<br>2: Serial Link,<br>3: Fieldbus,<br>4: Terminal Board B,<br>5: Keypad |
|                          | <b>Default</b>  | <b>C140 ÷ C141</b> = 1<br><b>C142</b> = 0            | <b>C140 ÷ C141</b> = 1: Terminal Board<br><b>C142</b> = 0: Disabled  |
|                          | <b>Level</b>    | <b>C140 ÷ C141</b> ADVANCED; <b>C142</b> ENGINEERING |  |
|                          | <b>Address</b>  | 1140 (1141,1142)                                     |  |
|                          | <b>Function</b> | Selection of the drive command source.               |  |



**NOTE**

If the command source is set as Keypad, different command sources can be set up only if the STOP or STOP B digital inputs are programmed (see **C150** and **C150a**) to enable pushbutton operation or to make sure that the Source Selection function is activated (see **C179**).



**NOTE**

If the first command source is already set and it is not a Keypad source, you can set the Keypad as a second or third source, only if the STOP or STOP B inputs are programmed (**C150** ≠ 0 or **C150a** ≠ 0) to enable pushbutton operation or to make sure that the Source Selection function is activated (see **C179**).



**NOTE**

If the digital input for source selection (parameter **C179** in the Digital Inputs Menu) is set to a value other than 0: Disabled, parameter **C142** (Command source selection 3) has no effect, as if it was set to 0: Disabled.

**C143 (C144, C145, C146) Reference 1 (2, 3, 4) Selection**

|                                |                 |   |   |
|--------------------------------|-----------------|---|---|
| <b>C143 (C144, C145, C146)</b> | <b>Range</b>    | 0 ÷ 9<br>0 ÷ 11 if ES847 is in  | 0: Disabled<br>1: REF<br>2: AIN1<br>3: AIN2<br>4: Frequency input<br>5: Serial Link<br>6: Fieldbus<br>7: Keypad<br>8: Encoder<br>9: UpDown from MDI<br>10: XAIN4<br>11: XAIN5 |
|                                | <b>Default</b>  | <b>C143 = 1, C144 = 2</b><br><b>C145 ÷ C146 = 0</b>   | <b>C143 = 1: REF, C144 = 2: AIN1</b><br><b>C145 ÷ C146 = 0 : Disabled</b>   |
|                                | <b>Level</b>    | <b>C143 ÷ C144 ADVANCED; C145 ÷ C146 ENGINEERING</b>  |   |
|                                | <b>Address</b>  | 1143 (1144, 1145, 1146)   |   |
|                                | <b>Function</b> | This parameter selects the sources for the speed (or torque) reference. The reference resulting from the sum of the selected sources represents the drive speed or torque reference. If the PID action has been set as reference <b>C294 = Reference</b> , the drive speed or torque references shall only be given by the PID output and not by the sources set in <b>C143 ÷ C146</b> . Reference sources 10 and 11 can be selected only after setting XAIN in parameter R023. |   |

**C147 Torque Limit Input**

|             |                 |  |   |
|-------------|-----------------|--|---|
| <b>C147</b> | <b>Range</b>    | 0 ÷ 9  | 0: Disabled<br>1: REF<br>2: AIN1<br>3: AIN2<br>4: Frequency input<br>5: Serial Link<br>6: Fieldbus<br>7: Keypad<br>8: Encoder<br>9: UpDown from MDI<br>10: XAIN4<br>11: XAIN5 |
|             | <b>Default</b>  | 0  | 0: Disabled   |
|             | <b>Level</b>    | ENGINEERING  |   |
|             | <b>Address</b>  | 1147   |   |
|             | <b>Control</b>  | VTC and FOC  |   |
|             | <b>Function</b> | If a speed control with FOC or VTC control algorithms is used, an external torque limit can be used. Parameter <b>C147</b> selects the Torque Limit source. The torque ramp times set in <b>P026–P027</b> will be applied to the torque limit reference source that has been selected. The external torque limit may be disabled by closing the digital input set with <b>C187</b> . Limiting sources 10 and 11 can be selected only after setting XAIN in parameter <b>R023</b> . |   |



**NOTE**

If the reference source is disabled, the torque limit results from the max. absolute torque determined by the drive size and the motor size.  
 The max. absolute torque is the max. value ranging between the absolute values of **C047** and **C048** (motor 1, and relevant parameters for motor 2 and motor 3).  
**Max. absolute torque** = Max( | **C047** | , | **C048** | )

Factory-setting : the reference source is disabled (**C147**=0), so the torque limit depends on the max. absolute torque (see also the INPUTS FOR REFERENCES MENU).

**C148 Switch over from Remote to Local Command**

|             |                 |   |   |
|-------------|-----------------|---|---|
| <b>C148</b> | <b>Range</b>    | 0 ÷ 3   | 0: StandBy + Fluxing<br>1: Drive Running / No Bumpless<br>2: Drive Running / Commands Bumpless<br>3: Drive Running / All Bumpless |
|             | <b>Default</b>  | 0   | 0: StandBy or Fluxing   |
|             | <b>Level</b>    | ENGINEERING   |   |
|             | <b>Address</b>  | 1148  |   |
|             | <b>Function</b> | <p>The drive factory-setting (0: StandBy or Fluxing) allows switching over from Remote to Local mode (and vice versa) only when the drive is not running.<br/>                     Different settings allowed by parameter <b>C148</b> are detailed below; switching from Remote to Local mode (and vice versa) can be performed even when the drive is running:</p> <ul style="list-style-type: none"> <li>• <b>No Bumpless</b> → When switching from Remote to Local mode, a “zero” speed or torque reference is sent to the drive; the <b>START</b> button must be pressed to start the drive.</li> <li>• <b>Commands Bumpless</b> → When switching from Remote to Local mode, a “zero” speed or torque reference is sent to the drive, but the running conditions are the same as in Remote mode. For example, if the motor is running in Remote mode, the drive still runs even in Local mode and the reference can be changed with the <b>INC/DEC</b> key, starting from “zero”.</li> <li>• <b>All Bumpless</b> → When switching from Remote to Local mode, the drive maintains the same speed/torque reference and the same running condition as in Remote mode. For example, if the motor is running at 1000 rpm in Remote mode, the drive still runs even in Local mode with a reference of 1000 rpm that can be changed with the <b>INC/DEC</b> key, starting from “zero”.</li> </ul> |   |



**NOTE**

Parameter **C148** affects parameters **C140** to **C147** and **C285** to **C287** (see PID CONFIGURATION MENU) when the PID controller is enabled.

### 37. DIGITAL INPUTS MENU

#### 37.1. Overview



**NOTE** Please refer to the Sinus Penta's Installation Guide for the hardware description of the digital inputs.

The parameters contained in this menu assign particular digital control functions to each digital input in the terminal board. Each parameter has a particular function, which is assigned to a given terminal on the terminal board.

**Figure 47: Inputs that can be selected to implement control functions**

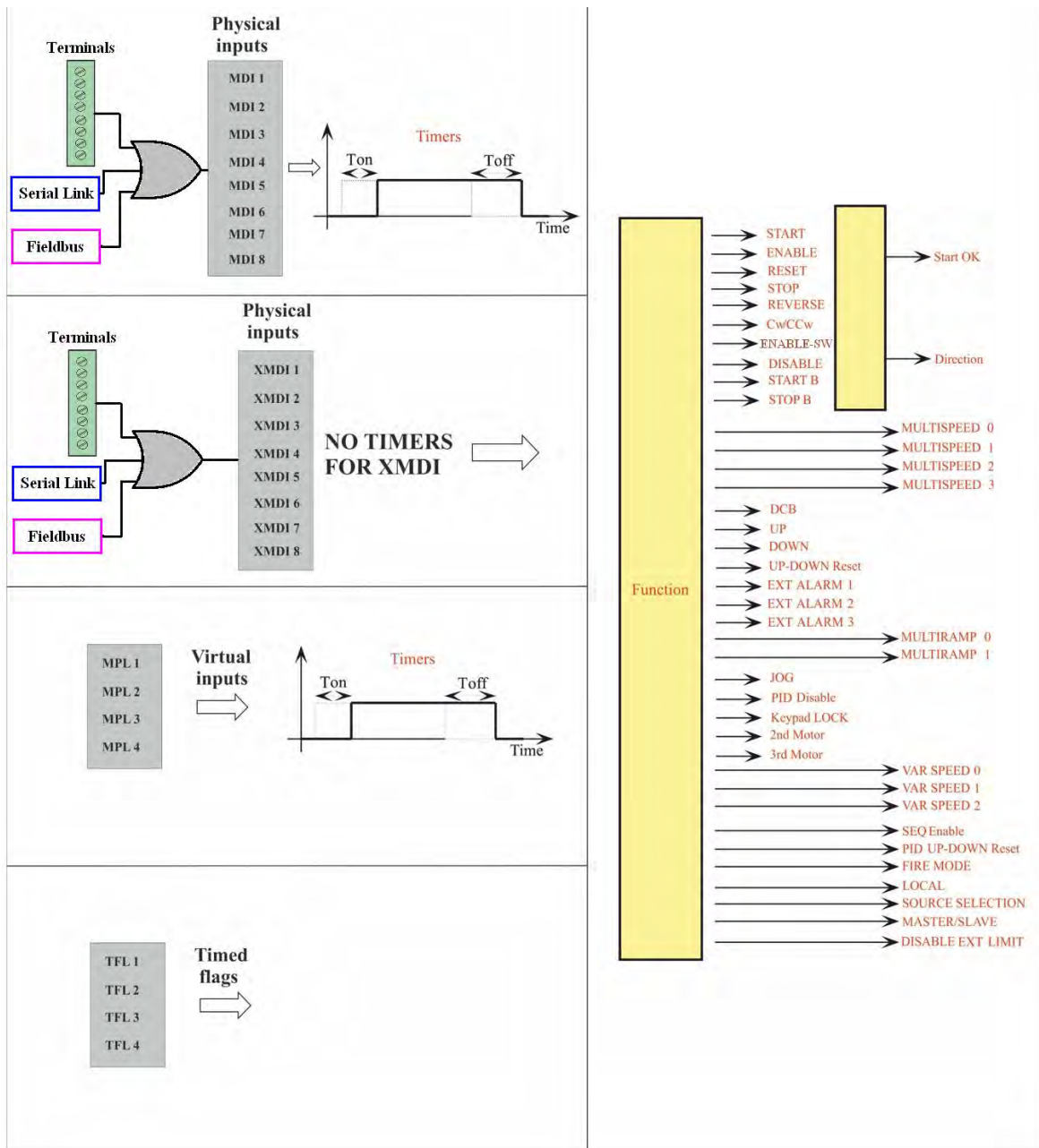

S000248

The full processing of the digital inputs also includes the selection of other remote/virtual terminal boards (see the CONTROL METHOD MENU) and the possibility of delaying input digital signal enable/disable by means of software timers (see the TIMERS MENU).

The digital input status is displayed in measures **M031**, **M032**, **M033**, **M034**, **M035**.

Measure **M033** shows the **current** status of the 8 inputs in the local hardware terminals in the drive board. The input called **MDI2&S** ("S" on the display keypad) is active only if both physical inputs **ENABLE-A** and **ENABLE-B** are active.

The symbol  displays the logic levels for terminals **M033** for inactive inputs; the active inputs are marked with .

Measures **M034** and **M035** show the status of the terminal boards that can be activated via serial link and fieldbus respectively.

Measure **M032** shows the **current** status of the virtual terminal board obtained by processing all active terminal boards. It includes 10 signals, with two additional signals with respect to the local hardware terminal board:

- Inputs **MDI1** to **MDI8** are obtained with the **logic OR** of the input signals for all active terminals;
- The **ENABLE** function is obtained with the logic **AND** of the input signals for terminal **MDI2&S** (physical terminal board)/**MDI2** (serial link and fieldbus) in all active terminal boards;
- The **ENABLE-SW** function is obtained with the logic **AND** of the terminals selected for this function in all active terminal boards.

Measure **M031** is similar to **M032**, but it displays the status of the terminal board obtained after delaying the input signals of **M032** using special timers.

The drive uses this terminal board to acquire digital commands.

Some functions cannot be programmed, but they are assigned to special terminals:

**Table 91: Unprogrammable functions**

| Function | Terminal                                   |
|----------|--|
| ENABLE   | MDI2                                       |
| RESET    | MDI3 (can be disabled if <b>C154</b> =Yes) |

Some terminals in the local hardware terminal board can also be used for different functions:

**Table 92: Terminals used for other inputs**

| Terminal | Description   |
|----------|---|
| MDI6     | ECHA: channel A of <b>encoder A</b> in the terminal board |
| MDI7     | ECHB: channel B of <b>encoder A</b> in the terminal board |
| MDI8     | FIN: frequency input                                      |

### 37.1.1. START

The **START** function may be assigned to a digital input (MDI1..8); to an auxiliary digital input (XMDI1..8); to a virtual auxiliary digital output (MPL1..4) or to a timed flag (TFL1..4). The input programming is set via parameter **C149**.

To enable the Start input, set the control modes via terminal board (factory setting). The **START** command can also be sent from the display/keypad. The programmed input Enable/Disable can be delayed via special timers.

The **START** input function is assigned to MDI1 terminal by default, but it can be assigned to other terminals as well. The same terminal programmed as **START** may be allocated to different functions as well.

The motor stop mode (**C185**) can be programmed. When removing the **START** command, the following motor stop modes can activate:

the motor stops following a deceleration ramp or starts idling; the motor is fluxed (VTC, FOC) only when the **START** command is shut down and the **ENABLE** is not active (**C184**).

When **START** is **active** (and when the **ENABLE** function is active as well), the **RUN** command is enabled: the speed (or torque) *setpoint* increases proportionally to the preset ramp until it reaches the active *reference*. (IFD control: in order to enable the RUN command, the main speed reference must be other than zero).

When **START** is **inactive** (also when the **ENABLE** is active), the **RUN** command is disabled: the reference is set to zero and the speed (or torque) setpoint decreases down to zero depending on the preset deceleration ramp.

The way the **START** enables or disables the **RUN** command also depends on the setup of other functions, in particular the **STOP**, **REVERSE** and **JOG** functions (see parameters **C150**, **C151**, **C169**).

If the **REVERSE** (**C151**≠0) function is enabled, it can enable/disable the **RUN** command. However, if the **START** and **REVERSE** commands are both active, the **RUN** command is disabled.



**NOTE** *In this case, **START** is interpreted as FORWARD and **REVERSE** as REVERSE. When both Start and Reverse are active, the system cannot interpret the query to be FORWARD or REVERSE.*

If the **JOG** function is enabled (**C169**≠0), it can enable/disable the **RUN** command, but only if the **RUN** command has not been previously enabled by other functions.

If the **STOP** function is enabled (**C150**≠0), the **RUN** command may be enabled/disabled only by pressing the relevant "key": see the description of the **STOP** function (**C150**).



**NOTE** If only the keypad is enabled as the command source, press the **START** key located on the keypad to enable the drive **RUN** and press the **STOP** key to disable the drive **RUN**.



**NOTE** If **C185** = Free Wheel when removing the **START** command, the drive will not carry out the deceleration ramp and will be put on stand-by.

### 37.1.2. ENABLE (TERMINALS 15:MDI2 AND S)

The **ENABLE** function is assigned to terminals **ENABLE-A (MDI2)** and **ENABLE-B (S)** (the series-connection of those inputs activates the **MDI2&S** input as displayed in **M033**) and **enables the drive operation**. It cannot be set to other terminals, whereas the same terminal may be assigned to different functions.

The **ENABLE** function is detailed in the figure below:

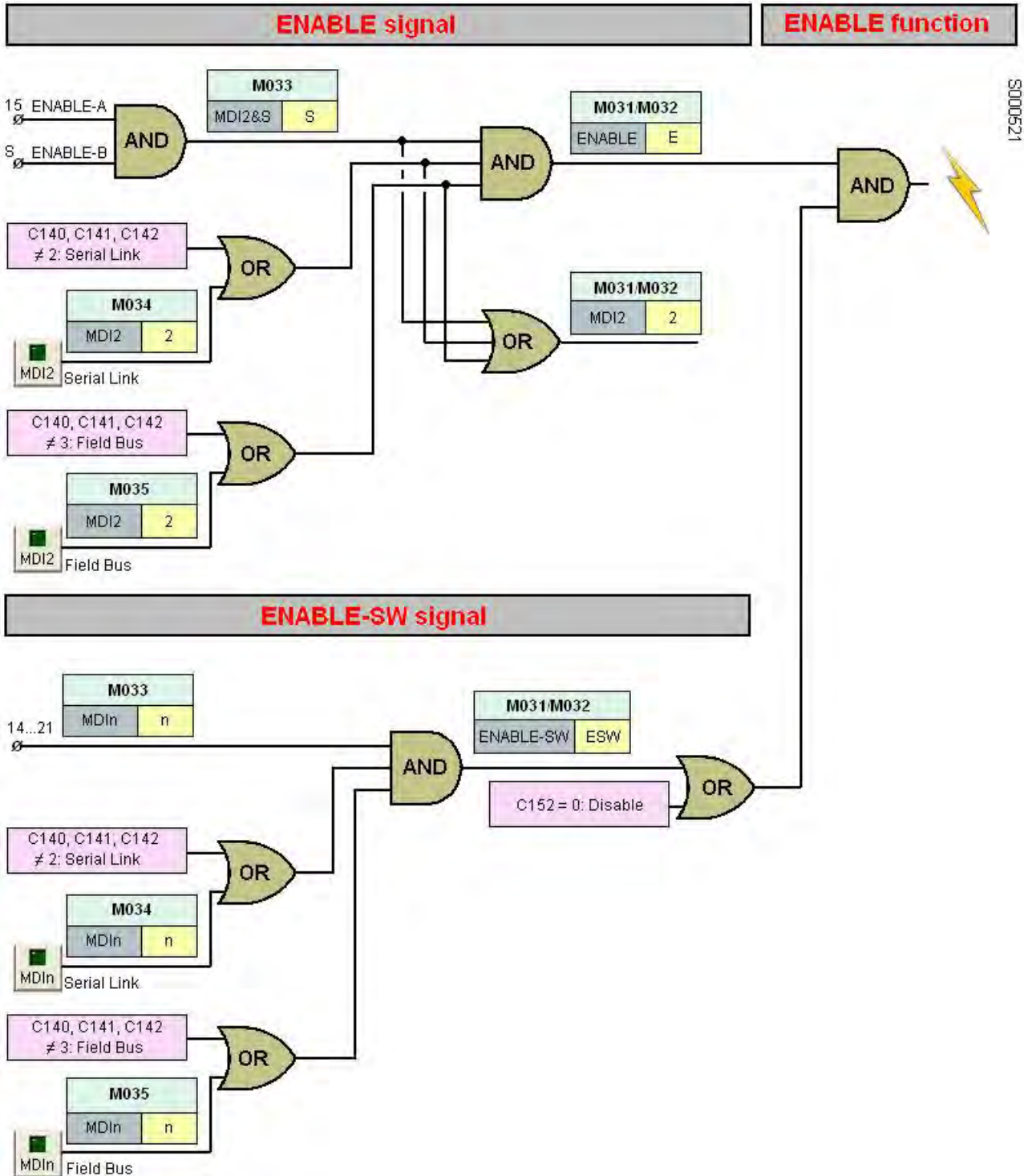

Figure 48: The ENABLE Function

**NOTE**

In order to enable the drive operation:

- **ENABLE-A** and **ENABLE-B** inputs must be active. In that way, **MDI2&S** displayed in measure **M033** will be active;
- **MDI2** input must be active on all programmed terminal boards (serial link and fieldbus – CONTROL METHOD MENU).

If the STO function is to be adopted, the control mode and the control circuit of the **ENABLE-A** and **ENABLE-B** signals must be accomplished as per the Safe Torque Off Function - Application Manual.

That manual also includes a detailed validation procedure of the control configuration of the STO function to be executed upon first start-up and also periodically at yearly intervals.

If the **ENABLE** input is disabled, the drive output voltage is always set to zero, so the connected motor starts **idling** (the motor idles and stops due to friction or the mechanical load).

In case of pulled loads (e.g. lifting applications), when the motor is idling, the mechanical load could cause the motor to run at uncontrolled speed!

If the **ENABLE** input is disabled when the drive is controlling the motor, it is closed with a delay time depending on the drive size. This **ENABLE** delay starts from the instant when the input is disabled irrespective of the enable delay (if any) set through a software timer in **MDI2**.

The operating mode and the logic used by the **ENABLE** input to enable/disable the drive also depends on the programming of the **DISABLE** and **ENABLE-SW** functions described below.

If the **IFD** control is used, the drive enabling also depends on the **START** input and the current value of the active reference: if the **START** command is active but the reference is lower than the preset threshold, the drive operation is disabled. To enable this operating mode with other types of control, parameters **P065** and **P066** must be set accordingly.

The drive may also be disabled by the **PID** regulator (see parameter **P255**).

**DANGER!!!**

The deactivation of the **ENABLE-SW** signal, the activation of the **DISABLE** signal, the deactivation of **MDI2** inputs from serial link or fieldbus DO NOT GUARANTEE that the Safe Torque Off – STO function is removed from the motor connected to the drive.

Safety stop conditions are guaranteed only when at least one of the two **ENABLE-A** and **ENABLE-B** inputs are opened.

For more details, consult the Safe Torque Off Function - Application Manual.

**CAUTION**

If the **MDI2** inputs are disabled for one of the active terminal boards, the drive is instantly disabled and the motor starts idling! If so, the mechanical load could cause uncontrolled acceleration/slowing down of the connected motor!

**CAUTION**

If the physical **ENABLE-A** or **ENABLE-B** inputs are opened, the drive is disabled and the motor starts idling! If this is the case, the mechanical load can cause uncontrolled acceleration/slowing down of the connected motor.

**CAUTION**

If a protection/alarm trips, the drive disables and the motor starts idling!

**NOTE**

If software timers are enabled for digital inputs, the timer for the **MDI2** input delays the signal enabling. The **ENABLE** signal is always instantly disabled (*for the **ENABLE** function, Toff in **MDI2** is ignored*).

**NOTE**

The activation of the **ENABLE** command enables the alarms controlling the configuration consistency of certain parameters.

**NOTE**

When the **ENABLE** function is active, C parameters cannot be changed (factory-setting). If **P003** Condition required for changing C parameters = Standby+Fluxing, the parameters may be changed even if the drive is enabled but the motor is not running.

**NOTE**

When the **ENABLE** function is active for VTC and FOC controls, the motor is fluxed by the drive. Motor fluxing is allowed only if the **START** contact is shut down and **C184** = Yes.

**NOTE**

If set accordingly, safety parameter **C181** prevents the drive from starting if the **ENABLE** function is already active when the drive is powered on.

### 37.1.3. RESET (TERMINAL 16:MDI3)

The **RESET** function is assigned to input terminal **MDI3**. It resets the alarms to unlock the drive operation. It cannot be set to other terminals, whereas the same terminal may be assigned to different functions. To disable the reset function from terminal MDI3, set **C154** = Yes.

If a protection trips, the drive locks, the **motor starts idling** (the motor idles and stops due to friction or the mechanical load) and an alarm message is displayed (see also the AUTORESET MENU and the ALARMS AND WARNINGS section).

#### Reset procedure

To unlock the drive, activate the **RESET** input for an instant, or press the **RESET** key from the keypad. When the drive unlocks and the cause responsible for the alarm has disappeared, "Inverter ok" comes up on the screen, otherwise, the alarm persists and cannot be reset.

If set up accordingly, safety parameter **C181** permits to deactivate and reactivate the **ENABLE** function to restart the drive once the cause responsible for the alarm has disappeared.

**NOTE**

Factory setting does not reset alarms at power off. Alarms are stored and displayed at next power on and the drive is locked. A manual reset is then required to unlock the drive (see the AUTORESET MENU).

**CAUTION**

If an alarm trips, see the ALARMS AND WARNINGS section and reset the equipment after detecting the cause responsible for the alarm.

**DANGER!!!**

Electrical shock hazard exists on output terminals (U, V, W) and resistive braking module terminals (+, -, B) even when the drive is disabled.

**NOTE**

Set **C154** = Yes to remove the reset function from MDI3. After that, only one different function can be allocated to MDI3 even when multiprogramming is active (see parameter **C182**).

## 37.2. Factory-setting of the Digital Inputs

---

Table 93: Terminal board: Factory-setting

| Function     | Terminal   | Description                      |
|--------------|------------|----------------------------------|
| START        | 14: MDI1   | Enables the drive RUN            |
| ENABLE       | 15: MDI2&S | Enables the drive                |
| RESET        | 16: MDI3   | Resets the alarms tripped        |
| MULTISPEED 0 | 17: MDI4   | Bit 0 for Multispeed selection   |
| MULTISPEED 1 | 18: MDI5   | Bit 1 for Multispeed selection   |
| Source Sel   | 19: MDI6   | Source Selection                 |
| Loc/Rem      | 20: MDI7   | Local / Remote Control Selection |
| CW/CCW       | 21: MDI8   | Reference reversal               |

### 37.3. List of Parameters C149 to C188c and I006

The parameters ranging from **C149** to **C180** and from **C186** to **C188c** (one for each command function) activate single functions and set the terminal for each enabling/disabling function.

Parameter **C181** enables a safe **START** mode.

Parameter **C182** enables multiple programming (if compatible) to the same terminal. Max. two functions can be programmed to the same input.

**Table 94: List of parameters C149 to C188c and I006**

| Parameter    | FUNCTION                                     | User Level  | MODBUS Address | Default Values     |
|--------------|--|-------------|----------------|--------------------|
| <b>I006</b>  | Function selection for MDI control           | ADVANCED    | 1393           | inactive           |
| <b>C149</b>  | START Input                                  | ADVANCED    | 1149           | MDI1               |
| <b>C149a</b> | START Input B                                | ADVANCED    | 1297           | none               |
| <b>C150</b>  | STOP Input                                   | ADVANCED    | 1150           | none               |
| <b>C150a</b> | STOP B Input                                 | ADVANCED    | 1298           | none               |
| <b>C151</b>  | REVERSE Input                                | ADVANCED    | 1151           | none               |
| <b>C151a</b> | REVERSE B Input                              | ADVANCED    | 1299           | none               |
| <b>C152</b>  | ENABLE-SW Input                              | ADVANCED    | 1152           | none               |
| <b>C153</b>  | DISABLE Input                                | ADVANCED    | 1153           | none               |
| <b>C154</b>  | Disable RESET alarms on MDI3                 | ADVANCED    | 1154           | NO                 |
| <b>C155</b>  | MULTISPEED 0 Input                           | ADVANCED    | 1155           | MDI4               |
| <b>C156</b>  | MULTISPEED 1 Input                           | ADVANCED    | 1156           | MDI5               |
| <b>C157</b>  | MULTISPEED 2 Input                           | ADVANCED    | 1157           | none               |
| <b>C158</b>  | MULTISPEED 3 Input                           | ADVANCED    | 1158           | none               |
| <b>C159</b>  | CW/CCW Input                                 | ADVANCED    | 1159           | MDI8               |
| <b>C160</b>  | DCB Input                                    | ADVANCED    | 1160           | none               |
| <b>C161</b>  | UP Input                                     | ADVANCED    | 1161           | none               |
| <b>C162</b>  | DOWN Input                                   | ADVANCED    | 1162           | none               |
| <b>C163</b>  | RESET UP/DOWN Input                          | ADVANCED    | 1163           | none               |
| <b>C164</b>  | External alarm 1 Input                       | ADVANCED    | 1164           | none               |
| <b>C164a</b> | External alarm 1 trip delay                  | ADVANCED    | 1305           | immediate          |
| <b>C165</b>  | External alarm 2 Input                       | ADVANCED    | 1165           | none               |
| <b>C165a</b> | External alarm 2 trip delay                  | ADVANCED    | 1306           | immediate          |
| <b>C166</b>  | External alarm 3 Input                       | ADVANCED    | 1166           | none               |
| <b>C166a</b> | External alarm 3 trip delay                  | ADVANCED    | 1307           | immediate          |
| <b>C167</b>  | MultiRamp 0 Input                            | ENGINEERING | 1167           | none               |
| <b>C168</b>  | MultiRamp 1 Input                            | ENGINEERING | 1168           | none               |
| <b>C169</b>  | JOG Input                                    | ADVANCED    | 1169           | none               |
| <b>C170</b>  | SLAVE Input                                  | ADVANCED    | 1170           | none               |
| <b>C171</b>  | PID DISABLE Input                            | ADVANCED    | 1171           | none               |
| <b>C171a</b> | Input for PID control selection              | ENGINEERING | 1188           | none               |
| <b>C172</b>  | KEYPAD LOCK Input                            | ADVANCED    | 1172           | none               |
| <b>C173</b>  | MOTOR 2 SEL. Input                           | ENGINEERING | 1173           | none               |
| <b>C174</b>  | MOTOR 3 SEL. Input                           | ENGINEERING | 1174           | none               |
| <b>C175</b>  | SPEED VAR. 0 Input                           | ENGINEERING | 1175           | none               |
| <b>C176</b>  | SPEED VAR. 1 Input                           | ENGINEERING | 1176           | none               |
| <b>C177</b>  | SPEED VAR. 2 Input                           | ENGINEERING | 1177           | none               |
| <b>C178</b>  | PID RESET UP/DOWN input                      | ADVANCED    | 1178           | none               |
| <b>C179</b>  | SOURCE SELECTION Input                       | ADVANCED    | 1179           | MDI6               |
| <b>C180</b>  | LOC/REM Input                                | ADVANCED    | 1180           | MDI7               |
| <b>C180a</b> | Type of LOC/REM contact                      | ADVANCED    | 1303           | pushbutton+storage |
| <b>C181</b>  | Safety Start enable                          | ADVANCED    | 1181           | inactive           |
| <b>C182</b>  | Multiprogramming enable                      | ENGINEERING | 1182           | inactive           |
| <b>C183</b>  | Max. fluxing time before drive Disable       | ADVANCED    | 1183           | disabled           |
| <b>C184</b>  | Fluxing at activation only with START closed | ADVANCED    | 1184           | no                 |
| <b>C184a</b> | Disable external torque limit during fluxing | ENGINEERING | 1200           | No                 |
| <b>C185</b>  | Stop Mode                                    | ADVANCED    | 1185           | deceleration ramp  |
| <b>C186</b>  | Fire Mode enabling Input                     | ENGINEERING | 1186           | none               |

| Parameter | FUNCTION                                 | User Level  | MODBUS Address | Default Values |
|-----------|--|-------------|----------------|----------------|
| C187      | Torque Limit Source Ref. Disabling Input | ADVANCED    | 1187           | none           |
| C188a     | PID Multireference 1 Input               | ENGINEERING | 1365           | none           |
| C188b     | PID Multireference 2 Input               | ENGINEERING | 1366           | none           |
| C188c     | PID Multireference 3 Input               | ENGINEERING | 1367           | none           |



**NOTE**

If a parameter is set to zero, its function is disabled, otherwise the parameter value stands for the MDIx input assigned to the function.



**NOTE**

Auxiliary digital inputs XMDI (values from 17 to 24 in control function parameters) can be set up only after setting XMDI/O in parameter **R023**.



**CAUTION**

Set **C182=1** to allocate 2 functions to the same terminal.

**I006 Function Selection for MDI Control**

|             |                 |   |  |
|-------------|-----------------|---|--|
| <b>I006</b> | <b>Range</b>    | 0 ÷ 2   | 0 → Inactive<br>1 → Clear all<br>2 → Set factory default |
|             | <b>Default</b>  | This is not a programming parameter: the input is set to zero whenever the drive is powered on and whenever the command is executed.                              |  |
|             | <b>Level</b>    | ADVANCED  |  |
|             | <b>Address</b>  | 1393  |  |
|             | <b>Function</b> | 0 → Inactive.<br>1 → Forces to “0 → Inactive” the settings of all the digital inputs.<br>2 → Forces to the default values the settings of all the digital inputs. |  |

**C149 START Input**

|             |                 |   |   |
|-------------|-----------------|---|---|
| <b>C149</b> | <b>Range</b>    | 0 ÷ 16<br>0 ÷ 24 if ES847 or ES870 is fitted  | 0 → Inactive<br>1 ÷ 8 → MDI1 ÷ MDI8<br>9 ÷ 12 → MPL1 ÷ MPL4<br>13 ÷ 16 → TFL1 ÷ TFL4<br>17 ÷ 24 → XMDI1 ÷ XMDI8 |
|             | <b>Default</b>  | 1   | MDI1  |
|             | <b>Level</b>    | ADVANCED  |   |
|             | <b>Address</b>  | 1149  |   |
|             | <b>Function</b> | When the <b>START</b> input is <b>activated</b> (the <b>ENABLE-A</b> and <b>ENABLE-B</b> inputs are activated as well), <b>RUN</b> is enabled: the speed (torque) <i>setpoint</i> increases following the programmed ramp until it reaches the active <i>reference</i> . In IFD control mode, <u>the main speed reference shall be other than zero for <b>RUN</b> enable.</u><br>When the <b>START</b> input is <b>inactive</b> (even if the <b>ENABLE-A</b> and <b>ENABLE-B</b> inputs are activated) <b>RUN</b> is disabled: the reference is set to zero and the speed (torque) <i>setpoint</i> drops to zero based on the programmed deceleration ramp. |   |



**NOTE**

If the PROFIdrive option is present, parameter **C149 START Input** must be assigned to value 1: MDI1.

**C149a START B Input**

|              |                 |   |   |
|--------------|-----------------|---|---|
| <b>C149a</b> | <b>Range</b>    | 0 ÷ 16<br>0 ÷ 24 if ES847 or ES870 is fitted  | 0 → Inactive<br>1 ÷ 8 → MDI1 ÷ MDI8<br>9 ÷ 12 → MPL1 ÷ MPL4<br>13 ÷ 16 → TFL1 ÷ TFL4<br>17 ÷ 24 → XMDI1 ÷ XMDI8 |
|              | <b>Default</b>  | 0   | Inactive  |
|              | <b>Level</b>    | ADVANCED  |   |
|              | <b>Address</b>  | 1297  |   |
|              | <b>Function</b> | The <b>START B</b> input behaves as the <b>START</b> input (see the START section) when terminal board B is active. |   |

**C150 STOP Input**

|             |                 |   |   |
|-------------|-----------------|---|---|
| <b>C150</b> | <b>Range</b>    | 0 ÷ 16<br>0 ÷ 24 if ES847 or ES870 is fitted  | 0 → Inactive<br>1 ÷ 8 → MDI1 ÷ MDI8<br>9 ÷ 12 → MPL1 ÷ MPL4<br>13 ÷ 16 → TFL1 ÷ TFL4<br>17 ÷ 24 → XMDI1 ÷ XMDI8 |
|             | <b>Default</b>  | 0   | Inactive  |
|             | <b>Level</b>    | ADVANCED  |   |
|             | <b>Address</b>  | 1150  |   |
|             | <b>Function</b> | <p>This parameter disables the <b>RUN</b> function enabled by the <b>START</b> command.</p> <p>The setting of this function affects the enabling/disabling mode of the <b>RUN</b> command: it can be enabled/disabled using the <b>START and STOP keys</b> or the <b>START, STOP and REVERSE keys</b> instead of the <b>START</b> key as <b>an ON/OFF switch</b> (factory-setting).</p> <p>If the drive is enabled:<br/>Press <b>START</b> to enable the drive <b>RUN</b>;<br/>Press <b>STOP</b> to disable the drive <b>RUN</b>: reference is set to zero, so the speed (or torque) setpoint decreases to zero based on the preset deceleration ramp.</p> <p>In case of preset <b>STOP</b>, the keypad and one or more terminal boards may be enabled at a time. In this case, the <b>START</b> key and the <b>STOP</b> key in the display/keypad are active and can enable or disable the drive <b>RUN</b>.</p> <p>The <b>STOP</b> input is a normally closed input signal.</p> |   |



**NOTE**

According to factory setting, only the hardware terminal board selected with command source 1 (**C140**=1) is active as a switch-operated mode (**C150**=0). To switch to the key-operated mode, set the **STOP** input (**C150** ≠ 0). The keypad and other terminal boards may be selected in key-operated mode only. If the **STOP** input is is not programmed, and the switch-operated mode is active, the keypad may be selected as the only command source (**C140**=5, **C141**=0, **C142** =0).



**NOTE**

The **STOP** function has priority over the **START** function; if both inputs are active, the **STOP** input prevails. Therefore, the **STOP** input acts as a key and as a **switch**.



**NOTE**

The **START/STOP** commands are ignored when the drive is disabled.

**C150a STOP B Input**

|              |                 |   |  |
|--------------|-----------------|---|--|
| <b>C150a</b> | <b>Range</b>    | 0 ÷ 16<br>0 ÷ 24 if ES847 or ES870 is fitted  | 0 → Inactive,<br>1 ÷ 8 → MDI1 ÷ MDI8<br>9 ÷ 12 → MPL1 ÷ MPL4<br>13 ÷ 16 → TFL1 ÷ TFL4<br>17 ÷ 24 → XMDI1 ÷ XMDI8 |
|              | <b>Default</b>  | 0   | Inactive   |
|              | <b>Level</b>    | ADVANCED  |  |
|              | <b>Address</b>  | 1298  |  |
|              | <b>Function</b> | The <b>STOP B</b> Input acts as the <b>STOP</b> Input (see <b>C150</b> ) when Terminal Board B is active.<br><br>The <b>STOP B</b> is a normally closed input signal. |  |

**C151 REVERSE Input**

|             |                 |  |   |
|-------------|-----------------|--|---|
| <b>C151</b> | <b>Range</b>    | 0 ÷ 16<br>0 ÷ 24 if ES847 or ES870 is fitted   | 0 → Inactive<br>1 ÷ 8 → MDI1 ÷ MDI8<br>9 ÷ 12 → MPL1 ÷ MPL4<br>13 ÷ 16 → TFL1 ÷ TFL4<br>17 ÷ 24 → XMDI1 ÷ XMDI8 |
|             | <b>Default</b>  | 0  | Inactive  |
|             | <b>Level</b>    | ADVANCED   |   |
|             | <b>Address</b>  | 1151   |   |
|             | <b>Function</b> | The <b>REVERSE</b> function carries out a <b>START</b> command, but it reverses the motor direction of rotation.<br>If both the <b>START</b> and <b>REVERSE</b> inputs are active at the same time, the drive is sent a <b>STOP</b> command.<br>If the <b>STOP</b> input function is not programmed ( <b>C150=0</b> ), the <b>REVERSE</b> signal and the <b>START</b> input act as switches, otherwise they act as keys. |   |



**NOTE**

If the keypad is active, pressing the **FWD/REV** key on the display/keypad will also reverse the direction of rotation of the connected motor.  
The reference direction of rotation can be reversed with **Cw/CCw** if this is set up (**C159 ≠ 0**).  
Both functions cause a signal reversal; if they are both active, they will cancel each other.



**NOTE**

The keypad and the terminal board can be simultaneously activated only if the **STOP (C150 ≠ 0)** function is activated. Three sources for the signal reversal are then active: **REVERSE, Cw/CCw, REV** key; if two of them are active, they will cancel each other, while if all three sources are active, the reference sign will be reversed.



**CAUTION**

When the reference sign is reversed, the direction of rotation of the connected motor is not immediately reversed: the setpoint decreases to zero following the preset deceleration ramp, and it increases up to the reference value having the opposite sign following the preset acceleration ramp.

**C151a REVERSE B Input**

|              |                 |   |   |
|--------------|-----------------|---|---|
| <b>C151a</b> | <b>Range</b>    | 0 ÷ 16<br>0 ÷ 24 if ES847 or ES870 is fitted  | 0 → Inactive<br>1 ÷ 8 → MDI1 ÷ MDI8<br>9 ÷ 12 → MPL1 ÷ MPL4<br>13 ÷ 16 → TFL1 ÷ TFL4<br>17 ÷ 24 → XMDI1 ÷ XMDI8 |
|              | <b>Default</b>  | 0   | Inactive  |
|              | <b>Level</b>    | ADVANCED  |   |
|              | <b>Address</b>  | 1299  |   |
|              | <b>Function</b> | The <b>REVERSE B</b> Input acts as the <b>REVERSE</b> Input (see <b>C151</b> ) when Terminal Board B is active. |   |

The figure below illustrates the processing logic diagram for the **START**, **REV**, **Cw/CCw** functions and the **START**, **STOP**, **REV** keys on the display/keypad if the **STOP** function is not programmed.

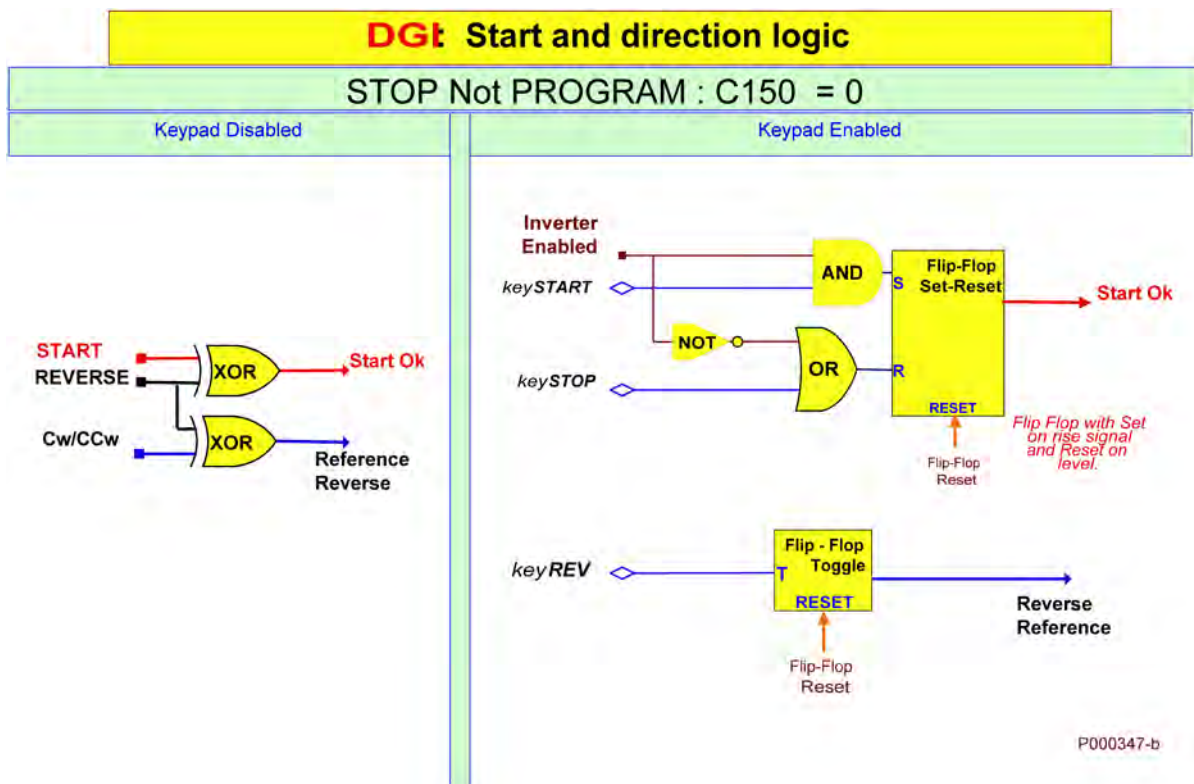

Figure 49: Controlling Run and Direction when the STOP Input is not programmed

The figure below illustrates the processing logic diagram for the **START, REV, Cw/CCw** functions and the **START, STOP, REV** keys on the display/keypad, if the **STOP** function is programmed.

**DG1: Start and direction logic**

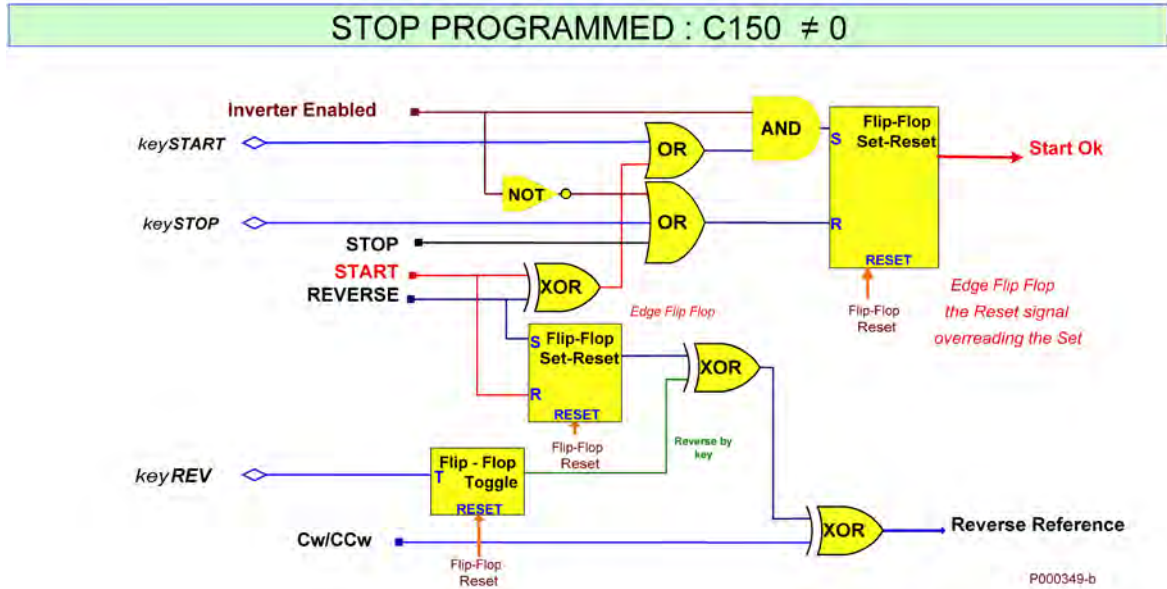

Figure 50: Controlling Run and Direction when the STOP Input is programmed

**C152 ENABLE-SW Input**

|             |                 |  |   |
|-------------|-----------------|--|---|
| <b>C152</b> | <b>Range</b>    | 0 ÷ 16<br>0 ÷ 24 if ES847 or ES870 if fitted   | 0 → Inactive<br>1 ÷ 8 → MDI1 ÷ MDI8<br>9 ÷ 12 → MPL1 ÷ MPL4<br>13 ÷ 16 → TFL1 ÷ TFL4<br>17 ÷ 24 → XMDI1 ÷ XMDI8 |
|             | <b>Default</b>  | 0  | Inactive  |
|             | <b>Level</b>    | ADVANCED   |   |
|             | <b>Address</b>  | 1152   |   |
|             | <b>Function</b> | <p>This is an additional software-controlled Enable signal which is estimated in series to the <b>ENABLE</b> function associated to <b>MDI2</b> inputs. If this function is enabled, the drive is enabled <i>if and only if</i> the <b>ENABLE-A</b>, <b>ENABLE-B</b> and <b>ENABLE-SW</b> inputs are simultaneously activated.</p> <p>If the <b>ENABLE-SW</b> function is programmed (<b>C152</b>≠0), do the following to enable the drive:</p> <ul style="list-style-type: none"> <li>activate the <b>ENABLE-SW</b> signal</li> <li>activate the <b>ENABLE-A</b> and <b>ENABLE-B</b> signals</li> <li>activate <b>MDI2</b> inputs via serial link and fieldbus, if those inputs are selected via <b>C140</b>, <b>C141</b>, <b>C142</b>.</li> <li>activate the <b>DISABLE</b> signal if programmed via <b>C153</b>.</li> </ul> |   |



**NOTE**

The **ENABLE-SW** signal may not be delayed by the timers: if a timer is programmed to the terminal related to the **ENABLE-SW** signal, this will not affect the **ENABLE-SW** function, while it normally delays other functions set to the same terminal.



**DANGER!!!**

The deactivation of the **ENABLE-SW** signal, the activation of the **DISABLE** signal, the deactivation of **MDI2** inputs from serial link or fieldbus DO NOT GUARANTEE that the Safe Torque Off – STO function is removed from the motor connected to the drive. Safety stop conditions are guaranteed only when at least one of the two **ENABLE-A** and **ENABLE-B** inputs are opened.  
For more details, consult the Safe Torque Off Function - Application Manual.

**C153 DISABLE Input**

|             |                      |  |   |
|-------------|----------------------|--|---|
| <b>C153</b> | <b>Range</b>         | 0 ÷ 16<br>0 ÷ 24 if ES847 or ES870 is fitted   | 0 → Inactive<br>1 ÷ 8 → MDI1 ÷ MDI8<br>9 ÷ 12 → MPL1 ÷ MPL4<br>13 ÷ 16 → TFL1 ÷ TFL4<br>17 ÷ 24 → XMDI1 ÷ XMDI8 |
|             | <b>Default Level</b> | 0  | Inactive  |
|             | <b>Address</b>       | 1153   |   |
|             | <b>Function</b>      | <p>The <b>DISABLE</b> function disables the drive and overrides any <b>ENABLE-A</b> and <b>ENABLE-B</b> signals.</p> <p>The <b>DISABLE</b> command sets the drive output voltage to zero, so the motor starts idling (the motor idles and stops due to friction or the mechanical load).</p> <p>If the <b>DISABLE</b> function is set up (<b>C153</b>≠0), do the following to enable the drive:</p> <ul style="list-style-type: none"> <li>• deactivate the input signal on the terminal selected via <b>C153</b></li> <li>• activate the <b>ENABLE-A</b> and <b>ENABLE-B</b> signals</li> <li>• activate the <b>MDI2</b> inputs via serial link and fieldbus, if selected via <b>C140</b>, <b>C141</b>, <b>C142</b></li> <li>• activate the <b>ENABLE-SW</b> signal if programmed via <b>C152</b>.</li> </ul> |   |



**DANGER!!!**

The deactivation of the **ENABLE-SW** signal, the activation of the **DISABLE** signal, the deactivation of **MDI2** inputs from serial link or fieldbus DO NOT GUARANTEE that the Safe Torque Off – STO function is removed from the motor connected to the drive. Safety stop conditions are guaranteed only when at least one of the two **ENABLE-A** and **ENABLE-B** inputs are opened.  
For more details, consult the Safe Torque Off Function - Application Manual.

**C154 Disable RESET Alarms on MDI3**

|             |                 |   |                |
|-------------|-----------------|---|----------------|
| <b>C154</b> | <b>Range</b>    | 0 ÷ 1   | 0: NO ; 1: Yes |
|             | <b>Default</b>  | 0   | 0: NO          |
|             | <b>Level</b>    | ADVANCED  |                |
|             | <b>Address</b>  | 1154  |                |
|             | <b>Function</b> | If <b>C154 =1</b> : <b>Yes</b> , the alarm reset function can be disabled from MDI3, that can be assigned to other functions. |                |

**C155, C156, C157, C158 MULTISPEED Inputs**

|                                |   |  |   |
|--------------------------------|---|--|---|
| <b>C155 C156<br/>C157 C158</b> | Range   | 0 ÷ 16<br>0 ÷ 24 if ES847 or ES870 is fitted   | 0 → Inactive<br>1 ÷ 8 → MDI1 ÷ MDI8<br>9 ÷ 12 → MPL1 ÷ MPL4<br>13 ÷ 16 → TFL1 ÷ TFL4<br>17 ÷ 24 → XMDI1 ÷ XMDI8 |
|                                | Default   | <b>C155 = 4, C156 = 5, C157 = 0, C158 = 0.</b> | <b>C155 = MDI4, C156 = MDI5, C157 = C158 = Inactive.</b>  |
|                                | Level   | ADVANCED                                       |   |
|                                | Address   | 1155, 1156, 1157, 1158                         |   |
| Function                       | This function generates up to <u>15 speed references</u> that can be programmed with parameters <b>P081+P098</b> according to the programming mode set in <b>P080</b> .<br><br>The 4 Multispeed functions determine which of the 15 active speed references are active: active value ( <b>1</b> ) or inactive value ( <b>0</b> ) of each preset input signal determines a bit-logic binary number: <b>MULTISPEED 0</b> is the less significant bit (bit 0) and <b>MULTISPEED 3</b> is the most significant bit (bit 3).<br><br>If one of these functions is not set up, its relevant bit is “zero”. |  |   |

**Table 95: Multispeed selection**

|                       |              |              |              |              |
|-----------------------|--------------|--------------|--------------|--------------|
| Multispeed selected = | Bit 3        | Bit 2        | Bit 1        | Bit 0        |
|                       | MULTISPEED 3 | MULTISPEED 2 | MULTISPEED 1 | MULTISPEED 0 |

**Table 96: Selected Speed reference**

| Function:           | Status of the relevant input |     |      |      |      |      |      |      |      |      |      |      |      |      |      |      |      |
|---------------------|------------------------------|-----|------|------|------|------|------|------|------|------|------|------|------|------|------|------|------|
| START               | 0                            | 1   | 1    | 1    | 1    | 1    | 1    | 1    | 1    | 1    | 1    | 1    | 1    | 1    | 1    | 1    |      |
| MULTISPEED 0        | X                            | 0   | 1    | 0    | 1    | 0    | 1    | 0    | 1    | 0    | 1    | 0    | 1    | 0    | 1    | 0    |      |
| MULTISPEED 1        | X                            | 0   | 0    | 1    | 1    | 0    | 0    | 1    | 1    | 0    | 0    | 1    | 1    | 0    | 0    | 1    |      |
| MULTISPEED 2        | X                            | 0   | 0    | 0    | 0    | 1    | 1    | 1    | 1    | 0    | 0    | 0    | 0    | 1    | 1    | 1    |      |
| MULTISPEED 3        | X                            | 0   | 0    | 0    | 0    | 0    | 0    | 0    | 0    | 1    | 1    | 1    | 1    | 1    | 1    | 1    |      |
| Multispeed selected | X                            | 0   | 1    | 2    | 3    | 4    | 5    | 6    | 7    | 8    | 9    | 10   | 11   | 12   | 13   | 14   | 15   |
| Resulting reference | 0                            | (*) | P081 | P083 | P085 | P087 | P088 | P089 | P090 | P091 | P092 | P093 | P094 | P095 | P096 | P097 | P098 |

If one of these functions is not set up, its relevant bit is “zero”.  
 For example, if **C156** and **C157** are Inactive (0), while **C155** and **C158** are programmed to two different terminals, only Multispeed 0, 1, 8, 9 can be selected, relating to the following references:

|     |      |      |      |
|-----|------|------|------|
| (*) | P081 | P091 | P092 |
|-----|------|------|------|

(\*) Factory-setting: (**P080 = Preset Speed**) if no Multispeed function is selected, the active reference is the reference set according to the parameters in the INPUTS FOR REFERENCES MENU.  
 If **P080 = Speed Sum**, the selected Multispeed function **adds up** to the active reference: the reference set according to the parameters in the INPUTS FOR REFERENCES MENU.  
 If **P080 = Preset Speed Esc**, the selected Multispeed **replaces** the active reference, which will be ignored. If no Multispeed function is selected, the resulting reference is equal to zero.  
 See also the INPUTS FOR REFERENCES MENU for the reference processing sequence: the **Speed Decrease** function and the **Reference Reversal** function become active downstream of the **Multispeed** function.



**NOTE**

In Table 96:  
 0 ⇒ Inactive input;  
 1 ⇒ Active input;  
 X ⇒ Input having no effect.

**C159 CW/CCW Input**

|             |                 |   |   |
|-------------|-----------------|---|---|
| <b>C159</b> | <b>Range</b>    | 0 ÷ 16<br>0 ÷ 24 if ES847 or ES870 is fitted  | 0 → Inactive<br>1 ÷ 8 → MDI1 ÷ MDI8<br>9 ÷ 12 → MPL1 ÷ MPL4<br>13 ÷ 16 → TFL1 ÷ TFL4<br>17 ÷ 24 → XMDI1 ÷ XMDI8 |
|             | <b>Default</b>  | 8   | MDI8  |
|             | <b>Level</b>    | ADVANCED  |   |
|             | <b>Address</b>  | 1159  |   |
|             | <b>Function</b> | The <b>CW/CCW</b> function reverses the <b>active reference signal</b> : the connected motor decelerates to zero following the preset deceleration ramp, then it accelerates following the preset acceleration ramp until it reaches the new reference value. |   |

**C160 DCB Input**

|                 |  |  |   |
|-----------------|--|--|---|
| <b>C160</b>     | <b>Range</b>   | 0 ÷ 16<br>0 ÷ 24 if ES847 or ES870 is fitted | 0 → Inactive<br>1 ÷ 8 → MDI1 ÷ MDI8<br>9 ÷ 12 → MPL1 ÷ MPL4<br>13 ÷ 16 → TFL1 ÷ TFL4<br>17 ÷ 24 → XMDI1 ÷ XMDI8 |
|                 | <b>Default</b>   | 0  | Inactive  |
|                 | <b>Level</b>   | ADVANCED                                     |   |
|                 | <b>Address</b>   | 1160   |   |
|                 | <b>Control</b>   | IFD and VTC                                  |   |
| <b>Function</b> | For other types of control, this function has no effect even if <b>C160</b> ≠0.<br>The DCB command enables <b>DC braking</b> for a time period depending on the speed value determining the input activation.<br>See the DC BRAKING MENU for more details. |  |   |

**C161, C162 UP and DOWN Inputs**

|                  |                 |  |   |
|------------------|-----------------|--|---|
| <b>C161 C162</b> | <b>Range</b>    | 0 ÷ 16<br>0 ÷ 24 if ES847 or ES870 is fitted   | 0 → Inactive<br>1 ÷ 8 → MDI1 ÷ MDI8<br>9 ÷ 12 → MPL1 ÷ MPL4<br>13 ÷ 16 → TFL1 ÷ TFL4<br>17 ÷ 24 → XMDI1 ÷ XMDI8 |
|                  | <b>Default</b>  | 0  | Inactive  |
|                  | <b>Level</b>    | ADVANCED   |   |
|                  | <b>Address</b>  | 1161, 1162   |   |
|                  | <b>Function</b> | This function increases ( <b>UP</b> ) or decreases ( <b>DOWN</b> ) the reference for which the <b>UpDown source from MDI has been selected</b> by adding a quantity to the reference itself. This also depends upon the following parameters:<br><b>C163</b> Up/Down Reset<br><b>P067</b> Up/Down Ramp Time<br><b>P068</b> Store Up/Down value at power off<br><b>P068a</b> Speed/Torque Up/Down Reset at stop<br><b>P068b</b> PID Up/Down Reset at stop<br><b>P068c</b> Speed/Torque Up/Down Reset at sources changeover<br><b>P068d</b> PID Up/Down Reset at sources changeover<br><b>P069</b> Up/Down Reference range |   |

**C163 Reset Up/Down Input for Speed/Torque Reference**

|             |                 |  |   |
|-------------|-----------------|--|---|
| <b>C163</b> | <b>Range</b>    | 0 ÷ 16<br>0 ÷ 24 if ES847 or ES870 is fitted   | 0 → Inactive<br>1 ÷ 8 → MDI1 ÷ MDI8<br>9 ÷ 12 → MPL1 ÷ MPL4<br>13 ÷ 16 → TFL1 ÷ TFL4<br>17 ÷ 24 → XMDI1 ÷ XMDI8 |
|             | <b>Default</b>  | 0  | Inactive  |
|             | <b>Level</b>    | ADVANCED   |   |
|             | <b>Address</b>  | 1163   |   |
|             | <b>Function</b> | This function sets to zero the reference <b>variation</b> obtained via the <b>UP</b> or <b>DOWN</b> inputs or the ▲ and ▼ keys located on the display/keypad. The Up/Down reference (Speed/Torque only) may also be reset using different functions (see <b>P068a – P068c</b> ). |   |

**C164 , C165, C166 External Alarm Inputs**

|                               |                 |  |   |
|-------------------------------|-----------------|--|---|
| <b>C164<br/>C165<br/>C166</b> | <b>Range</b>    | 0 ÷ 16<br>0 ÷ 24 if ES847 or ES870 is fitted   | 0 → Inactive<br>1 ÷ 8 → MDI1 ÷ MDI8<br>9 ÷ 12 → MPL1 ÷ MPL4<br>13 ÷ 16 → TFL1 ÷ TFL4<br>17 ÷ 24 → XMDI1 ÷ XMDI8 |
|                               | <b>Default</b>  | 0  | Inactive  |
|                               | <b>Level</b>    | ADVANCED   |   |
|                               | <b>Address</b>  | 1164, 1165, 1166   |   |
|                               | <b>Function</b> | When allocating one of these 3 functions to a digital input, the status of this input will <b>ALWAYS BE CHECKED ON THE DRIVE'S TERMINAL BOARD</b> .<br><u>When the command contact opens</u> , the drive is locked due to an alarm tripped. Parameters <b>C164a, C165a, C166a</b> allow delaying external alarms. To restart the drive, the digital input set as an external alarm must be closed and a Reset procedure is required. Alarms tripped due to these 3 functions are <b>A083, A084, A085</b> respectively. This function is factory set as disabled. |   |



**CAUTION**

The terminal board for these 3 functions is the hardware terminal board of the drive. If different command sources are enabled (see the CONTROL METHOD MENU), the “External Alarm” signal command is obtained only for the hardware terminal board of the drive. Therefore, in order to avoid any external alarm, the input signal for the active terminal must be active in the terminal board. Alarms trip when only one input signal for the terminal selected on one of the active command sources is disabled. A trip delay can be programmed with parameters **C164a, C165a, C166a**.

**C164a (C165a, C166a) External Alarm Trip Delay**

|                                  |                 |  |                |
|----------------------------------|-----------------|--|----------------|
| <b>C164a<br/>C165a<br/>C166a</b> | <b>Range</b>    | 0 ÷ 32000  | 0 ÷ 32000 msec |
|                                  | <b>Default</b>  | 0  | Instantaneous  |
|                                  | <b>Level</b>    | ADVANCED   |                |
|                                  | <b>Address</b>  | 1305, 1306, 1307   |                |
|                                  | <b>Function</b> | External alarm trip delay. To avoid untimely alarm trip, it may be necessary to set a check time for the opening of the input set as an external alarm before the alarm trips. |                |

**C167, C168 MULTIRAMP Inputs**

|                  |                      |  |   |
|------------------|----------------------|--|---|
| <b>C167 C168</b> | <b>Range</b>         | 0 ÷ 16<br>0 ÷ 24 if ES847 or ES870 is fitted   | 0 → Inactive<br>1 ÷ 8 → MDI1 ÷ MDI8<br>9 ÷ 12 → MPL1 ÷ MPL4<br>13 ÷ 16 → TFL1 ÷ TFL4<br>17 ÷ 24 → XMDI1 ÷ XMDI8 |
|                  | <b>Default Level</b> | 0  | Inactive  |
|                  | <b>Address</b>       | ENGINEERING  |   |
|                  | <b>Address</b>       | 1167, 1168   |   |
|                  | <b>Function</b>      | <p>This function allows selecting up to <b>4 acceleration/deceleration ramps</b>. Each ramp has its own programming parameters; see <b>P009 ÷ P025 (RAMPS MENU)</b>.<br/>                 These 2 functions determine which of the 4 ramps is to be selected: the active value (<b>1</b>) or inactive value (<b>0</b>) of each preset input signal determines a binary number with a bit-logic, where <b>Multiramp 0</b> is the less significant bit (bit 0 ) and <b>Multiramp 1</b> is the most significant bit (bit 1).<br/> <b>The ramps range from 1 to 4; for the selected ramp, add 1 to the binary figure obtained.</b><br/>                 If one of these functions is not programmed, the relevant bit is “zero”.</p> |   |

**Table 97: Multiramp selection**

$$\text{Selected Ramp} = ( \begin{matrix} \text{Bit 1} \\ \text{Multiramp 1} \end{matrix} \begin{matrix} \text{Bit 0} \\ \text{Multiramp 0} \end{matrix} ) + 1$$

**Table 98: Selected ramp**

| Function:   | Input Status                |                             |                             |                             |
|---|-----------------------------|-----------------------------|-----------------------------|-----------------------------|
| Multiramp 0   | 0                           | 1                           | 0                           | 1                           |
| Multiramp 1   | 0                           | 0                           | 1                           | 1                           |
| <b>Selected Ramp</b>                                      | <b>1</b>                    | <b>2</b>                    | <b>3</b>                    | <b>4</b>                    |
| Active ramp times (parameters determining the ramp model) | P009<br>P010<br>P014<br>(*) | P012<br>P013<br>P014<br>(*) | P015<br>P016<br>P020<br>(*) | P018<br>P019<br>P020<br>(*) |

If one of these functions is not programmed, its bit is “zero”.  
 For example, if **C167** is Inactive (0) and **C168** is programmed for one terminal, only ramp 1 or ramp 3 can be selected.



**NOTE (\*)**

If the ramp rounding off function is enabled (**P021≠0**), the real ramp times also depend on the values set in parameters **P022, P023, P024, P025, P031**.

**C169 JOG Input**

|             |                 |   |   |
|-------------|-----------------|---|---|
| <b>C169</b> | <b>Range</b>    | 0 ÷ 16<br>0 ÷ 24 if ES847 or ES870 is fitted  | 0 → Inactive<br>1 ÷ 8 → MDI1 ÷ MDI8<br>9 ÷ 12 → MPL1 ÷ MPL4<br>13 ÷ 16 → TFL1 ÷ TFL4<br>17 ÷ 24 → XMDI1 ÷ XMDI8 |
|             | <b>Default</b>  | 0   | Inactive  |
|             | <b>Level</b>    | ADVANCED  |   |
|             | <b>Address</b>  | 1169  |   |
|             | <b>Function</b> | When the JOG function is enabled, the motor rotates at low speed following slow ramps which are manually controlled by the user only by means of the keys in keypad. If the drive is enabled ( <b>ENABLE</b> function activated) but is not running, and if the JOG terminal is enabled, the drive will run: the connected motor will accelerate following a JOG ramp ( <b>P029</b> ) up to the JOG speed reference ( <b>P070</b> ). On the other hand, if the terminal is disabled, the drive will stop: the connected motor will decelerate to zero speed following the JOG ramp ( <b>P029</b> ).<br>Reverse the direction of rotation of the active reference to reverse the <b>JOG</b> reference. |   |



**CAUTION**

The motor starts running as soon as this terminal is activated (only if the drive is enabled).



**NOTE**

The **RUN** function will override the **JOG** function. Therefore, if the **RUN** function is active, the **JOG** function is ignored.



**NOTE**

If the motor is not running in **SLAVE mode** (torque reference instead of speed reference), it can rotate at JOG speed when the user activates the **JOG** function. In **SLAVE mode**, the **JOG** function is ignored if the motor is still rotating due to an active reference torque.

**C170 SLAVE Input**

|             |                 |  |   |
|-------------|-----------------|--|---|
| <b>C170</b> | <b>Range</b>    | 0 ÷ 16<br>0 ÷ 24 if ES847 or ES870 is fitted   | 0 → Inactive<br>1 ÷ 8 → MDI1 ÷ MDI8<br>9 ÷ 12 → MPL1 ÷ MPL4<br>13 ÷ 16 → TFL1 ÷ TFL4<br>17 ÷ 24 → XMDI1 ÷ XMDI8 |
|             | <b>Default</b>  | 0  | Inactive  |
|             | <b>Level</b>    | ADVANCED   |   |
|             | <b>Address</b>  | 1170   |   |
|             | <b>Control</b>  | VTC and FOC  |   |
|             | <b>Function</b> | When activating the terminal allocated to the Slave Input, the main reference becomes a torque reference and the speed loop is by-passed. This function enables the <b>SLAVE</b> operating mode ( <b>torque reference</b> ), instead of the <b>MASTER</b> operating mode (speed reference); the <u>Torque References</u> and the <u>Ramp Torques</u> are used (see the INPUTS FOR REFERENCES MENU and the RAMPS MENU). |   |



**NOTE**

This function is ignored if the operating mode selected for the active motor is the *SLAVE* mode, i.e. **C011**=1 or 2 (motor 1), **C054**=1 or 2 (motor 2), **C097**=1 or 2 (motor 3). Commands are factory-set to *MASTER* mode and the speed reference is selected as factory setting (**C011**= 0 ; **C054** =0 ; **C097** = 0).

**C171 PID DISABLE Input**

|             |                 |  |   |
|-------------|-----------------|--|---|
| <b>C171</b> | <b>Range</b>    | 0 ÷ 16<br>0 ÷ 24 if ES847 or ES870 is fitted   | 0 → Inactive<br>1 ÷ 8 → MDI1 ÷ MDI8<br>9 ÷ 12 → MPL1 ÷ MPL4<br>13 ÷ 16 → TFL1 ÷ TFL4<br>17 ÷ 24 → XMDI1 ÷ XMDI8 |
|             | <b>Default</b>  | 0  | Inactive  |
|             | <b>Level</b>    | ADVANCED   |   |
|             | <b>Address</b>  | 1171   |   |
|             | <b>Function</b> | <p>This function is used for managing the PID regulator (see the PID CONFIGURATION MENU).</p> <p>When the terminal allocated to this function is activated, the <u>PID regulator can be disabled</u>: its output and its external variable are set to zero.</p> <p>More precisely, if the PID regulator is in <b>External Out</b> mode (<b>C294</b>=0), when the <b>PID DISABLE</b> function is enabled, the PID output is set to zero and the external variable regulated by the PID regulator (feedback) <u>is no longer regulated by the PID regulator itself</u>.</p> <p>In Reference mode, the <b>PID DISABLE</b> function <u>disables the PID regulator</u> as described above and <b>switches the reference</b>, thus becoming the main active reference again.</p> |   |

**C171a Input for PID Control Selection**

|              |                 |  |   |
|--------------|-----------------|--|---|
| <b>C171a</b> | <b>Range</b>    | 0 ÷ 16<br>0 ÷ 24 if ES847 or ES870 is fitted   | 0 → Inactive<br>1 ÷ 8 → MDI1 ÷ MDI8<br>9 ÷ 12 → MPL1 ÷ MPL4<br>13 ÷ 16 → TFL1 ÷ TFL4<br>17 ÷ 24 → XMDI1 ÷ XMDI8 |
|              | <b>Default</b>  | 0  | Inactive  |
|              | <b>Level</b>    | ENGINEERING  |   |
|              | <b>Address</b>  | 1188   |   |
|              | <b>Function</b> | <p>This parameter pertains to the activation of the two PIDs or the 2-zone mode (see the PID CONFIGURATION MENU).</p> <p>It allows using the PID regulator outputs in different ways and allows disabling the 2-zone mode.</p> |   |

**C172 KEYPAD LOCK Input**

|             |                 |   |   |
|-------------|-----------------|---|---|
| <b>C172</b> | <b>Range</b>    | 0 ÷ 16<br>0 ÷ 24 if ES847 or ES870 is fitted  | 0 → Inactive<br>1 ÷ 8 → MDI1 ÷ MDI8<br>9 ÷ 12 → MPL1 ÷ MPL4<br>13 ÷ 16 → TFL1 ÷ TFL4<br>17 ÷ 24 → XMDI1 ÷ XMDI8 |
|             | <b>Default</b>  | 0   | Inactive  |
|             | <b>Level</b>    | ADVANCED  |   |
|             | <b>Address</b>  | 1172  |   |
|             | <b>Function</b> | This function <b>avoids accessing parameter modification</b> through the removable display/keypad and <b>avoids accessing the LOCAL mode</b> by pressing the <b>LOC/REM</b> key or by enabling the <b>LOCAL</b> input function ( <b>C181</b> ). |   |



**NOTE**

If the **LOCAL** mode is already active, the **LOCK** command will have no effect on the **LOCAL** function: it only avoids changing the programming parameters, while it is still possible to send references and the **START/STOP/REV/JOG/RESET** commands via keypad.

If the **LOCK** command is active and the **LOCAL mode** is disabled, the **LOCK** function prevents the LOCAL mode from activating.

**C173, C174 MOTOR SEL Input**

|                      |                 |  |   |
|----------------------|-----------------|--|---|
| <b>C173<br/>C174</b> | <b>Range</b>    | 0 ÷ 16<br>0 ÷ 24 if ES847 or ES870 is fitted   | 0 → Inactive<br>1 ÷ 8 → MDI1 ÷ MDI8<br>9 ÷ 12 → MPL1 ÷ MPL4<br>13 ÷ 16 → TFL1 ÷ TFL4<br>17 ÷ 24 → XMDI1 ÷ XMDI8 |
|                      | <b>Default</b>  | 0  | Inactive  |
|                      | <b>Level</b>    | ENGINEERING  |   |
|                      | <b>Address</b>  | 1173, 1174   |   |
|                      | <b>Function</b> | This function <b>activates motor 2 and 3</b> and sets the relevant programming parameters (see Table 99).<br>A different active motor can be selected only when the drive is disabled. |   |

**Table 99: Motor selection**

| Value of the terminal allocated to the <b>Sel. Motor n.2 (C173)</b> function | Value of the terminal allocated to the <b>Sel. Motor n.3 (C174)</b> function | Active motor     |
|--|--|------------------|
| 0  | 0  | <b>Motor n.1</b> |
| 1  | 0  | <b>Motor n.2</b> |
| 0  | 1  | <b>Motor n.3</b> |
| 1  | 1  | <b>Motor n.1</b> |



**NOTE**

When both inputs are enabled, Motor 1 is selected again.

**C175, C176, C177 SPEED VAR. Inputs**

|                               |                 |  |   |
|-------------------------------|-----------------|--|---|
| <b>C175<br/>C176<br/>C177</b> | <b>Range</b>    | 0 ÷ 16<br>0 ÷ 24 if ES847 or ES870 is fitted   | 0 → Inactive<br>1 ÷ 8 → MDI1 ÷ MDI8<br>9 ÷ 12 → MPL1 ÷ MPL4<br>13 ÷ 16 → TFL1 ÷ TFL4<br>17 ÷ 24 → XMDI1 ÷ XMDI8 |
|                               | <b>Default</b>  | 0  | Inactive  |
|                               | <b>Level</b>    | ENGINEERING  |   |
|                               | <b>Address</b>  | 1175, 1176, 1177   |   |
|                               | <b>Function</b> | This function generates up to 7 values of variation % for the active reference ranging from -100% to 100% with parameters <b>P115÷P121</b> .<br>The 3 functions determine which of the 7 values of the speed reference variation is active: the active value (1) or inactive value (0) of each preset input signal determines a bit-logic binary number where <b>SPEED VAR. 0</b> is the less significant bit (bit 0), while <b>SPEED VAR. 2</b> is the most significant bit (bit 3) as shown in Table 100 and Table 101.<br>If one of these functions is not set up, its bit is "zero". |   |

**Table 100: Selection of the speed reference variation**

|   |                   |                   |                   |
|---|-------------------|-------------------|-------------------|
| Variation of the Selected Speed Reference = | Bit 2             | Bit 1             | Bit 0             |
|   | SPEED VARIATION 2 | SPEED VARIATION 1 | SPEED VARIATION 0 |

**Table 101: Variation of the selected speed reference**

| Function:                                 | Input Status |      |      |      |      |      |      |      |
|---|--------------|------|------|------|------|------|------|------|
| MULTISPEED 0                              | 0            | 1    | 0    | 1    | 0    | 1    | 0    | 1    |
| MULTISPEED 1                              | 0            | 0    | 1    | 1    | 0    | 0    | 1    | 1    |
| MULTISPEED 2                              | 0            | 0    | 0    | 0    | 1    | 1    | 1    | 1    |
| Variation of the selected speed reference | None         | 1    | 2    | 3    | 4    | 5    | 6    | 7    |
| Variation % selected                      | 0            | P115 | P116 | P117 | P118 | P119 | P120 | P121 |

If one of the functions above is not set up, its bit is "zero".

For example, if **C175** and **C177** are INACTIVE (0) and **C176** is programmed for one terminal, only variation 2 corresponding to parameter **P116** can be selected.

In any case, the output speed must never exceed the max. allowable speed, even when a higher speed is required.



**NOTE**

In Table 101 above:  
 0 ⇒ Inactive Input;  
 1 ⇒ Active Input.

**C178 PID Up/Down Reset Input**

|             |                 |   |   |
|-------------|-----------------|---|---|
| <b>C178</b> | <b>Range</b>    | 0 ÷ 16<br>0 ÷ 24 if ES847 or ES870 is fitted  | 0 → Inactive<br>1 ÷ 8 → MDI1 ÷ MDI8<br>9 ÷ 12 → MPL1 ÷ MPL4<br>13 ÷ 16 → TFL1 ÷ TFL4<br>17 ÷ 24 → XMDI1 ÷ XMDI8 |
|             | <b>Default</b>  | 0   | Inactive  |
|             | <b>Level</b>    | ADVANCED  |   |
|             | <b>Address</b>  | 1178  |   |
|             | <b>Function</b> | This function <b>resets</b> the variation of the PID reference obtained with the ▲ and ▼ keys on the KEYPAD page of the user interface on the display/keypad in PID mode. |   |

**C179 Source Selection Input**

|             |                 |  |   |
|-------------|-----------------|--|---|
| <b>C179</b> | <b>Range</b>    | 0 ÷ 16<br>0 ÷ 24 if ES847 or ES870 is fitted   | 0 → Inactive<br>1 ÷ 8 → MDI1 ÷ MDI8<br>9 ÷ 12 → MPL1 ÷ MPL4<br>13 ÷ 16 → TFL1 ÷ TFL4<br>17 ÷ 24 → XMDI1 ÷ XMDI8 |
|             | <b>Default</b>  | 6  | MDI6  |
|             | <b>Level</b>    | ADVANCED   |   |
|             | <b>Address</b>  | 1179   |   |
|             | <b>Function</b> | <p>The digital input set as a source selector is <b>considered in the drive terminal board only</b>, not in the virtual terminal boards, as Fieldbus or Serial Link (see Command Sources).</p> <p>When the digital input set as a source selector is <u>open</u>, only the first command sources and references programmed in the CONTROL METHOD MENU are considered (<b>C140</b> command source n.1 and <b>C143</b> reference source n.1 respectively) as well as the first reference and feedback sources programmed in the PID CONFIGURATION MENU (parameter <b>C285</b> for reference source n. 1 and <b>C288</b> for feedback source n.1).</p> <p>When the digital input set as a source selector is <u>closed</u>, only the second command source and the second reference source programmed in the CONTROL METHOD MENU are considered (<b>C141</b> for command source n. 2 and <b>C144</b> for reference source n.2), as well as the second reference sources and feedback sources set in the PID CONFIGURATION MENU (parameter <b>C286</b> for reference source n.2 and parameter C289 for feedback source n.2).</p> |   |



**CAUTION**

If set different from 0:Disabled, reference sources n.3 (**C145** in the CONTROL METHOD MENU and **C287** and **C290** in the PID CONFIGURATION MENU) and reference sources n.4 (**C146** in the CONTROL METHOD MENU) are always considered as summed up to the reference source selected by the source selector.

**C180 LOC/REM Input**

|             |                      |   |   |
|-------------|----------------------|---|---|
| <b>C180</b> | <b>Range</b>         | 0 ÷ 16<br>0 ÷ 24 if ES847 or ES870 is fitted  | 0 → Inactive<br>1 ÷ 8 → MDI1 ÷ MDI8<br>9 ÷ 12 → MPL1 ÷ MPL4<br>13 ÷ 16 → TFL1 ÷ TFL4<br>17 ÷ 24 → XMDI1 ÷ XMDI8 |
|             | <b>Default Level</b> | 7   | MDI7  |
|             | <b>Address</b>       | 1180  |   |
|             | <b>Function</b>      | <p>The digital input set as a source selector is <b>considered in the drive terminal board only</b>, not in the virtual terminal boards, as Fieldbus or Serial Link (see Command Sources).</p> <p>The <b>LOCAL mode</b> can be enabled via the relevant digital input (it ignores any enabling/disable delay times set via software timers) or by pressing the <b>LOC/REM</b> key located on the display/keypad.</p> <p>Factory setting allows enabling the Local mode only when the drive is not running. Settings may be changed through <b>C148 Changeover from Remote to Local Command</b> (see the CONTROL METHOD MENU); switching from Remote to Local command is allowed even when the drive is operating and when the running condition or reference must be maintained in Local mode.</p> <p>This function allows switching over to <b>LOCAL mode</b> and allows ignoring parameters <b>C140 to C147</b> and <b>C285 to C287</b> (see the PID CONFIGURATION MENU) when the PID controller is enabled, <b>thus allowing setting them via KEYPAD only</b>.</p> <p>The following functions are still active in the hardware terminal board of the control board being used: <b>ENABLE, External Alarm 1,2,3, Sel.Motor n.2, Sel.Motor n.3, SLAVE, PID Disable</b>, and <b>the LOCAL function itself</b>, that can be disabled at any time. If the input is deactivated when the drive is disabled, signals coming from different sources will activate again.</p> <p>If the main reference of the drive is the PID output, you can set <b>C180a Type of LOC/REM Contact = Pushbutton</b> and <b>P266 Type of Keypad page in Local Mode = Ref.Activated + Spd</b>. As a result, when the <b>Loc</b> key is pressed and released once, the drive enters the Local mode and the PID reference can be changed, whereas when the <b>Loc</b> command is pressed and released again (provided that the drive is not enabled) the PID is disabled and the RPM reference can be sent to the connected motor. See also the CONTROL METHOD MENU and the Keypad page and Local mode in the DISPLAY/KEYPAD menu.</p> |   |

**C180a Type of LOC/REM Contact**

|              |                      |  |  |
|--------------|----------------------|--|--|
| <b>C180a</b> | <b>Range</b>         | 0 ÷ 2  | 0:[Switch]<br>1:[Pushbutton]<br>2:[Pushbutton+Storage] |
|              | <b>Default Level</b> | 2  | 2:[Pushbutton+Storage]                                 |
|              | <b>Address</b>       | 1303   |  |
|              | <b>Function</b>      | <p>Factory-setting: the digital contact set as LOC/REM (<b>C180</b>) is Pushbutton based.</p> <p>If the PID output is the main reference and <b>P266 Type of Keypad Page in Local Mode = Ref.Activated + Spd</b>, allowing entering the LOCAL mode when the LOC/REM command is first sent, thus controlling the PID reference, and allowing the LOCAL mode to be maintained when the LOC/REM command is sent for the second time, thus disabling the PID and allowing setting a speed reference, the LOC/REM digital input must be set as <b>C180a=Pushbutton</b>.</p> <p>If <b>C180a=2</b>, the logic status of <b>LOC/REM</b> will be saved at power off and will be used when the drive is next powered on.</p> |  |

**C181 Safety Start**

|             |                 |  |                  |
|-------------|-----------------|--|------------------|
| <b>C181</b> | <b>Range</b>    | 0 ÷ 1  | Inactive, Active |
|             | <b>Default</b>  | 0  | Inactive         |
|             | <b>Level</b>    | ADVANCED   |                  |
|             | <b>Address</b>  | 1181   |                  |
|             | <b>Function</b> | This function <b>enables</b> the <b>Safety START mode</b> .<br>When this function is enabled and the drive is to be restarted after resetting an alarm, <u>open and close</u> the <b>ENABLE-A</b> and <b>ENABLE-B</b> terminals.<br>This prevents the drive from RUNNING when it is turned off and on again (for example after a mains loss) and the <b>START</b> and <b>ENABLE-A</b> and <b>ENABLE-B</b> inputs are on. |                  |



**NOTE**

If multiple terminal boards are selected with parameters **C140**, **C141**, **C142**, open and close the **MDI2** terminals in one of the active terminal boards to restart the drive.

**C182 Multiprogramming Enable**

|             |                 |   |                  |
|-------------|-----------------|---|------------------|
| <b>C182</b> | <b>Range</b>    | 0 ÷ 1   | Inactive, Active |
|             | <b>Default</b>  | 1   | Inactive         |
|             | <b>Level</b>    | ENGINEERING   |                  |
|             | <b>Address</b>  | 1182  |                  |
|             | <b>Function</b> | This function allows allocating two different functions to the same terminal. |                  |



**NOTE**

Only few preset combinations are allowed.  
 When invalid configurations are set up, "ILLEGAL DATA" appears on the display/keypad of the Penta drive.

**C183 Max. Fluxing Time Before Drive Disable**

|             |                 |   |              |
|-------------|-----------------|---|--------------|
| <b>C183</b> | <b>Range</b>    | 0 ÷ 65000   | 0 ÷ 65000 ms |
|             | <b>Default</b>  | 0   | Disabled     |
|             | <b>Level</b>    | ADVANCED  |              |
|             | <b>Address</b>  | 1183  |              |
|             | <b>Control</b>  | VTC and FOC   |              |
|             | <b>Function</b> | This function disables the drive if the fluxing time period is longer than the preset time (if the <b>ENABLE</b> function, not a <b>START</b> command, is active).<br>To restore motor fluxing, disable and enable the <b>ENABLE</b> function, or if with the active <b>ENABLE</b> function a <b>START</b> command is also activated. |              |



**NOTE**

The time set in C183 is added to the Fluxing Ramp Time set in **C041** / **C084** / **C127**.

**C184 Fluxing at Activation only with START Closed**

|             |                 |  |              |
|-------------|-----------------|--|--------------|
| <b>C184</b> | <b>Range</b>    | 0 ÷ 1  | 0:No - 1:Yes |
|             | <b>Default</b>  | 0  | 0:No         |
|             | <b>Level</b>    | ADVANCED   |              |
|             | <b>Address</b>  | 1184   |              |
|             | <b>Control</b>  | VTC and FOC  |              |
|             | <b>Function</b> | Fluxing may be carried out only when the <b>START</b> command is closed. |              |

**C184a Disable External Torque Limit During Fluxing**

|              |                 |  |             |
|--------------|-----------------|--|-------------|
| <b>C184a</b> | <b>Range</b>    | 0 ÷ 1  | 0:NO; 1:Yes |
|              | <b>Default</b>  | 0  | 0:NO        |
|              | <b>Level</b>    | ENGINEERING  |             |
|              | <b>Address</b>  | 1200   |             |
|              | <b>Control</b>  | FOC  |             |
|              | <b>Function</b> | During the fluxing stage, until the desired flux value is attained, the external torque limit (if any) set in <b>C147</b> is disabled (see CONTROL METHOD MENU). During that stage, only the limits set in <b>C047</b> and <b>C048</b> (see LIMITS MENU) are applied. This function is useful to limit undesired motor operation—due to residual rotor magnetization—during the fluxing stage. |             |

**C185 STOP Mode**

|             |                 |  |   |
|-------------|-----------------|--|---|
| <b>C185</b> | <b>Range</b>    | 0 ÷ 1  | 0: [Deceleration Ramp] – 1:[Free Wheel] |
|             | <b>Default</b>  | 0  | 0: [Deceleration Ramp]                  |
|             | <b>Level</b>    | ADVANCED   |   |
|             | <b>Address</b>  | 1185   |   |
|             | <b>Function</b> | This function allows selecting whether the drive is to be deactivated with a controlled deceleration ramp or is left idling when the <b>START</b> command is open. |   |

**C186 Fire Mode Enable Input**

|             |                 |  |   |
|-------------|-----------------|--|---|
| <b>C186</b> | <b>Range</b>    | 0 ÷ 16<br>0 ÷ 24 if ES847 or ES870 is fitted   | 0 → Inactive<br>1 ÷ 8 → MDI1 ÷ MDI8<br>9 ÷ 12 → MPL1 ÷ MPL4<br>13 ÷ 16 → TFL1 ÷ TFL4<br>17 ÷ 24 → XMDI1 ÷ XMDI8 |
|             | <b>Default</b>  | 0  | Inactive  |
|             | <b>Level</b>    | ENGINEERING  |   |
|             | <b>Address</b>  | 1186   |   |
|             | <b>Function</b> | This parameter allows programming a digital input to activate the Fire Mode (see the Fire Mode section). |   |

**C187 Torque Limit Source Ref. Disable Input**

|             |                 |   |   |
|-------------|-----------------|---|---|
| <b>C187</b> | <b>Range</b>    | 0 ÷ 16<br>0 ÷ 24 if ES847 or ES870 is fitted  | 0 → Inactive<br>1 ÷ 8 → MDI1 ÷ MDI8<br>9 ÷ 12 → MPL1 ÷ MPL4<br>13 ÷ 16 → TFL1 ÷ TFL4<br>17 ÷ 24 → XMDI1 ÷ XMDI8 |
|             | <b>Default</b>  | 0   | Inactive  |
|             | <b>Level</b>    | ADVANCED  |   |
|             | <b>Address</b>  | 1187  |   |
|             | <b>Function</b> | This function sets a digital input allowing disabling the external torque limit. When the digital input set for <b>C187</b> is active, the torque limit will depend on the parameters contained in the LIMITS MENU of the active motor. |   |

**C188a, C188b, C188c Inputs for PID MULTIREFERENCES**

|  |                 |   |   |
|--|-----------------|---|---|
| <b>C188a</b><br><b>C188b</b><br><b>C188c</b> | <b>Range</b>    | 0 ÷ 16<br>0 ÷ 24 if ES847 or ES870 is fitted  | 0 → Inactive<br>1 ÷ 8 → MDI1 ÷ MDI8<br>9 ÷ 12 → MPL1 ÷ MPL4<br>13 ÷ 16 → TFL1 ÷ TFL4<br>17 ÷ 24 → XMDI1 ÷ XMDI8 |
|  | <b>Default</b>  | 0   | Inactive  |
|  | <b>Level</b>    | ADVANCED  |   |
|  | <b>Address</b>  | 1365, 1366, 1367  |   |
|  | <b>Function</b> | This function allows generating up to <u>7 PID references</u> that can be programmed with parameters <b>P081a</b> to <b>P087a</b> according to the operating mode selected with <b>P080a</b> .<br><br>The 3 functions determine which is the active reference among the 7 available PID references: the active value (1) or the inactive value (0) of each programmed input signal determines a bit-logic value, where <b>MULTIREF 0</b> is the least significant bit (bit 0) and <b>MULTIREF 2</b> is the most significant bit (bit 2).<br>If one of the available functions is not programmed, the value of the relevant bit is “zero”. |   |

**Table 102: Selection of PID Multireferences**

|                           |                  |                  |                  |
|---------------------------|------------------|------------------|------------------|
| Multireference selected = | <b>Bit 2</b>     | <b>Bit 1</b>     | <b>Bit 0</b>     |
|                           | MULTIREFERENCE 2 | MULTIREFERENCE 1 | MULTIREFERENCE 0 |

## 38. ENCODER/FREQUENCY INPUTS MENU

### 38.1. Overview

---

Three quick acquisition digital inputs are available in the Sinus Penta control board:

- MDI6/ECHA/FINA;
- MDI7/ECHB;
- MDI8/FINB.

These inputs can be used as incremental encoder reading (encoder A) or as frequency inputs. In addition, if **ES836** or **ES913** optional board is used (see the Sinus Penta's Installation Guide), an additional encoder reading (encoder B) is allowed.



**NOTE** If **MDI6** and **MDI7** are used for encoder reading, only Push–Pull encoders can be used.



**NOTE** For the reversal of the incremental encoder speed measure, properly set up parameter **C199**.

#### 38.1.1. WHEN ES836 IS NOT USED

- **Incremental Encoder reading:**

Digital inputs **MDI6** and **MDI7** are used for reading the two channels of a 24V push–pull encoder powered directly by the Sinus Penta control board (see the Sinus Penta's Installation Guide).

No function can be programmed for **MDI6** and **MDI7**; if you attempt to program **MDI6** and **MDI7**, alarm **A082** Illegal Encoder Configuration will trip when the **ENABLE** function is activated.

- **Reading a Frequency Input:**

Digital inputs **MDI6** or **MDI8** can be used.

If **MDI6** is programmed as a frequency input (**FINA**) with **C189**, no other function can be programmed; otherwise, alarm **A100** MDI6 Illegal Configuration trips when the **ENABLE** function is activated.

If **MDI8** is programmed as a frequency input (**FINB**) with **C189**, no other function can be allocated to MDI8, and **ES836** or **ES913** optional board must not be applied to the power drive, otherwise, alarm **A101** MDI8 Illegal Configuration trips when the **ENABLE** function is activated.

- **Reading a Frequency Input and an Encoder:**

**MDI6** and **MDI7** are used to read the push–pull encoder, and **MDI8** is used to read the frequency input. The following alarms may trip:

- **A082** Illegal Encoder Configuration, if additional functions are allocated to **MDI6** or **MDI7**;
- **A101 MDI8** Illegal Configuration, if additional functions are allocated to **MDI8** or if the power drive detects the presence of **ES836** or **ES913** optional board.

## 38.1.2. WHEN USING ES836 OR ES913 OPTIONAL BOARD

### • Reading 1 or 2 Incremental Encoders:

To read one Encoder, use ES836 optional board or digital inputs **MDI6** and **MDI7** (if a push–pull encoder is used).

Both the optional board and digital inputs **MDI6** and **MDI7** can be used to read two encoders at a time. Use parameter **C189** to set the readout of the speed measure of the controlled motor or to read reference values.

You can use encoder **A** or encoder **B** as a speed feedback or a reference source (speed reference, torque reference or PID reference).

Example:

If you want to use encoder **A** as a speed reference source and encoder **B** as a speed feedback, set **C189** as 6:[A Ref ; B Fbk]; use **P073** and **P074** (INPUTS FOR REFERENCES MENU) to define the min. speed and the max. speed read for scaling and saturation of encoder **A** selected as a reference source (in one of parameters **C144 ÷ C147**, CONTROL METHOD MENU); set parameter **C012** (motor 1) to [Yes] to enable the Speed Feedback from Encoder function.

If encoder **A** is selected, no function can be programmed for **MDI6** and **MDI7**; otherwise, alarm **A082** Illegal Encoder Configuration will trip when the **ENABLE** function is activated.

If encoder **B** is selected and **ES836** or **ES913** optional board is not detected by the drive, alarm **A082** Illegal Encoder Configuration will trip when the **ENABLE** function is activated.

### • Reading a Frequency Input:

Only **MDI6** digital input (FINA) can be used as a frequency input; if **MDI8** is programmed as a frequency input (FINB) with **C189**, if the optional board is installed, alarm **A101 MDI8** Illegal Configuration trips.

No additional function must be assigned to **MDI6**; otherwise, alarm **A100 MDI6** Illegal Configuration will trip when the **ENABLE** function is activated.

### • Reading a Frequency Input and an Incremental Encoder:

**MDI6** Digital input (FINA) is used as a frequency input and Encoder **B** is used (because **ES836** or **ES913** board avoids reading frequency input FINB through **MDI8**).

If additional functions are programmed for digital input **MDI6**, alarm **A100 MDI6** Illegal Configuration will trip when **ENABLE** closes.

If alarm **A082** Illegal Encoder Configuration trips, this means that the drive has not detected **ES836** or **ES913** board (check the board wiring).

Parameter **C189** defines whether quick acquisition digital inputs are used to read a frequency input or an encoder, and if the encoder is a reference source or a feedback source.

In the **Encoder Menu**, you can also do the following:

- define the number of pls/rev for the encoder being used;
- enable or disable the speed alarm;
- define a time constant applied to read filtering;
- define whether encoders are read by means of quadrature channels or by channel **A** only (while the direction of rotation will be defined by channel **B**: ChB low level → negative rotation; ChB high level → positive rotation).

## 38.1.3. WHEN USING TWO ENCODERS

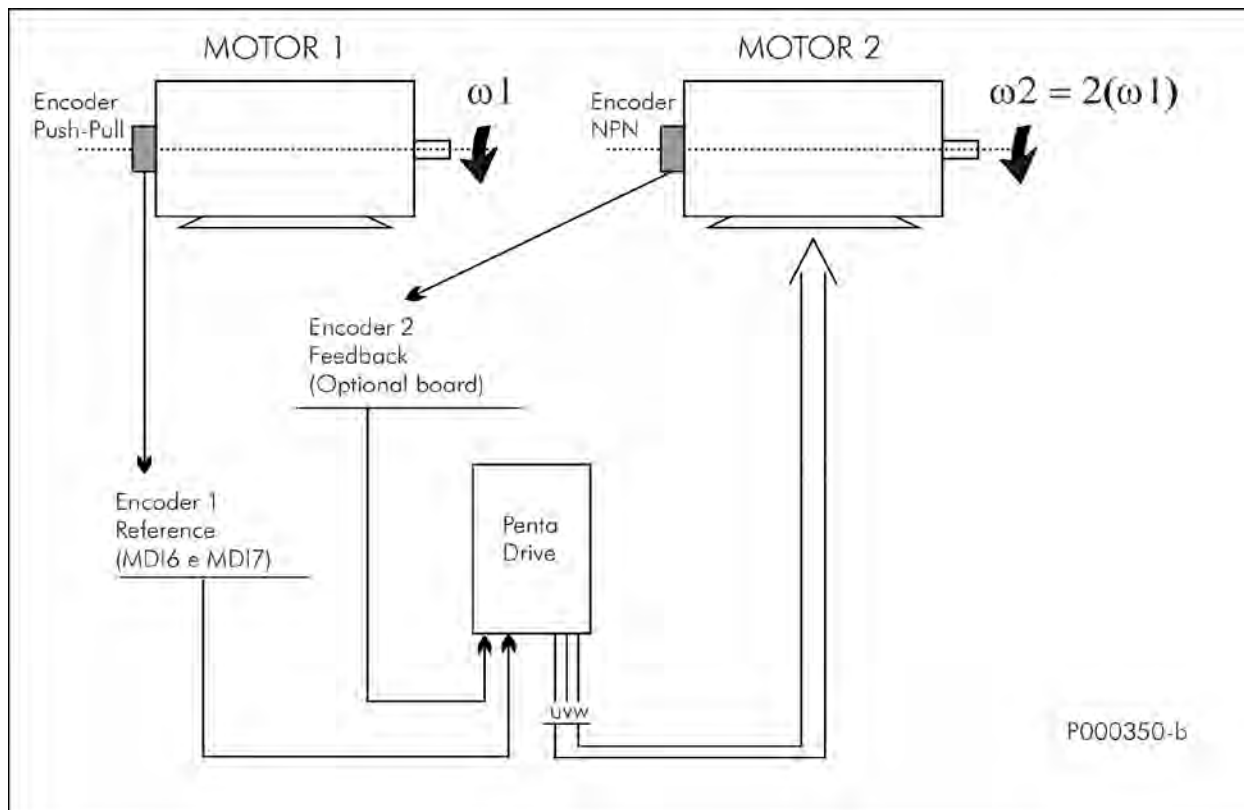

Figure 51: Using two encoders (example)

Suppose that motor 2 is to be controlled in closed chain and that its speed value is twice the speed value of motor 1. To do so, use speed of motor 1, provided with an encoder, as the reference for the Penta Drive, and use the speed measure of encoder B, which is coaxial to the motor controlled by the drive, as a speed feedback. Suppose that motor 1 speed ranges from 0 to 750rpm and that motor 1 is provided with a Push–Pull encoder with Single–Ended outputs and that its resolution is 2048 pls/rev.

Motor 2 is provided with an NPN encoder with Single–Ended outputs; its resolution is 1024 pls/rev. Only one Push–Pull encoder can be connected to digital inputs MDI6–MDI7, so encoder NPN of motor 2, representing the speed feedback of the drive, must be connected to ES836 board (drive Encoder B), whereas the encoder of motor 1 (Push–Pull), used as a reference, shall be connected to terminals MDI6 and MDI7 (drive Encoder A). Encoder Configuration is as follows:

**Encoder/Frequency Inputs Menu**

(operating modes and encoder feature setting)

|   |  |
|---|--|
| <b>C189</b> = [6: A–Reference B–Feedback] | (Encoder/Frequency input operating mode) |
| <b>C190</b> = 2048 pls/rev                | (Number of pls/rev for Encoder A)        |
| <b>C191</b> = 1024 pls/rev                | (Number of pls/rev for Encoder B)        |
| <b>C197</b> = [0: 2Ch.Quad.]              | (Number of channels of Encoder A)        |
| <b>C198</b> = [0: 2Ch.Quad.]              | (Number of channels of Encoder B)        |
| <b>C199</b> = [0: Fdbk.No Ref.No]         | (Encoder reading sign reversal)          |

**Motor Control 1 Menu**

(Setup of control mode with speed feedback from encoder and min. speed and max. speed of the controlled motor)

**C012** = [Yes] (Speed feedback from M1 encoder)  
**C028** = 0 rpm (Min. speed of motor M1)  
**C029** = 1500 rpm (Max. speed of motor M1)

**Control Method Menu**

(Setup of the source of the speed feedback from encoder)

**C143** = [8: Encoder] (Selection of reference 1 source)  
**C144** = [0: Disable ] (Selection of reference 2 source)  
**C145** = [0: Disable ] (Selection of reference 3 source)  
**C146** = [0: Disable ] (Selection of reference 4 source)

**References Menu**

(Setup of the reading range for the encoder used as a speed reference)

**P073** = 0 rpm (Encoder input min. rpm)  
**P074** = 750 rpm (Encoder input max. rpm)

**Ramps Menu**

(Ramps time applied to the reference are reset to maintain the desired speed variation without entering any delay value)

**P009** = 0 (Acceleration time 1)  
**P010** = 0 (Deceleration time 1)

When motor 1 reaches its max. speed (750rpm), the speed reference is 100% (because the speed value read by the encoder used as a reference source is saturated and scaled with respect to the min. rpm and max. rpm set in P073, P074). Because the max. speed of the motor controlled by the drive is 1500 rpm (C029), the speed reference is 1500 rpm.

## 38.2. List of Parameters C189 to C199

Table 103: List of parameters C189 to C199

| Parameter | FUNCTION  | User Level  | MODBUS Address | DEFAULT VALUES          |
|-----------|---|-------------|----------------|-------------------------|
| C189      | Encoder/Frequency input operating mode                    | BASIC       | 1189           | 0 [Not used, Not used]  |
| C190      | Number of pls/rev for encoder A                           | BASIC       | 1190           | 1024                    |
| C191      | Number of pls/rev for encoder B                           | BASIC       | 1191           | 1024                    |
| C192      | Speed searching error timeout                             | ENGINEERING | 1192           | 5.00 sec                |
| C193      | Error between reference and speed                         | ENGINEERING | 1193           | 300 rpm                 |
| C194      | Tracking error alarm enable                               | ENGINEERING | 1194           | 1: Active               |
| C195      | Filter time constant over value of feedback from encoder  | ENGINEERING | 1195           | 5.0 ms                  |
| C196      | Filter time constant over value of reference from encoder | ENGINEERING | 1196           | 5.0 ms                  |
| C197      | Number of channels of Encoder A                           | ENGINEERING | 1197           | 0:2 Quadrature channels |
| C198      | Number of channels of Encoder B                           | ENGINEERING | 1198           | 0:2 Quadrature channels |
| C199      | Encoder sign reversal                                     | ENGINEERING | 1199           | 0[Fdbk.NO;Ref.NO]       |

### C189 Encoder/Frequency Input Operating Mode

|             |                 |  |                        |
|-------------|-----------------|--|------------------------|
| <b>C189</b> | <b>Range</b>    | 0 ÷ 14   | See Table 104          |
|             | <b>Default</b>  | 0  | 0 [Not used; Not used] |
|             | <b>Level</b>    | BASIC  |                        |
|             | <b>Address</b>  | 1189   |                        |
|             | <b>Function</b> | <p>This parameter determines the operating mode of the fast acquisition digital inputs or the encoders connected to the optional boards. If MDI8 is used as a frequency input, the optional board for encoder B is not required. MDI6 digital input may be used as a frequency input; if used along with MDI7, it can be used for encoder A reading.</p> <p>Reading both encoders A and B can be programmed; parameter <b>C189</b> defines the encoder to be used as a reference source (if set as a speed/torque reference source in the MOTOR CONFIGURATION MENU or as a PID reference source in the PID CONFIGURATION MENU) and the encoder to be used as a speed feedback.</p> <p>Configuration allowed for quick acquisition digital inputs is shown in Table 104.</p> <p><b>If the encoder is used as a reference source, the detected speed value will be saturated and scaled based on values set in P073 and P074 respectively (minimum and maximum value for the encoder).</b></p> <p><i>Example:</i><br/> <b>C189</b> [A Reference; B Unused], <b>P073</b> [-1500rpm], <b>P074</b> [1500rpm] if the encoder is used as a PID reference, the reference measure is expressed as a percentage of the max. value [ P073 ;  P074 ].</p> <p><b><u>If a frequency input is selected, its readout is saturated and scaled based on parameters P071 and P072 respectively (minimum and maximum value for the frequency input).</u></b></p> |                        |

Table 104: Coding of C189

| Value | When using Encoder A/FINA   | When using Encoder B/FINB   |
|-------|-----------------------------|-----------------------------|
| 0     | Not used                    | Not used                    |
| 1     | EncA Feedback               | Not used                    |
| 2     | EncA Reference              | Not used                    |
| 3     | Not used                    | EncB Feedback               |
| 4     | Not used                    | EncB Reference              |
| 5     | EncA Feedback               | EncB Reference              |
| 6     | EncA Reference              | EncB Feedback               |
| 7     | EncA Reference and Feedback | Not used                    |
| 8     | Not used                    | EncB Reference and Feedback |
| 9     | MDI6 Frequency Input        | Not used                    |
| 10    | Not used                    | MDI8 Frequency Input        |
| 11    | MDI6 Frequency Input        | EncB Reference              |
| 12    | EncA Reference              | MDI8 Frequency Input        |
| 13    | MDI6 Frequency Input        | EncB Feedback               |
| 14    | EncA Feedback               | MDI8 Frequency Input        |

Values 7-8: the same encoder can be used both as a reference source and as a reference feedback. Value 7: encoder A can be used both as a speed feedback for the motor control and as a PID regulator reference.

**C190 Number of Pls/Rev for Encoder A**

| C190 | Range    | 256 ÷ 10000  | 256 ÷ 10000 pls/rev |
|------|----------|--|---------------------|
|      | Default  | 1024   | 1024                |
|      | Level    | BASIC  |                     |
|      | Address  | 1190   |                     |
|      | Function | Defines the number of pls/rev for encoder A (encoder in the terminal board). |                     |

**C191 Number of Pls/Rev for Encoder B**

| C191 | Range    | 256 ÷ 10000  | 256 ÷ 10000 pls/rev |
|------|----------|--|---------------------|
|      | Default  | 1024   | 1024                |
|      | Level    | BASIC  |                     |
|      | Address  | 1191   |                     |
|      | Function | Defines the number of pls/rev for encoder B (encoder that can be connected to ES836 optional board). |                     |

**C192 Timeout for Speed Alarm**

| C192 | Range    | 0 ÷ 65000   | 0.00 ÷ 650.00 sec |
|------|----------|---|-------------------|
|      | Default  | 500   | 5.00 sec          |
|      | Level    | ENGINEERING   |                   |
|      | Address  | 1192  |                   |
|      | Function | If the speed alarm (C194) is enabled and the speed error exceeds the speed threshold (C193), this parameter determines the speed error timeout. Even if the alarm speed is disabled, time set in C192 and error threshold set in C193 are used to signal a speed searching error to digital outputs set with BRAKE or LIFT mode. Digital outputs are then disabled. |                   |

**C193 Speed Error Threshold**

|             |                 |   |               |
|-------------|-----------------|---|---------------|
| <b>C193</b> | <b>Range</b>    | 0 ÷ 32000   | 0 ÷ 32000 rpm |
|             | <b>Default</b>  | 300   | 300 rpm       |
|             | <b>Level</b>    | ENGINEERING   |               |
|             | <b>Address</b>  | 1193  |               |
|             | <b>Function</b> | If the speed alarm ( <b>C194</b> ) is enabled, this parameter determines the error threshold for the speed error timeout ( <b>C192</b> ). |               |

**C194 Tracking Error Enable**

|             |                 |   |  |
|-------------|-----------------|---|--|
| <b>C194</b> | <b>Range</b>    | 0 ÷ 2   | 0: Disabled<br>1: Enabled<br>2: Active, except for when in torque limiting |
|             | <b>Default</b>  | 1   | 1: Enabled   |
|             | <b>Level</b>    | ENGINEERING   |  |
|             | <b>Address</b>  | 1194  |  |
|             | <b>Function</b> | <p>This parameter enables the tracking error alarm (<b>A080</b>, Tracking error).</p> <p>1: Inactive: In case of tracking error, no alarm trips. The tracking error activation is indicated by digital signal D32 (see Table 47).</p> <p>2: Active: in case of tracking error, alarm <b>A080</b> trips.</p> <p>3: Active, except for when in torque limiting: same as value 2, but the “tracking error” alarm trips only if:</p> <p>a) a limit source is preset in <b>C147</b>;</p> <p>b) the preset limit is &lt;95% of the maximum torque value (parameter <b>C048</b>);</p> <p>c) the speed regulator output is in saturation mode due to the preset torque limits.</p> <p>If the tracking error is caused by saturation of the speed regulator due to external torque limit, no alarm trips. The tracking error activation is indicated by digital signal D32 (see Table 47).</p> |  |

**CAUTION**

If the “Tracking Error” alarm is disabled, but **C303**=Yes, the time set in **C192** and the error threshold in **C193** are implemented to manage the tracking error, that deactivates the digital outputs set in BRAKE, ABS BRAKE or ABS LIFT modes and, consequently, activates the electromechanical brake.

Vice versa, when **C303**=No, digital outputs BRAKE, ABS BRAKE or ABS LIFT are NOT deactivated.

**C195 Filter Time Constant over Value of Feedback from Encoder**

|             |                 |  |               |
|-------------|-----------------|--|---------------|
| <b>C195</b> | <b>Range</b>    | 0 ÷ 30000  | 5 ÷ 3000.0 ms |
|             | <b>Default</b>  | 50   | 5.0 ms        |
|             | <b>Level</b>    | ENGINEERING  |               |
|             | <b>Address</b>  | 1195   |               |
|             | <b>Function</b> | This parameter defines the time constant used for filtering the reading of the encoder used as a speed feedback. |               |

**C196 Filter Time Constant over Value of Reference from Encoder**

|             |                 |   |               |
|-------------|-----------------|---|---------------|
| <b>C196</b> | <b>Range</b>    | 0 ÷ 30000   | 5 ÷ 3000.0 ms |
|             | <b>Default</b>  | 50  | 5.0 ms        |
|             | <b>Level</b>    | ENGINEERING   |               |
|             | <b>Address</b>  | 1196  |               |
|             | <b>Function</b> | This parameter defines the time constant used for filtering the reading of the encoder used as a reference. |               |

**C197 Number of Channels of Encoder A**

|             |                 |   |   |
|-------------|-----------------|---|---|
| <b>C197</b> | <b>Range</b>    | 0 ÷ 1   | 0: 2 Quadrature Channels<br>1: Channel only |
|             | <b>Default</b>  | 0   | 0: 2 Quadrature Channels                    |
|             | <b>Level</b>    | ENGINEERING   |   |
|             | <b>Address</b>  | 1197  |   |
|             | <b>Function</b> | This parameter defines the number of channels used for encoder A reading. Factory-setting is 2 Quadrature channels. Speed can be read through one channel only (as for phonic wheel); channel 2 can define the direction of rotation (low level → negative rotation; high level → positive rotation). |   |

**C198 Number of Channels of Encoder B**

|             |                 |  |   |
|-------------|-----------------|--|---|
| <b>C198</b> | <b>Range</b>    | 0 ÷ 1  | 0: 2 Quadrature channels<br>1: Channel only |
|             | <b>Default</b>  | 0  | 0: 2 Quadrature channels                    |
|             | <b>Level</b>    | ENGINEERING  |   |
|             | <b>Address</b>  | 1198   |   |
|             | <b>Function</b> | This parameter defines the number of channels used for encoder B reading (see parameter <b>C197</b> ). |   |

**C199 Encoder Sign Reversal**

|             |                 |  |                       |
|-------------|-----------------|--|-----------------------|
| <b>C198</b> | <b>Range</b>    | 0 ÷ 3  | See Table 105         |
|             | <b>Default</b>  | 0  | 0 [Fdbk. NO; Ref. NO] |
|             | <b>Level</b>    | ENGINEERING  |                       |
|             | <b>Address</b>  | 1199   |                       |
|             | <b>Function</b> | This parameter permits to reverse the speed sign measured by encoder inputs. |                       |



**NOTE**

When tuning the encoder, the encoder sign used as feedback is automatically adjusted to the direction of rotation of the connected motor.

**Table 105: Coding of C199**

| Value | Feedback Encoder Sign Reversal | Reference Encoder Sign Reversal |
|-------|--------------------------------|---------------------------------|
| 0     | Fdbk. NO                       | Ref. NO                         |
| 1     | Fdbk. YES                      | Ref. NO                         |
| 2     | Fdbk. NO                       | Ref. YES                        |
| 3     | Fdbk. YES                      | Ref. YES                        |

## 39. BRAKING AND RAMP EXTENSION MENU

### 39.1. Overview

---

The Braking and Ramp Extension Menu enables the clamp transistor command and sets its max. duty cycle for the drive braking resistance. If no braking resistance is installed, promptness of the DC bus voltage control can be adjusted in order to avoid OVERVOLTAGE alarm, causing abrupt deceleration. Special parameters are available, enabling controlling actions to limit DC bus voltage increase due to motor load variation.

#### 39.1.1. BRAKING MODULE AND RAMP EXTENSION

To enable the clamp transistor command for the braking resistance, set **C210=[With resistor]**. In this operating mode, when DC bus voltage exceeds a preset threshold value depending on the drive voltage class, the clamp transistor closes in the braking resistor, so energy in excess is dissipated to the resistor and DC bus voltage does not exceed voltage ratings.

The max. duty cycle of the braking resistor is parameterized with **C212** and **C211**: maximum duty cycle ( $100 * T_{on} / (T_{on} + T_{off})$  [%] ) and maximum time of continuous supply ( $T_{on}$ ) respectively. If the braking resistor activation is  $T_{on} = C212$  , when this interval is over, the relevant command will be disabled for a time equal to  $T_{off} = (100 - C212) * C211 / C212$  [sec].

#### Example:

A lifting application featuring a Sinus Penta 0086 at 400V requires a braking resistor with a 50% duty cycle. The braking period is 30s. According to the tables in the “Braking Resistors” section (Installation Guide) the applicable braking resistor is 10Ω – 24 kW.

The max. continuous duty for said resistor is 62s: the braking period is then compatible with that rating. Otherwise, a higher rated resistor should be applied.

Parameter setting:

**C210=[With resistor]**.

**C211=30s**

**C212=50%**

Factory-setting assumes that no braking resistor is provided. In this case, **C210** sets promptness, with respect to variations of DC bus, for the deceleration ramp slowing-down, in order not to overload the bus capacitor bank.

If **C210** is set to zero in FOC control, overfluxing deceleration is performed. For the other controls with **C210=0**, deceleration slows down when given values of the bus voltage are reached (depending on the drive voltage class).

If **C210** is  $> 0$ , DC bus voltage is controlled by considering the derivative of the bus voltage. The higher the value in **C210**, the lower the values for voltage variation affecting deceleration ramp times.



#### NOTE

The clamp transistor is not commanded if the drive is supplied from a Regenerative source (see **C008 = xT Regen**, where x can be 2, 4, 5, or 6).

### 39.1.2. TORQUE LIMIT AND FREQUENCY INCREASE DUE TO OVERVOLTAGE

VTC and FOC controls: a special functionality is available, allowing reducing the resisting torque due to DC-bus voltage increase, in order to prevent the Overvoltage alarm from tripping. A PI regulator is implemented to keep DC voltage below a preset threshold, thus limiting the maximum value of the resisting torque. In FOC control, this function is enabled only if **C210**=0. The regulator may be controlled in VTC control only. Parameters **C213a** and **C213b** are the regulator's proportional gain and integral gain respectively. Parameter **C213c** sets the voltage threshold, that equals:

$$V_{th} = C213c * V_{unlock} / 100$$

where **Vunlock** depends on the drive voltage class and is typically higher than the voltage threshold activating the braking resistor.

Parameter **C213d** enables reducing the rotor flux when the regulator activates, thus further limiting the DC voltage increase.

**CAUTION**

The reduction of the resisting torque generated by the function above affects the speed control when the motor accelerates due to external causes. Consequently, it can happen that the motor accelerates and exceeds the maximum allowable value set in parameter **C029**.

IFD control only: parameter **C213** causes a step increase of the output frequency to limit the DC bus voltage increase due to an abrupt change (decrease) of the motor load torque.

## 39.2. List of Parameters C210 to C213d

Table 106: List of parameters C210 to C213d

| Parameter    | FUNCTION  | User Level  | MODBUS Address | DEFAULT VALUES            |
|--------------|---|-------------|----------------|---------------------------|
| <b>C210</b>  | Automatic extension of down ramp                  | ENGINEERING | 1210           | See Table 80 and Table 84 |
| <b>C211</b>  | Max. time of continuous supply                    | ENGINEERING | 1211           | 2.00sec                   |
| <b>C212</b>  | Duty Cycle Braking (Ton/(Toff+Ton))               | ENGINEERING | 1212           | 10%                       |
| <b>C213</b>  | Frequency Increase for Overvoltage Compensation   | ENGINEERING | 1279           | 0%                        |
| <b>C213a</b> | Torque Limit Proportional Gain due to Overvoltage | ENGINEERING | 1251           | 0.020                     |
| <b>C213b</b> | Torque Limit Integral Gain due to Overvoltage     | ENGINEERING | 1252           | 0.010                     |
| <b>C213c</b> | Voltage Reference for Torque Limit                | ENGINEERING | 1253           | 100.0%                    |
| <b>C213d</b> | Flux Limit due to Torque Limit Activation         | ENGINEERING | 1254           | 0.0%                      |

### C210 Automatic Extension of Down Ramp

| C210 | Range    | -1 ÷ 32000  | -0.01: (With Resistance); 320.00% |
|------|----------|---|-----------------------------------|
|      | Default  | See Table 80 and Table 84   |                                   |
|      | Level    | ENGINEERING   |                                   |
|      | Address  | 1210  |                                   |
|      | Function | If <b>C210 = [With Resistor]</b> , this parameter commands enabling resistor and DC bus relating to this operating condition, allowing dissipating energy regenerated from the motor. If no braking resistor is used, energy regenerated from the motor cannot be dissipated. In this condition, the down ramp is extended if the variation in DC bus voltage is too rapid or exceeds certain threshold values. Set a higher value in parameter <b>C210</b> for a more sensitive ramp extension (a lower rating of regenerated power allows obtaining longer ramps), thus avoiding overvoltage. |                                   |

Parameter **C210** decreases the DC bus voltage threshold setting the ramp extension. The k factor is as follows:  
 $k = P_{out} / (P_{max} * 100 * C210)$ ,  
 k ranges from 1.0 to 1.3

**NOTE**

The greater the k factor, the lower the DC bus level setting the ramp extension.

For example, when **C210**=0.2, power  $P_{out}$  shall exceed 5% of  $P_{max}$  in order to obtain  $k > 1$ .  
 When **C210**=2, 0.5% of  $P_{max}$  is required to obtain  $k > 1$ .

**NOTE**

Parameter **C210** is interlocked with parameter **P031** (Gradient variation acceleration reset) so that **C210 ≠ -0.01:With resistance** cannot be programmed in conjunction with **P031 = 0:No**.

**C211 Max. Time of Continuous Supply for Braking Resistance**

|             |                 |  |                |
|-------------|-----------------|--|----------------|
| <b>C211</b> | <b>Range</b>    | 0 ÷ 32000  | 0 ; 320.00 sec |
|             | <b>Default</b>  | 200  | 2.00 sec       |
|             | <b>Level</b>    | ENGINEERING  |                |
|             | <b>Address</b>  | 1211   |                |
|             | <b>Function</b> | This parameter determines the max. continuous operating time required for the braking resistance. If the braking resistance is used for a time <b>C211</b> without being activated, the braking resistance command is automatically disabled for a time of inactivity set in <b>C212</b> . |                |

**C212 Duty Cycle Braking (Ton/(Toff+Ton))**

|             |                 |   |          |
|-------------|-----------------|---|----------|
| <b>C212</b> | <b>Range</b>    | 0 ÷ 100   | 0 ÷ 100% |
|             | <b>Default</b>  | 10  | 10%      |
|             | <b>Level</b>    | ENGINEERING   |          |
|             | <b>Address</b>  | 1212  |          |
|             | <b>Function</b> | $C212 = (Ton / (Ton + Toff)) * 100$<br>This parameter determines the operating duty cycle allowed for the braking resistance. It is expressed as a percentage and defines the time of inactivity of the braking resistance when it is continuously operating for the max. time set in <b>C211</b> . |          |

**C213 Frequency Increase for Overvoltage Compensation – Smart Voltage Control**

|             |                 |   |            |
|-------------|-----------------|---|------------|
| <b>C213</b> | <b>Range</b>    | 0 ÷ 1000  | 0 ÷ 1000 % |
|             | <b>Default</b>  | 0   | 0 %        |
|             | <b>Level</b>    | ENGINEERING   |            |
|             | <b>Address</b>  | 1279  |            |
|             | <b>Control</b>  | IFD   |            |
|             | <b>Function</b> | If this parameter is set > 0, a value given by <b>C213</b> * derivative_voltage_DC (expressed in V/s) is summed up to the frequency currently set for the motor.<br>In that way, when DC voltage abruptly changes due to sudden variations of the load torque, the output frequency is promptly adjusted to compensate for voltage increase and avoid overvoltage conditions.<br>A value equal to 0.0200 ensures optimum operation in most applications; however, the optimum value for this parameter is to be found by trial and error. |            |



**NOTE** Parameter **C213** has no effect if **C210** = [With Resistance].

**C213a Torque Decrease Proportional Gain due to Overvoltage**

|              |                 |   |                |
|--------------|-----------------|---|----------------|
| <b>C213a</b> | <b>Range</b>    | 0 ÷ 32000   | 0.000 ÷ 32.000 |
|              | <b>Default</b>  | 20  | 0.020          |
|              | <b>Level</b>    | ENGINEERING   |                |
|              | <b>Address</b>  | 1251  |                |
|              | <b>Control</b>  | VTC   |                |
|              | <b>Function</b> | This function is available only when the VTC control is activated.<br>This is the proportional gain of the DC-bus voltage regulator adjusting the resisting torque limit when voltage exceeds the value set in parameter <b>C213c</b> . |                |

**C213b Torque Decrease Integral Gain due to Overvoltage**

|              |                 |   |                |
|--------------|-----------------|---|----------------|
| <b>C213b</b> | <b>Range</b>    | 0 ÷ 32000   | 0.000 ÷ 32.000 |
|              | <b>Default</b>  | 10  | 0.010          |
|              | <b>Level</b>    | ENGINEERING   |                |
|              | <b>Address</b>  | 1252  |                |
|              | <b>Control</b>  | VTC   |                |
|              | <b>Function</b> | This function is available only when the VTC control is activated.<br>This is the integral gain of the DC-bus voltage regulator adjusting the resisting torque limit when voltage exceeds the value set in parameter <b>C213c</b> . |                |

**C213c Voltage Reference for Torque Decrease**

|              |                 |  |              |
|--------------|-----------------|--|--------------|
| <b>C213c</b> | <b>Range</b>    | 0 ÷ 1200   | 0.0 ÷ 120.0% |
|              | <b>Default</b>  | 1000   | 100.0%       |
|              | <b>Level</b>    | ENGINEERING  |              |
|              | <b>Address</b>  | 1253   |              |
|              | <b>Control</b>  | VTC  |              |
|              | <b>Function</b> | This function is available only when the VTC control is activated.<br>It sets the reference value for the regulator DC voltage adjusting the resisting torque limit. The limiting function activates when voltage exceeds the value below:<br><b><math>V_{th} = C213c * V_{unlock} / 100</math></b><br>where <b>V<sub>unlock</sub></b> is based on the inverter voltage class and is typically higher than the trip voltage of the braking resistor. The default value ensures that the braking resistor trips before the torque limit function is activated. If the braking resistor is not fitted, it may be useful to set a lower value for this parameter to ensure prompt activation of the torque limit. |              |

**C213d Flux Limit due to Torque Decrease Activation**

|              |                 |  |              |
|--------------|-----------------|--|--------------|
| <b>C213d</b> | <b>Range</b>    | 0 ÷ 1000   | 0.0 ÷ 100.0% |
|              | <b>Default</b>  | 0  | 0.0%         |
|              | <b>Level</b>    | ENGINEERING  |              |
|              | <b>Address</b>  | 1254   |              |
|              | <b>Control</b>  | VTC  |              |
|              | <b>Function</b> | This function is available only when the VTC control is activated.<br>If the torque limit is adjusted by the DC bus voltage regulator, the rotor flux is decreased by the same value of the torque limit multiplied by the value of this parameter. Example: If the regulator generates a 50% instant torque limit and <b>C213d</b> is worth 30%, the flux will be decreased by $50 * 30 / (100 * 100) = 15\%$ , and will be increased to 85% of the value that should be adopted under normal operating conditions.<br>This parameter keeps DC voltage low when the motor acceleration due to external causes continues over time. Low parameter values (< 50%) may cause uncontrolled rotation of the motor. |              |

## 40. DC BRAKING MENU

### 40.1. Overview

When the IFD or VTC control algorithm are used, DC current can be injected into the motor to stop it. DC current may be automatically injected at stop and/or at start; DC current injection may also be controlled by the terminal board. All relevant parameters are included in the DC BRAKING MENU. The intensity of the DC current injected is expressed as a percentage of the rated current of the active motor.

#### 40.1.1. DC BRAKING AT START AND NON-CONDENSING FUNCTION

To activate DC braking at start, set **C216** to [YES]. Braking occurs after sending a **START** command, with a speed reference other than zero, before the acceleration ramp. A **START** command may be one of the following: **RUN** command or **REV** command sent via terminal board; **START** command from keypad, etc., depending on the preset control mode. DC braking level and duration are set in the following parameters:

**C220** Expressed as a percentage of the rated current of the controlled motor.

**C218** Expressed in seconds.

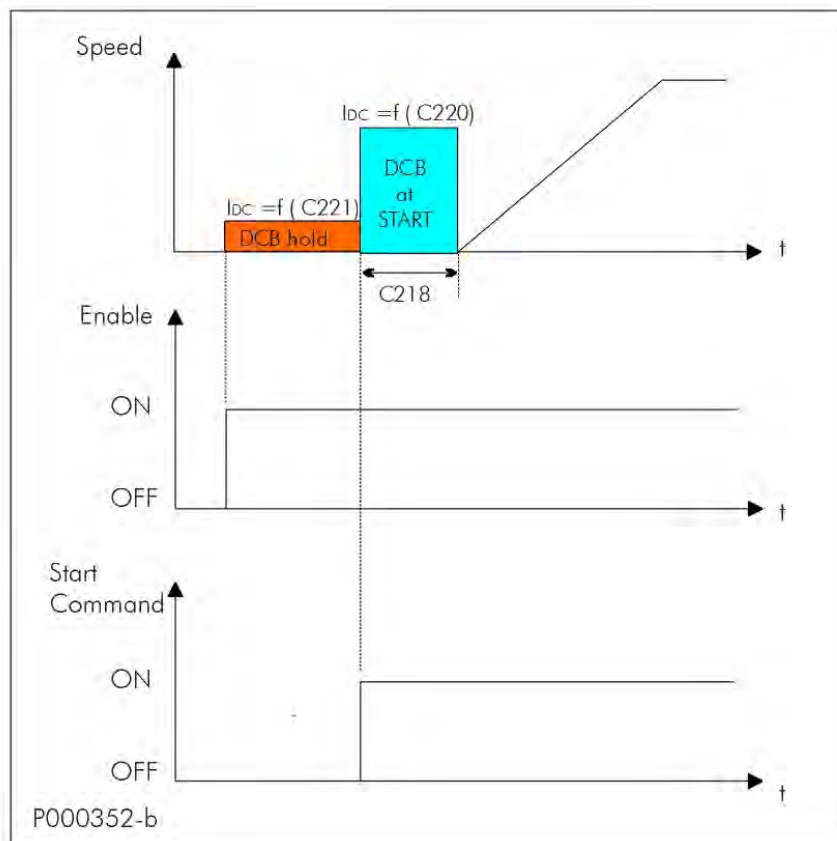

Figure 52: DCB Hold and DCB at Start

Output speed, holding and DC braking current when the DCB Hold and DCB at Start functions are active.

The non-condensing function consists in injecting DC into the motor. DC current brakes the motor and heats the motor windings, thus avoiding condensation. This function is active only for the IFD control if **C221** is other than zero and the **ENABLE** function is activated. For the other control algorithms, the non-condensing function is performed by injecting current during motor fluxing. Parameter **C221**, expressed as a percentage of the rated current of the controlled motor, determines the level of direct current injected into the motor.

Parameters used to program this function are the following:

- C216 enabling DCB at Start;**
- C218 setting the duration of DCB at Start;**
- C220 setting the intensity of the DC braking;**
- C221 setting the intensity of the holding current (this function is active for the IFD control only).**

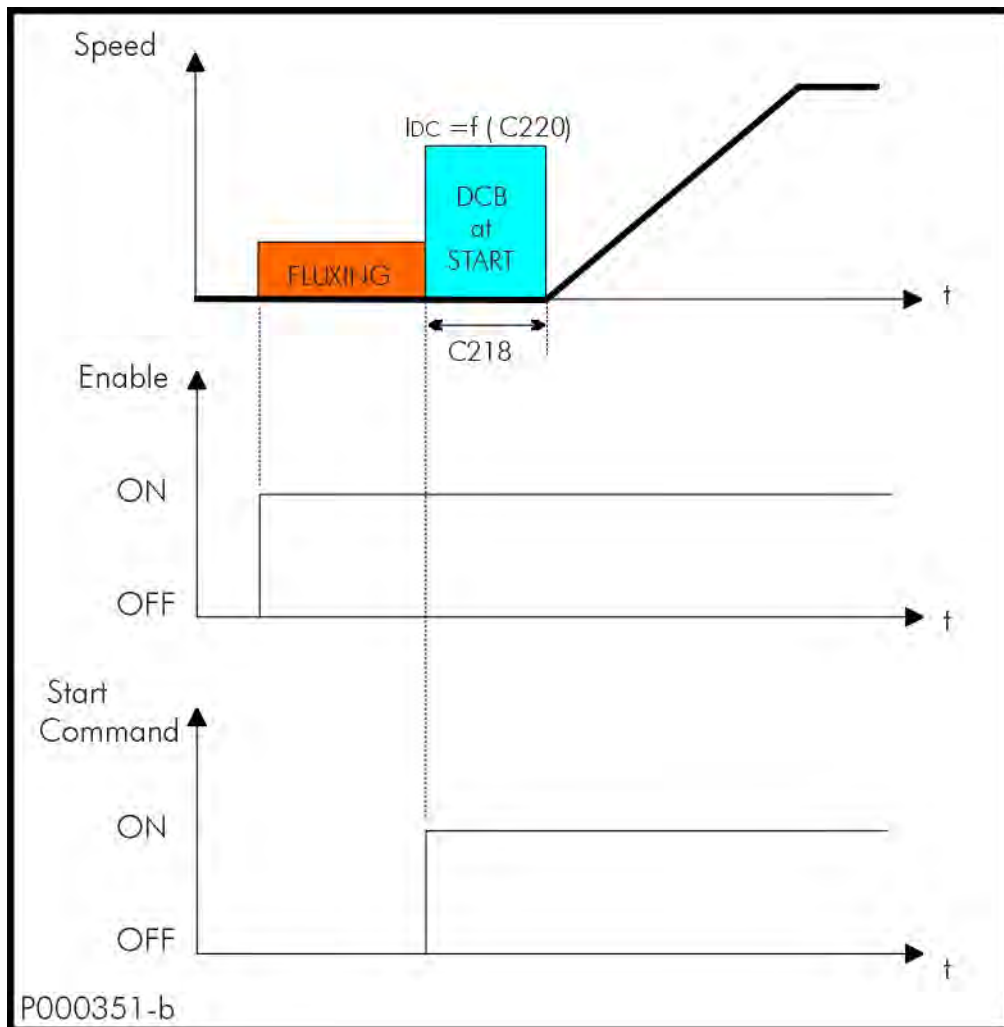

**Figure 53: DCB at Start with VTC Control**

Output Speed and DC Braking when the DCB At Start Function is active for the Vector Torque control.

### 40.1.2. DC BRAKING AT STOP

To activate this function, set **C215** to [YES] or, in Power Down mode, set **C234** (Power Down Stop Mode) as DCB. DC Braking occurs after sending a “stop with ramp” command. The speed level for DC Braking is set in **C219**. If the drive is in Power Down mode and **C234** is set as DCB, the speed level is set in **C235** (Power Down Stop Level). The figure below illustrates the output speed and DC Braking trends when the DC Braking at Stop function is active.

Parameters used to program this function are the following:

**C215** function enabling;

**C217** braking duration;

**C219** motor speed at the beginning of DC Braking;

**C220** intensity of DC braking.

In Power Down mode, if **C234** (Power Down Stop Mode) is set as DCB:

**C235** motor speed at the beginning of DC Braking.

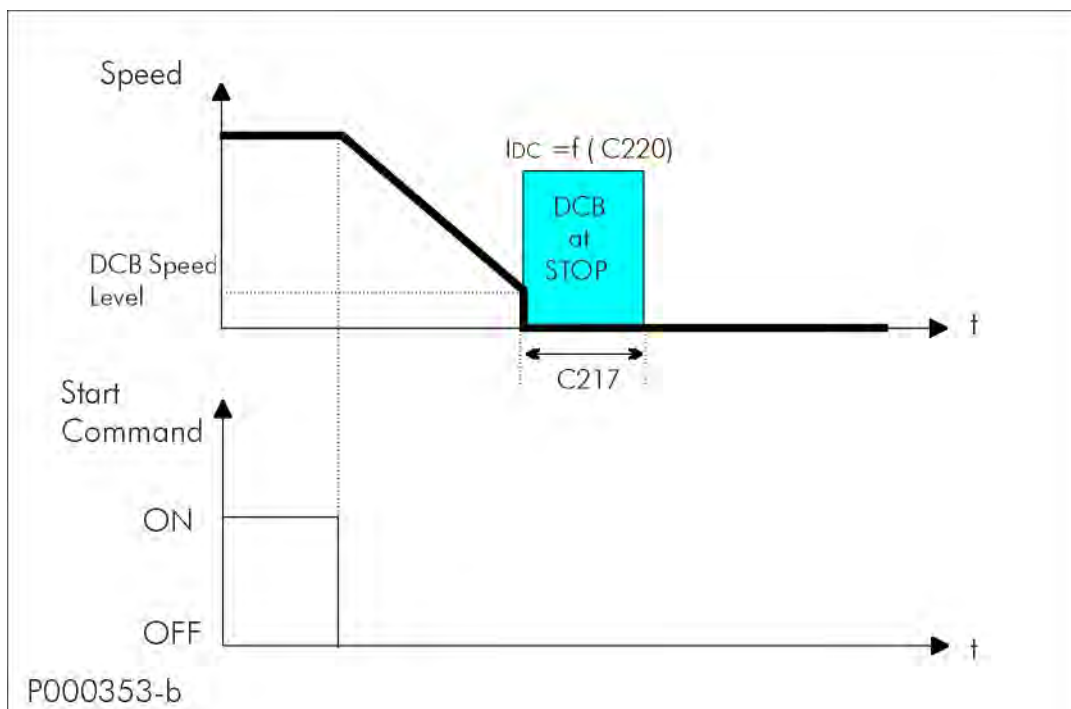

**Figure 54: DCB at Stop**

Motor speed and DC Braking patterns when the DC BRAKING AT STOP function is active.

### 40.1.3. DC BRAKING COMMAND SENT FROM TERMINAL BOARD

Activate the digital input set as DCB (C160) to send a DC Braking command. DC Braking duration is determined by the following formula:

$$t^* = C217 * (n_{OUT} / C219) \text{ with } n_{OUT} / C219 \text{ equal to max. } 10.$$

Possible cases:

- a)  $t1 > t^*$  time t1 for braking command is longer than t\*.

To restart the motor following the preset acceleration ramp when DC Braking is over, just disable the DCB command and disable and enable again the **START** command (see figure below).

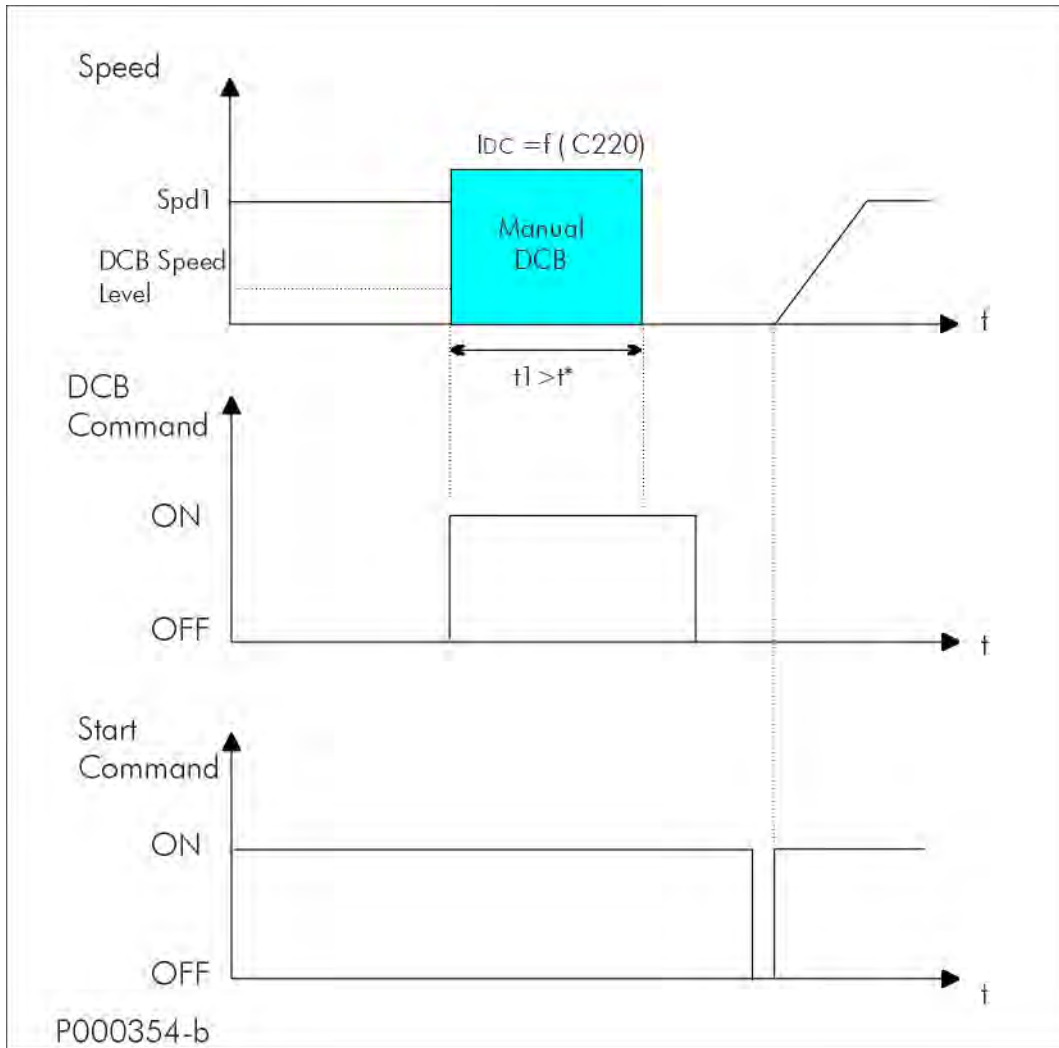

**Figure 55: Manual DCB (Example 1)**

Motor Speed, DC Braking, Manual DCB Command and START Command if  $t1 > t^*$ .

- b)  $t1 < t^*$  time t1 for braking command is shorter than t\*.  
Two different cases may occur, depending on the control algorithm and the setup of the motor speed searching function.

**IFD or VTC Control when the Speed Searching function is disabled (C245 [NO]):**

Prematurely disable the manual braking command to stop DC braking. If the motor is still rotating, it will start idling. To restart the motor following the preset acceleration ramp, simply disable and enable the **START** command (see Figure 56).

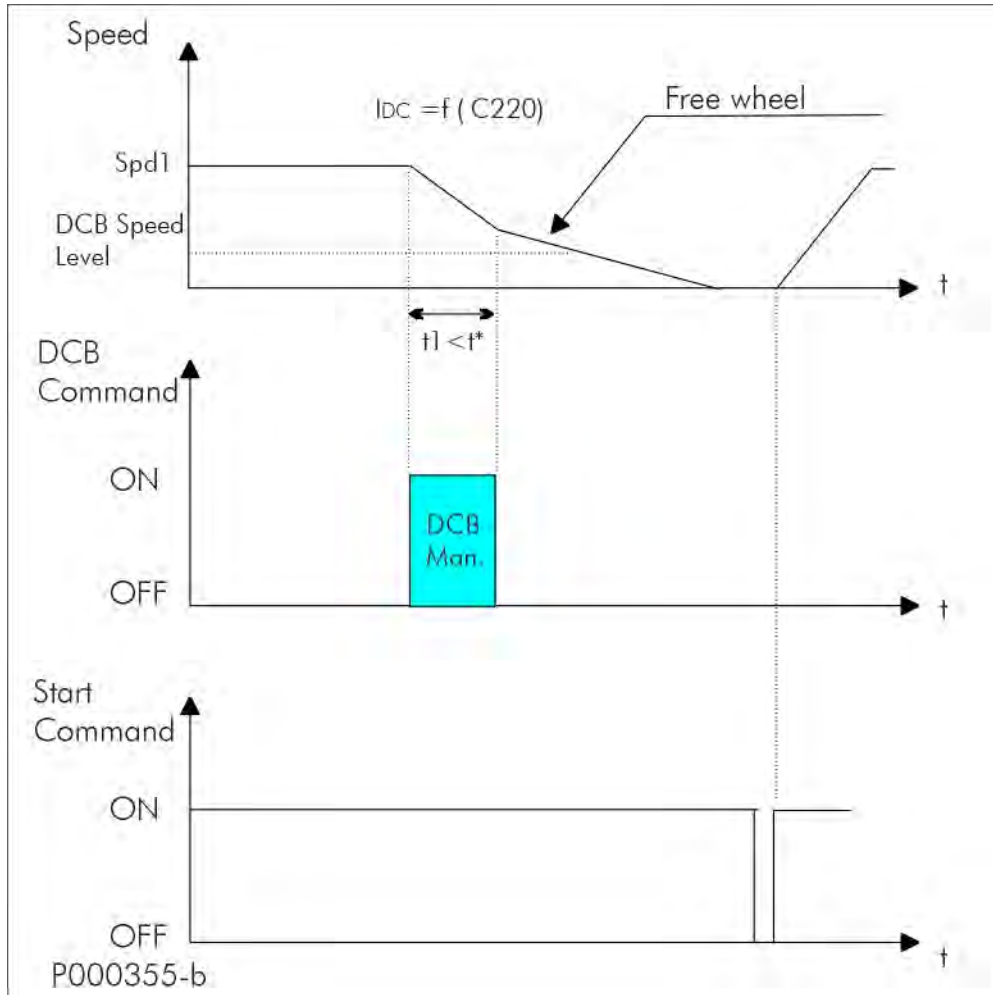
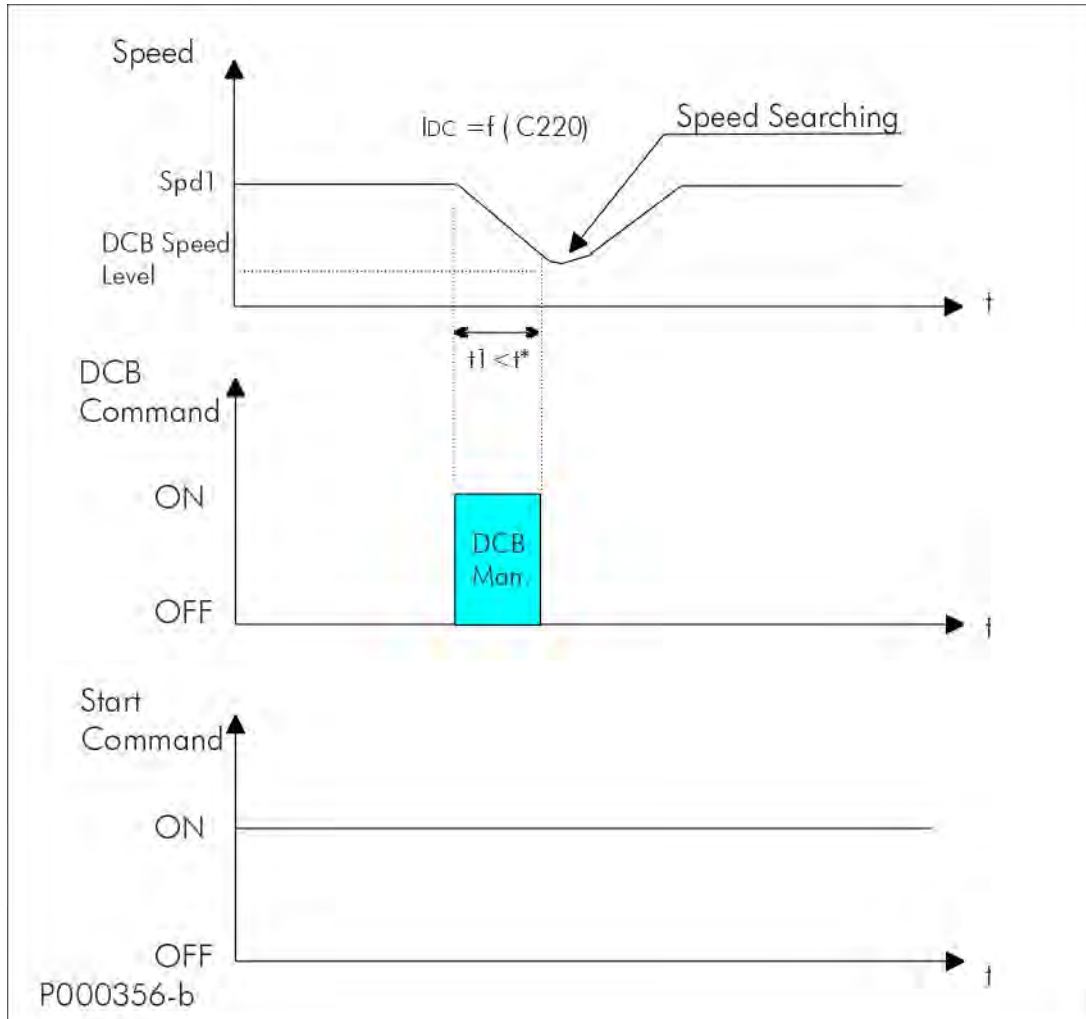

**Figure 56: Manual DCB (Example 2)**

Motor Speed, DC Braking, Manual DCB Command and START Command if  $t1 < t^*$  and the control algorithm is either IFD Voltage/Frequency or VTC VectorTorque when the Speed Searching Function is disabled.

**IFD Control when the Speed Searching function is enabled (C245 [YES]):**

Prematurely disable the manual braking command to activate the Speed Searching function. When the motor speed searching occurs, the motor speed is increased depending on the preset acceleration ramp (see Figure 57).



**Figure 57: Manual DCB (Example 3)**

Motor Speed, DC Braking and Manual DCB Command and START Command if  $t1 < t^*$ , the control algorithm is IFD and the Speed Searching Function is enabled.

## 40.2. List of Parameters C215 to C224

Table 107: List of parameters C215 to C224

| Parameter    | FUNCTION  | User Level  | MODBUS Address | Default Values            |
|--------------|---|-------------|----------------|---------------------------|
| <b>C215</b>  | Enabling DCB at Stop Function                       | ADVANCED    | 1215           | 0:NO                      |
| <b>C216</b>  | Enabling DCB at Start Function                      | ADVANCED    | 1216           | 0:NO                      |
| <b>C217</b>  | DCB at Stop Duration                                | ADVANCED    | 1217           | 0.5                       |
| <b>C218</b>  | DCB at Start Duration                               | ADVANCED    | 1218           | 0.5                       |
| <b>C219</b>  | Speed at the Beginning of DCB at Stop               | ADVANCED    | 1219           | 50rpm                     |
| <b>C219a</b> | VTC Speed Ramp Duration                             | ENGINEERING | 1213           | 500 ms                    |
| <b>C220</b>  | DCB Current Level                                   | ADVANCED    | 1220           | 100%                      |
| <b>C220a</b> | VTC Current Filter Time Constant                    | ENGINEERING | 1214           | 300 ms                    |
| <b>C220b</b> | Proportional Gain of the VTC Current Controller     | ENGINEERING | 1236           | 20                        |
| <b>C220c</b> | Integral Time Constant of the VTC Current Regulator | ENGINEERING | 1237           | 100 ms                    |
| <b>C221</b>  | DCB Hold  | ADVANCED    | 1221           | 0%                        |
| <b>C222</b>  | Ramp Braking Time for Motor 1 DCB                   | ENGINEERING | 1222           | See Table 80 and Table 84 |
| <b>C223</b>  | Ramp Braking Time for Motor 2 DCB                   | ENGINEERING | 1223           |                           |
| <b>C224</b>  | Ramp Braking Time for Motor 3 DCB                   | ENGINEERING | 1224           |                           |

### C215 Enabling DCB at Stop Function

| C215 | Range    | 0 ÷ 1   | 0: No; 1: Yes |
|------|----------|---|---------------|
|      | Default  | 0   | 0: No         |
|      | Level    | ADVANCED  |               |
|      | Address  | 1215  |               |
|      | Control  | IFD and VTC   |               |
|      | Function | Enables DC Braking during deceleration when the speed set in <b>C219</b> is reached (or the speed set in <b>C235</b> if in Power Down mode and <b>C234</b> [DCB] is reached). |               |

### C216 Enabling DCB at Start Function

| C216 | Range    | 0 ÷ 1                                     | 0: No; : Yes |
|------|----------|---|--------------|
|      | Default  | 0   | 0: No        |
|      | Level    | ADVANCED                                  |              |
|      | Address  | 1216                                      |              |
|      | Control  | IFD and VTC                               |              |
|      | Function | Enables the DC Braking at Start function. |              |

### C217 DCB at Stop Duration

| C217 | Range    | 1 ÷ 600  | 0.1; 60.0 sec. |
|------|----------|--|----------------|
|      | Default  | 5  | 0.5 sec        |
|      | Level    | ADVANCED   |                |
|      | Address  | 1217   |                |
|      | Control  | IFD and VTC  |                |
|      | Function | Determines the duration of the DCB at Stop function. |                |

**C218 DCB at Start Duration**

|             |                 |   |                 |
|-------------|-----------------|---|-----------------|
| <b>C218</b> | <b>Range</b>    | 1 ÷ 600   | 0.1 ÷ 60.0 sec. |
|             | <b>Default</b>  | 5   | 0.5 sec         |
|             | <b>Level</b>    | ADVANCED  |                 |
|             | <b>Address</b>  | 1218  |                 |
|             | <b>Control</b>  | IFD and VTC   |                 |
|             | <b>Function</b> | Determines the duration of the DCB at Start function. |                 |

**C219 Speed at the Beginning of DCB at Stop**

|             |                 |  |             |
|-------------|-----------------|--|-------------|
| <b>C219</b> | <b>Range</b>    | 0; 1000  | 0; 1000 rpm |
|             | <b>Default</b>  | 50   | 50rpm       |
|             | <b>Level</b>    | ADVANCED   |             |
|             | <b>Address</b>  | 1219   |             |
|             | <b>Control</b>  | IFD and VTC  |             |
|             | <b>Function</b> | Determines the speed at the beginning of DCB at stop while decelerating. |             |

**C219a VTC Speed Ramp Duration**

|              |                 |  |              |
|--------------|-----------------|--|--------------|
| <b>C219a</b> | <b>Range</b>    | 1 ÷ 32000  | 1 ÷ 32000 ms |
|              | <b>Default</b>  | 500  | 500 ms       |
|              | <b>Level</b>    | ENGINEERING  |              |
|              | <b>Address</b>  | 1213   |              |
|              | <b>Control</b>  | VTC  |              |
|              | <b>Function</b> | Ramp duration to zero speed before activating DC Brake in case of manual request by digital input (VTC control). |              |

**C220 DCB Current Level**

|             |                 |   |                                     |
|-------------|-----------------|---|-------------------------------------|
| <b>C220</b> | <b>Range</b>    | 0 ÷ MIN [ (Ipeak inverter/Imot)*100 ] ; 120]  | 0% ÷ Min[Ipeak inverter/Imot, 120%] |
|             | <b>Default</b>  | 100   | 100%                                |
|             | <b>Level</b>    | ADVANCED  |                                     |
|             | <b>Address</b>  | 1220  |                                     |
|             | <b>Control</b>  | IFD and VTC   |                                     |
|             | <b>Function</b> | Determines the level of direct current injected to brake the motor. It is expressed as a percentage of the rated current of the controlled motor. |                                     |

**C220a VTC Current Filter Time Constant**

|              |                 |  |              |
|--------------|-----------------|--|--------------|
| <b>C220a</b> | <b>Range</b>    | 0 ÷ 32000  | 0 ÷ 32000 ms |
|              | <b>Default</b>  | 300  | 300 ms       |
|              | <b>Level</b>    | ENGINEERING  |              |
|              | <b>Address</b>  | 1214   |              |
|              | <b>Control</b>  | VTC  |              |
|              | <b>Function</b> | Filter time constant for a smooth change between actual currents and DC Brake currents (id=i_DCB, iq=0) when the VTC control algorithm is activated. |              |

**C220b Proportional Gain of the VTC Current Controller**

|              |                 |  |           |
|--------------|-----------------|--|-----------|
| <b>C220b</b> | <b>Range</b>    | 0 ÷ 32000  | 0 ÷ 32000 |
|              | <b>Default</b>  | 20   | 20        |
|              | <b>Level</b>    | ENGINEERING  |           |
|              | <b>Address</b>  | 1236   |           |
|              | <b>Control</b>  | VTC  |           |
|              | <b>Function</b> | Current proportional gain during DC Braking when the VTC control algorithm is activated. |           |

**C220c Integral Time Constant of the VTC Current Regulator**

|              |                 |   |                         |
|--------------|-----------------|---|-------------------------|
| <b>C220c</b> | <b>Range</b>    | 1 ÷ 32000   | 1 ÷ 32000 ms [Disabled] |
|              | <b>Default</b>  | 100   | 100 ms                  |
|              | <b>Level</b>    | ENGINEERING   |                         |
|              | <b>Address</b>  | 1237  |                         |
|              | <b>Control</b>  | VTC   |                         |
|              | <b>Function</b> | Current integral time constant during DC Braking when the VTC control algorithm is activated. |                         |

**C221 DCB Hold**

|             |                 |   |         |
|-------------|-----------------|---|---------|
| <b>C221</b> | <b>Range</b>    | 0 ÷ 100   | 0; 100% |
|             | <b>Default</b>  | 0   | 0%      |
|             | <b>Level</b>    | ADVANCED  |         |
|             | <b>Address</b>  | 1221  |         |
|             | <b>Control</b>  | IFD   |         |
|             | <b>Function</b> | Determines the level of direct current injected during the Hold function. To activate this function, set a value other than zero in parameter <b>C221</b> . DC level is expressed as a percentage of the rated current of the controlled motor. |         |

**C222 (C223, C224) Ramp Braking Time for DCB**

|   |                 |  |                |
|---|-----------------|--|----------------|
| <b>C222 (Motor 1)<br/>C223 (Motor 2)<br/>C224 (Motor 3)</b> | <b>Range</b>    | 2 ÷ 32000  | 2 ÷ 32000 msec |
|   | <b>Default</b>  | See Table 80 and Table 84  |                |
|   | <b>Level</b>    | ENGINEERING  |                |
|   | <b>Address</b>  | 1222, 1223, 1224   |                |
|   | <b>Control</b>  | IFD and VTC  |                |
|   | <b>Function</b> | This parameter represents the time required for flux weakening before DCB. |                |

## 41. POWER DOWN MENU

### 41.1. Overview

In the case of power failure, the drive can be kept powered on by exploiting the kinetic energy of the motor and the load: energy recovered due to motor slowing down is used to power the drive, thus avoiding losing the drive control when a black-out occurs.

All parameters relating to the Power Down function are included in the Power Down submenu in the Configuration menu.

The following options are available (parameter **C225**):

- **[NO]**: The function is disabled.
- **[YES]**: After the time set in **C226** (Power Down start delay), starting from the instant when power down occurs, a deceleration ramp takes place (deceleration ramp in Power Down **C227**). The time period of the deceleration ramp can be user-defined.
- **[YES V]**: In case of power down for a time longer than **C226**, the motor coasts to stop, so that DC bus voltage value is kept constant at **C230**. To do so, a PI (proportional-integral) regulator is used, which is adjusted through parameter **C231** (proportional term) and **C232** (integral term).
- **[Alarm]**: In case of power down, when the time set in **C226** is over, alarm **A064** trips (factory setting).



**NOTE**

If the mains loss deactivates the **ENABLE-A** and **ENABLE-B** commands, the motor cannot coast to stop, because these commands are required for the hardware enable of IGBTs.



**NOTE**

If a drive is DC-powered by a Regenerative Penta (or an equivalent drive stabilizing DC bus voltage), Power Down cannot occur (**C008** = xT Regen, where x can be 2, 4, 5, or 6 ).

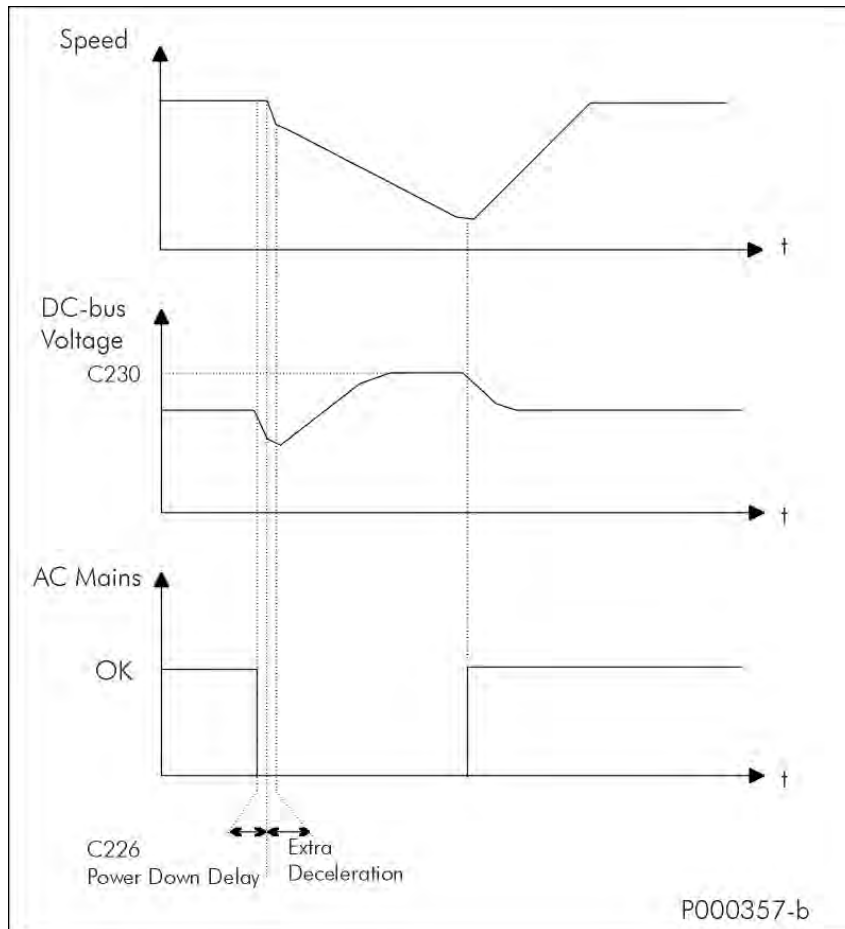

Figure 58: Power Down (Example)

The figure above illustrates the patterns of the motor speed and the DC bus voltage in case of mains loss. In the example above, power supply is restored before the drive turns off and before the deceleration ramp is over, so the motor accelerates with the preset acceleration ramp.

If power supply is restored during the deceleration ramp in Power Down, the connected motor accelerates following the selected acceleration ramp. A speed value for the end of Power Down can be set in **C235**; the desired operating mode at stop can be set in **C234**.

When the motor speed attains the end level of Power Down, the following functions can be selected in parameter **C234**:

– **[Stop]**: The drive will control the motor until it stops down, independently of the value set in **C235**.

When the motor stops and power supply is restored, the RUN command must be disabled and enabled again to accelerate the motor. Warning **W28 OPEN START** is displayed.

– **[DCB]**: When the speed of the Power Down end set in **C235** is attained, DC braking occurs.

If power supply is restored during DC braking, the RUN command must be disabled and enabled again to accelerate the motor. Warning **W28 OPEN START** is displayed.

– **[Stand-By]**: When the speed of the Power Down end set in **C235** is attained, the drive is in stand-by.

If power supply is restored when the drive is on stand-by, the RUN command must be disabled and enabled again to accelerate the motor. Warning **W28 OPEN START** is displayed.

## 41.2. List of Parameters C225 to C235

Table 108: List of parameters C225 to C235

| Parameter | FUNCTION  | Access Level | MODBUS Address | Default Values  |
|-----------|---|--------------|----------------|---|
| C225      | Procedure in case of Power Down                     | ENGINEERING  | 1225           | 3:Alarm   |
| C226      | Power Down enable delay                             | ENGINEERING  | 1226           | 10 ms   |
| C227      | Stop ramp time in Power Down                        | ENGINEERING  | 1227           | 20 sec  |
| C228      | Start increment of ramp gradient in P.D.            | ENGINEERING  | 1228           | 0.10%   |
| C229      | Improved sensitivity of DC bus control              | ENGINEERING  | 1229           | 1   |
| C230      | Voltage level of DC bus in Power Down               | ENGINEERING  | 1230           | 339V for class 2T<br>679V for class 4T(380;480V)<br>707V for class 4T(481;500V)<br>813V for class 5T<br>976V for class 6T |
| C231      | PI Proportional constant for automatic deceleration | ENGINEERING  | 1231           | 0.050   |
| C232      | PI Integral time for automatic deceleration         | ENGINEERING  | 1232           | 0.5 sec   |
| C234      | Ramp action at the end of Power Down                | ENGINEERING  | 1234           | 0: Stop   |
| C235      | Motor speed at the end of Power Down                | ENGINEERING  | 1235           | 0 rpm   |

### C225 Procedure in Case of Power Down

|             |                 |  |  |
|-------------|-----------------|--|--|
| <b>C225</b> | <b>Range</b>    | 0 ÷ 3  | 0: Disabled<br>1: Yes<br>2: YesV<br>3: Alarm |
|             | <b>Default</b>  | 3  | 3: Alarm                                     |
|             | <b>Level</b>    | ENGINEERING  |  |
|             | <b>Address</b>  | 1225   |  |
|             | <b>Function</b> | Type of power down:<br>0: <b>Disabled</b> The Power Down function is disabled.<br>1: <b>Yes</b> In case of mains loss after a time longer than the time set in <b>C226</b> starting from the mains loss detection, the deceleration ramp set in <b>C227</b> is performed.<br>2: <b>YesV</b> In case of mains loss, deceleration is automatically regulated by a PI regulator (see <b>C231</b> and <b>C232</b> ), so that voltage level in DC link is kept constant at the reference value set in <b>C230</b> .<br>IFD control: because no torque demand regulation is available, the deceleration ramp gradient is adjusted depending on the gradient value set in <b>C227</b> .<br>3: <b>Alarm</b> In case of power failure, the <b>A064 Mains Loss</b> alarm trips after the time set in <b>C226</b> . |  |



**NOTE**

If a drive is DC-powered by a Regenerative Penta (or an equivalent drive stabilizing DC bus voltage), Power Down cannot occur (**C008** = xT Regen, where x can be 2, 4, 5, or 6).

**C226 Power Down Enable Delay**

|             |                 |  |            |
|-------------|-----------------|--|------------|
| <b>C226</b> | <b>Range</b>    | 1 ÷ 250  | 1 ÷ 250 ms |
|             | <b>Default</b>  | 10   | 10 ms      |
|             | <b>Level</b>    | ENGINEERING  |            |
|             | <b>Address</b>  | 1226   |            |
|             | <b>Function</b> | This parameter determines the Power Down delay after a mains loss is detected by the drive.<br>If <b>C225</b> = Alarm, this delay is applied to the alarm tripped. |            |



**NOTE**

Setting a too long Power Down delay in case of mains loss can cause the drive to switch off.

**C227 Stop Ramp Time in Power Down**

|             |                 |   |               |
|-------------|-----------------|---|---------------|
| <b>C227</b> | <b>Range</b>    | 1 ÷ 32000   | 1 ÷ 32000 sec |
|             | <b>Default</b>  | 20  | 20 sec        |
|             | <b>Level</b>    | ENGINEERING   |               |
|             | <b>Address</b>  | 1227  |               |
|             | <b>Function</b> | Determines the gradient of the deceleration ramp occurring at Power Down (after the first extra deceleration stage) if <b>C225</b> = Yes.<br>IFD Control algorithm: <b>C227</b> is the basic gradient for deceleration adjustment when <b>C225</b> = Yes V. |               |

**C228 Start Increment of Ramp Gradient in Power Down**

|             |                 |  |                    |
|-------------|-----------------|--|--------------------|
| <b>C228</b> | <b>Range</b>    | -100 ÷ 10000   | -1.00 ÷ + 100.00 % |
|             | <b>Default</b>  | 10   | 0.10%              |
|             | <b>Level</b>    | ENGINEERING  |                    |
|             | <b>Address</b>  | 1228   |                    |
|             | <b>Function</b> | Determines an increase in deceleration ramp gradient at the beginning of the Power Down function. This is required to increase DC bus voltage.<br><b>C228 = 0%</b> start deceleration is due to C227 (C228 has no effect)<br><b>C228 = 100%</b> start deceleration is 100 times faster than deceleration set in C227 (start ramp = C227/100 sec)<br><b>C228 = -1.00%</b> start deceleration is zero (deceleration ramp of infinite time) |                    |

**C229 Improved Sensitivity of DC Bus Control**

|             |                 |   |         |
|-------------|-----------------|---|---------|
| <b>C229</b> | <b>Range</b>    | 1 ÷ 250   | 1 ÷ 250 |
|             | <b>Default</b>  | 1   | 1       |
|             | <b>Level</b>    | ENGINEERING   |         |
|             | <b>Address</b>  | 1229  |         |
|             | <b>Function</b> | Based on the DC bus voltage trend, this function allows detecting mains loss in advance.<br>If the value for this coefficient is too high, erroneous mains loss conditions can be detected, due to a sudden drop in DC bus voltage. |         |

**C230 Voltage Level of DC Bus in Power Down**

|             |                 |  |  |
|-------------|-----------------|--|--|
| <b>C230</b> | <b>Range</b>    | 250 ÷ 450 for Class 2T<br>400 ÷ 800 for Class 4T<br>500 ÷ 960 for Class 5T<br>600 ÷ 1150 for Class 6T                    | 250 ÷ 450 V for Class 2T<br>400 ÷ 800 V for Class 4T<br>500 ÷ 960 V for Class 5T<br>600 ÷ 1150 V for Class 6T                      |
|             | <b>Default</b>  | 339 for Class 2T<br>679 for Class 4T (380÷ 480V)<br>707 for Class 4T (481÷ 500V)<br>813 for Class 5T<br>976 for Class 6T | 339 V for Class 2T<br>679 V for Class 4T (380÷ 480V)<br>707 V for Class 4T (481÷ 500V)<br>813 V for Class 5T<br>976 V for Class 6T |
|             | <b>Level</b>    | ENGINEERING  |  |
|             | <b>Address</b>  | 1230   |  |
|             | <b>Function</b> | Determines the reference value for DC bus voltage in case of automatic deceleration in Power Down; <b>C225</b> = Yes V.  |  |

**C231 PI Proportional Constant for Automatic Deceleration**

|             |                 |   |                |
|-------------|-----------------|---|----------------|
| <b>C231</b> | <b>Range</b>    | 0 ÷ 32000   | 0.000 ÷ 32.000 |
|             | <b>Default</b>  | 50  | 0.050          |
|             | <b>Level</b>    | ENGINEERING   |                |
|             | <b>Address</b>  | 1231  |                |
|             | <b>Function</b> | Proportional coefficient used in PI regulator controlling automatic deceleration in case of Power Down; <b>C225</b> =Yes V. |                |

**C232 PI Integral Time for Automatic Deceleration**

|             |                 |  |  |
|-------------|-----------------|--|--|
| <b>C232</b> | <b>Range</b>    | 1 ÷ 32000  | 0.001 ÷ 31.999 sec<br>32000 = Disabled |
|             | <b>Default</b>  | 500  | 0.5 sec                                |
|             | <b>Level</b>    | ENGINEERING  |  |
|             | <b>Address</b>  | 1232   |  |
|             | <b>Function</b> | Integral time used in PI regulator controlling automatic deceleration in case of Power Down; <b>C225</b> =Yes V. |  |

**C234 Ramp Action at the End of Power Down**

|             |                 |   |                                  |
|-------------|-----------------|---|----------------------------------|
| <b>C234</b> | <b>Range</b>    | 0 ÷ 2   | 0: Stop<br>1: Stand-by<br>2: Dcb |
|             | <b>Default</b>  | 0   | 0: Stop                          |
|             | <b>Level</b>    | ENGINEERING   |                                  |
|             | <b>Address</b>  | 1234  |                                  |
|             | <b>Function</b> | <p>When the motor speed during Power Down attains the Power Down end value set in <b>C235</b>, three operating modes are possible depending on <b>C234</b> programming:</p> <p><b>[Stop]</b> If the drive is capable of bearing DC bus voltage, it will control the motor until it stops irrespective of the speed value set in <b>C235</b>. If power supply is restored when the deceleration ramp is over, the RUN command must be disabled and enabled again to accelerate the motor. If power supply is restored when the motor is still decelerating, the speed of reference is forced to the motor with the preset acceleration ramp.</p> <p><b>[Stand-by]</b> When decelerating, once the speed value set in <b>C235</b> is attained, the drive is put on stand-by and the motor keeps decelerating (motor idling). If power supply is restored, the same conditions as described in the step above (see [Stop]); instead of stopping the motor, the drive is put on stand-by.</p> <p><b>[DCB]</b> When decelerating, once the speed value set in <b>C235</b> is attained, DC braking occurs. Its duration depends on the speed value set in <b>C235</b> and on DC braking parameters (see the DC BRAKING MENU):<br/> <math>t^* = C217 * (C235 / C219)</math><br/>                     with <b>C235/C219</b> equal to max. 10. If power supply is restored, the same conditions as described in the step above occur (see [Stop]); instead of stopping the motor, the drive performs DC braking.</p> |                                  |

**C235 Motor Speed at the End of Power Down**

|             |                 |  |              |
|-------------|-----------------|--|--------------|
| <b>C235</b> | <b>Range</b>    | 0 ÷ 5000   | 0 ÷ 5000 rpm |
|             | <b>Default</b>  | 0  | 0 rpm        |
|             | <b>Level</b>    | ENGINEERING  |              |
|             | <b>Address</b>  | 1235   |              |
|             | <b>Function</b> | <p>Motor speed at the end of Power Down.<br/>                     If <b>C234</b> is set as [Stand-by], the drive is put on stand-by; if <b>C234</b> is set as [DCB], it determines DC braking. Both conditions occur during the deceleration ramp due to Power Down and when the speed value set in <b>C235</b> is attained.</p> |              |

## 42. SPEED SEARCHING MENU

### 42.1. Overview

---

When a command is sent to disable the drive, the motor idles. When the drive activates again, the Speed Searching function allows the drive to reach the motor speed.

All parameters relating to this function are included in the Speed Searching submenu in the Configuration menu.

For FOC control, the motor speed of rotation is always known, so this function is always active and independent of the parameters of the relevant menu.



**NOTE** The Speed Searching parameters are used for IFD and VTC control algorithm.

When **C245** is set to [YES], do the following to activate the Speed Searching function:

- deactivate and reactivate the **ENABLE** function before  $t_{SSdis}$  is over (**C246**);
- if **C185** = 1:[Free wheel], open and close the START command before  $t_{SSdis}$  (**C246**) is over;
- disable the DC Braking command before the DC braking preset time is over (see the DC BRAKING MENU);
- reset any alarm tripped (with reference other than 0) before  $t_{SSdis}$  is over.

If **C250**  $\neq$  0 [**Disable**], the Speed Searching function activates only if the programmed input is active.

Speed searching does not take place when the drive turns off due to mains loss.

If the drive restarts after a time longer than  $t_{SSdis}$  (**C246**), frequency output is generated following the acceleration ramp, and no speed searching takes place.

If **C246** 0: (**Always On**), speed searching (if enabled with **C245**) occurs when the drive restarts (RUN), irrespective of the time elapsed from disabling.

The figures below show output frequency and motor rpm during speed searching.

After time  $t_0$  for rotor demagnetization, speed searching occurs as follows (see 3 steps below):

**Speed at the beginning of the speed searching function depends on the settings in C249.**

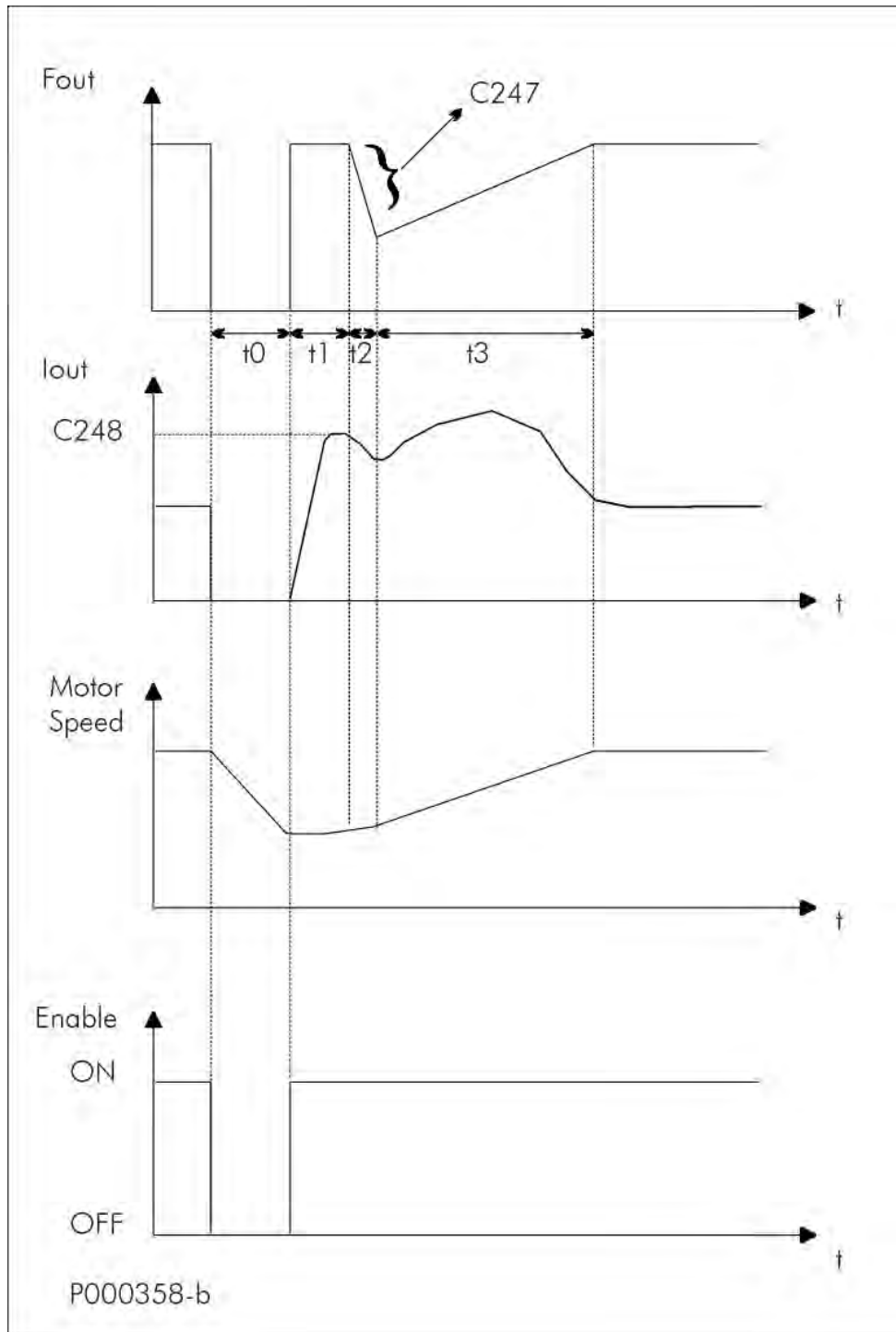

**Figure 59: Speed Searching (Example 1)**

– Output Frequency and motor RPM for the Speed Searching Function (**C245** = [YES]) activated by the **ENABLE-A** and **ENABLE-B** command.  $t_0 < t_{SSdis}$  (**C246**) or **C246** = 0.

Three stages:

- Time t<sub>1</sub>** The drive output frequency corresponds to the last value which was active before disabling the drive; output current matches with the value set in **C248**;
- Time t<sub>2</sub>** Output frequency is decremented following the ramp set in **C247** for rotation speed searching;
- Time t<sub>3</sub>** The connected motor accelerates following the acceleration ramp.

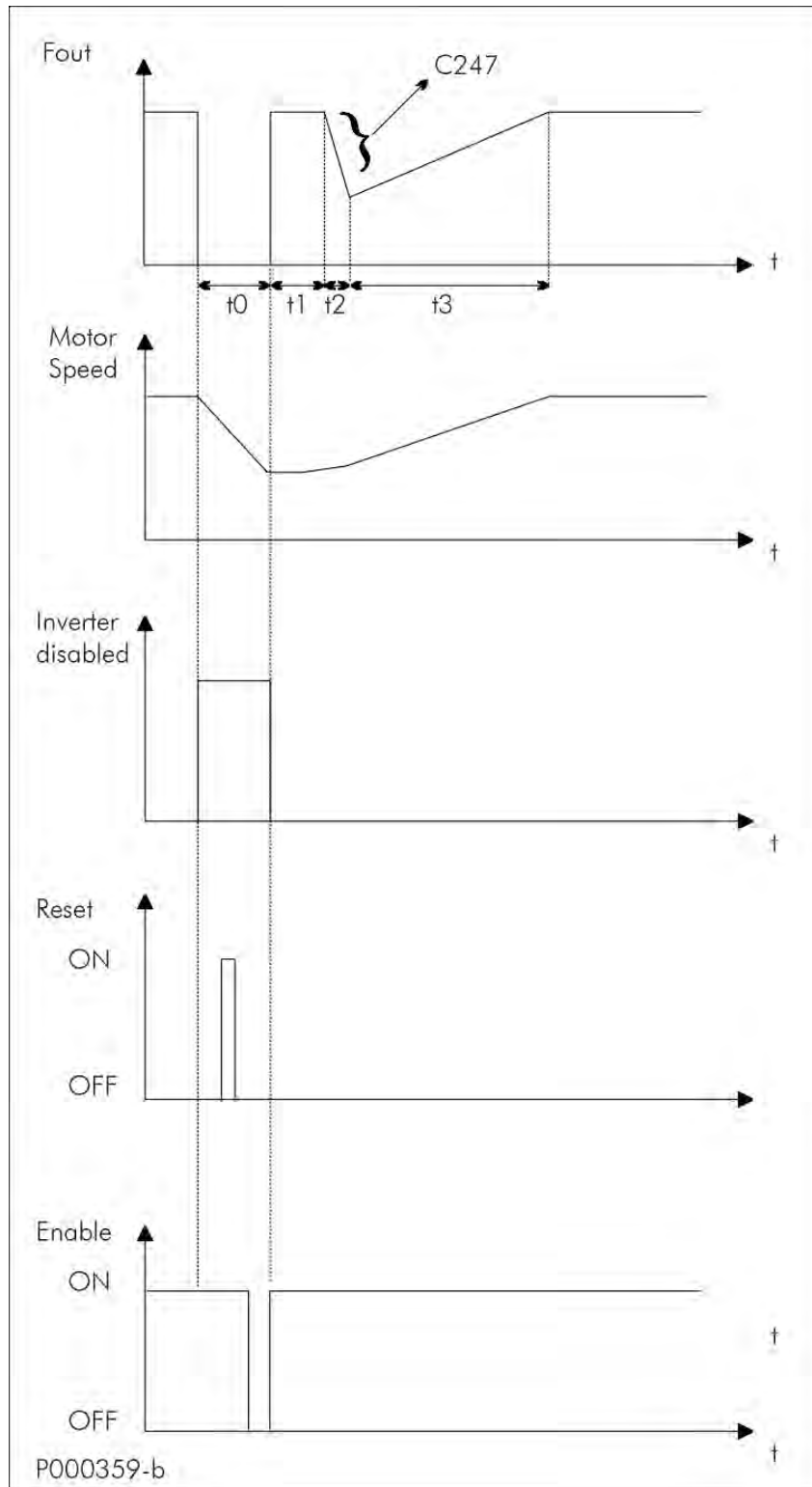

Figure 60: Speed Searching (Example 2)

Frequency, Motor Rpm, Drive Lock, **RESET** and **ENABLE** during Speed Searching (C245 = [YES]) due to an Alarm Trip  $t_{OFF} < t_{SSdis}$  (C246) or C246 = 0.



**NOTE**

If the Safety at Start function is disabled (C181 = [Inactive]), it is not necessary to activate and deactivate the **ENABLE** function; the Speed Searching activation would match with the **RESET** command.

## 42.2. List of Parameters C245 to C250

Table 109: List of parameters C245 to C250

| Parameter | FUNCTION                                    | User Level  | MODBUS Address | Default Values |
|-----------|---|-------------|----------------|----------------|
| C245      | Speed Searching enable                      | ENGINEERING | 1245           | 1: YES         |
| C246      | Run limit delay for Speed Searching         | ENGINEERING | 1246           | 1sec           |
| C247      | Speed Searching time as % deceleration ramp | ENGINEERING | 1247           | 10%            |
| C248      | Current used for Speed Searching            | ENGINEERING | 1248           | 75%            |
| C249      | Speed searching starting level              | ENGINEERING | 1249           | Last speed     |
| C250      | MDI for Speed Searching enable              | ENGINEERING | 1250           | 0: Disable     |

### C245 Speed Searching Enable

| C245 | Range    | 0 ÷ 1   | 0: No ÷ 1: Yes |
|------|----------|---|----------------|
|      | Default  | 0   | 0: No          |
|      | Level    | ENGINEERING   |                |
|      | Address  | 1245  |                |
|      | Control  | IFD, VTC  |                |
|      | Function | This parameter enables the speed searching function.<br>The Speed Searching function is enabled in the following cases:<br>– when the <b>ENABLE</b> function is deactivated and reactivated before time $t_{SSdis}$ ( <b>C246</b> );<br>– when the DC Braking command is disabled before the preset time is over (see the DC BRAKING MENU);<br>– when an alarm is reset (with a reference other than 0) before time $t_{SSdis}$ . |                |

### C246 Run limit delay for Speed Searching

| C246 | Range    | 0; 3000  | 0:[Always ON] ÷ 3000 sec |
|------|----------|--|--------------------------|
|      | Default  | 1  | 1 sec                    |
|      | Level    | ENGINEERING  |                          |
|      | Address  | 1246   |                          |
|      | Control  | IFD, VTC   |                          |
|      | Function | Determines the maximum allowable time passing between the drive disable and enable command when the Speed Searching function is activated. When the drive is restarted, output frequency will depend on the preset acceleration ramp. When <b>C246</b> = 0: (Always ON) , speed searching will always occur, independently of the time passing between the drive disable and enable. |                          |

**C247 Frequency Decrease Rate**

|             |                 |  |           |
|-------------|-----------------|--|-----------|
| <b>C247</b> | <b>Range</b>    | 1 ÷ 1000   | 1 ÷ 1000% |
|             | <b>Default</b>  | 10   | 10%       |
|             | <b>Level</b>    | ENGINEERING  |           |
|             | <b>Address</b>  | 1247   |           |
|             | <b>Control</b>  | IFD, VTC   |           |
|             | <b>Function</b> | <p>This parameter sets the frequency decrease rate during the speed search stage. The frequency decrease rate (expressed in Hz/s) is given from the following formula:</p> $(f_{max} \times C247) / 10$ <p>This means that when <b>C247</b>=100%=1, the Penta drive takes 10s to go from the max. frequency to 0Hz. When <b>C247</b>=10%=0.1 (default value), the system takes 100s to go from the max. frequency to 0Hz.</p> <p>The maximum frequency of the connected motor is given from the following formula:</p> $f_{max} = (npoles \times C029) / (2 \times 60).$ |           |



**NOTE** The frequency decrease rate is not dependent on the preset ramp times.



**NOTE** When the Penta drive enters the current limitation mode, the time the system takes for speed searching can be longer than the preset time.

**C248 Current Used for Speed Searching**

|             |                 |  |  |
|-------------|-----------------|--|--|
| <b>C248</b> | <b>Range</b>    | 20 ÷ Min[ <i>I</i> <sub>peak inverter</sub> / <i>I</i> <sub>mot</sub> , 100]                                       | 20% ÷ Min[ <i>I</i> <sub>peak inverter</sub> / <i>I</i> <sub>mot</sub> , 100%] |
|             | <b>Default</b>  | 75   | 75%  |
|             | <b>Level</b>    | ENGINEERING  |  |
|             | <b>Address</b>  | 1248   |  |
|             | <b>Control</b>  | IFD, VTC   |  |
|             | <b>Function</b> | Determines the max. current level for speed searching; it is expressed as a percentage of the rated motor current. |  |

**C249 Speed Searching Starting Level**

|             |                 |  |   |
|-------------|-----------------|--|---|
| <b>C249</b> | <b>Range</b>    | 0 ÷ 3  | 0: Last speed<br>1: MaxSpd/Last dir.<br>2: MaxSpd/Pos. Dir.<br>3: MaxSpd/Neg.Dir. |
|             | <b>Default</b>  | 0  | 0: Last speed   |
|             | <b>Level</b>    | ENGINEERING  |   |
|             | <b>Address</b>  | 1249   |   |
|             | <b>Control</b>  | IFD, VTC   |   |
|             | <b>Function</b> | <p>Speed Searching starts according to the value set in <b>C249</b>:</p> <p><b>C249 = 0:[Last Speed Value]</b> – the last speed search value generated before disabling the system is used for speed searching.</p> <p><b>C249 = 1:[MaxSpd/LastDir.]</b> – the max. speed programmed for the motor in the last direction of rotation of the connected motor is produced.</p> <p><b>C249 = 2:[MaxSpd/Pos.Dir]</b> – the speed searching function will begin with the max. speed programmed for the motor in the positive direction of rotation independently of the last frequency value produced before disabling the drive.</p> <p><b>C249 = 3:[MaxSpd/Neg.Dir]</b> – as “2”, but the direction of rotation of the connected motor will always be negative.</p> |   |

**C250 MDI for Speed Searching Enable**

|             |                 |  |   |
|-------------|-----------------|--|---|
| <b>C250</b> | <b>Range</b>    | 0 ÷ 16<br>0 ÷ 24 if ES847 or ES870 is fitted   | 0 → Inactive<br>1 ÷ 8 → MDI1 ÷ MDI8<br>9 ÷ 12 → MPL1 ÷ MPL4<br>13 ÷ 16 → TFL1 ÷ TFL4<br>17 ÷ 24 → XMDI1 ÷ XMDI8 |
|             | <b>Default</b>  | 0  | 0: Inactive   |
|             | <b>Level</b>    | ENGINEERING  |   |
|             | <b>Address</b>  | 1250   |   |
|             | <b>Control</b>  | IFD, VTC   |   |
|             | <b>Function</b> | If set to Inactive, it will take no effect. Otherwise, Speed Searching activates only if the preset input is active. |   |

## 43. AUTORESET MENU

### 43.1. Overview

The Autoreset function can be enabled in case an alarm trips. You can enter the maximum number of autoreset attempts and the time required for resetting the attempt number. If the Autoreset function is disabled, you can program an autoreset procedure at power on, which resets an active alarm when the drive is shut off. Undervoltage alarms or mains loss alarms can be saved in the fault list in the Autoreset menu.

To activate the Autoreset function, set a number of attempts other than zero in parameter **C255**. When the number of reset attempts is the same as the value set in **C255**, the autoreset function is disabled. It will be enabled again only when a time equal to or longer than the time set in **C256** has passed.

If the drive is turned off when an alarm is active, the alarm tripped is stored to memory and will be active at next power on. Regardless of the Autoreset function setup, an automatic reset of the last alarm stored can be obtained when the drive is next turned on (**C257** [Yes]). Undervoltage alarm **A047** (DC bus voltage below allowable threshold with motor running) or Mains Loss alarm **A064** (mains loss when the motor is running and the Power Down function is disabled) are not stored in the fault list when the drive is powered off (factory-setting). To enable parameter storage, set **C258** to [Yes].

### 43.2. List of Parameters C255 to C258

Table 110: List of parameters C255 to C258

| Parameter   | FUNCTION                                  | User Level  | MODBUS Address | Default Values |
|-------------|---|-------------|----------------|----------------|
| <b>C255</b> | Autoreset attempt number                  | ENGINEERING | 1255           | 0              |
| <b>C256</b> | Attempt counting reset time               | ENGINEERING | 1256           | 300 sec        |
| <b>C257</b> | Alarm reset at Power On                   | ENGINEERING | 1257           | 0: [Disabled]  |
| <b>C258</b> | Enable Undervoltage and Mains Loss alarms | ENGINEERING | 1258           | 0: [Disabled]  |

#### C255 Autoreset Attempt Number

| C255 | Range    | 0 ÷ 100   | 0 ÷ 100 |
|------|----------|---|---------|
|      | Default  | 0   | 0       |
|      | Level    | ENGINEERING   |         |
|      | Address  | 1255  |         |
|      | Function | If set other than 0, this parameter enables the Autoreset function and sets the max. allowable number of reset attempts. The autoreset attempt count is reset when a time equal to the time set in <b>C256</b> passes starting from the last alarm tripped. |         |

#### C256 Attempt Counting Reset Time

| C256 | Range    | 0; 1000  | 0; 1000 sec. |
|------|----------|--|--------------|
|      | Default  | 300  | 300 sec.     |
|      | Level    | ENGINEERING  |              |
|      | Address  | 1256   |              |
|      | Function | Determines the time that passes from the last alarm tripped to reset the autoreset attempt number. |              |

**C257 Alarm Reset at Power On**

|             |                 |  |                         |
|-------------|-----------------|--|-------------------------|
| <b>C257</b> | <b>Range</b>    | 0; 1   | 0: [Disabled]; 1: [Yes] |
|             | <b>Default</b>  | 0  | 0: [Disabled]           |
|             | <b>Level</b>    | ENGINEERING  |                         |
|             | <b>Address</b>  | 1257   |                         |
|             | <b>Function</b> | At power on, this parameter enables the automatic reset of the alarms tripped when the drive is powered off. |                         |

**C258 Enable Saving Undervoltage and Mains Loss Alarms**

|             |                 |  |                         |
|-------------|-----------------|--|-------------------------|
| <b>C258</b> | <b>Range</b>    | 0; 1   | 0: [Disabled]; 1: [Yes] |
|             | <b>Default</b>  | 0  | 0: [Disabled]           |
|             | <b>Level</b>    | ENGINEERING  |                         |
|             | <b>Address</b>  | 1258   |                         |
|             | <b>Function</b> | This parameter saves Undervoltage and Mains Loss alarms to the fault list. |                         |

## 44. MOTOR THERMAL PROTECTION MENU

### 44.1. Overview

The Motor Thermal Protection function protects the motor against overloads. Some Sinus Penta models offer the possibility to set the heatsink temperature for the activation of cooling fans. All relevant parameters are included in the Motor Thermal Protection menu.



**NOTE**

Each connected motor has its own thermal model. If the drive is used to control only one motor and its control mode is selected through the selection of the different motors, the motor thermal protection is ensured by setting PTC protection for all motors.

For each programmable motor, thermal protection can be configured in 4 modes, which can be selected with parameter **C265** (or **C268** or **C271** for motor 2 and 3 respectively), depending on the cooling system being used (configuration modes 1, 2 and 3):

| Value  | Descr.          | IEC 34-6 Compliance | Description   |
|--------|-----------------|---------------------|---|
| 0: NO  | [NO]            | -                   | The Motor Thermal Protection function is disabled;  |
| 1: YES | [No Derated]    | IC410               | The Motor Thermal Protection function is active with trip current <b>It</b> independent of operating speed (No derating);   |
| 2: YES | [Forced Cooled] | IC411               | The Motor Thermal Protection function is active with trip current <b>It</b> depending on operating speed, with fan-cooled motor de-rating (Forced Cooling);   |
| 3: YES | [Self Cooled]   | IC416               | The Motor Thermal Protection function is active; trip current <b>It</b> depends on operating speed and de-rating is suitable for motors having a fan keyed to the shaft (Fan on Shaft) (factory setting). |

When **C265**=1, 2 and 3, the motor thermal model is considered. The heating of a motor is proportional to the square of the current flowing ( $I_o^2$ ). The Motor overheated alarm (**A075**) will trip after the time "t" computed based on the motor thermal model is over.

The alarm can be reset only after a given time depending on the thermal constant (**C267**) of the motor, thus allowing for the correct cooling of the motor.

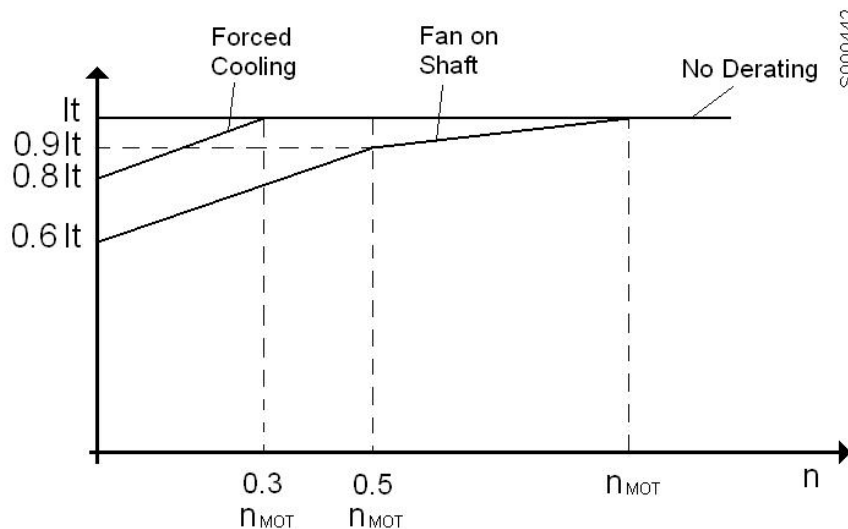

Figure 61: Trip current drop depending on speed values

The graph above shows how trip current **It** drops depending on the generated speed based on the value set in parameter **C265**.

**NOTE**

The motor heating can be monitored with measure **M026a**. This value is expressed as a percentage of the asymptotic value that can be attained.

When **C274**=Enabled, the thermal protection function is implemented from a PTC sensor: the PTC alarm (**A055**) trips when voltage acquired by AIN2 used as a PTC signal input exceeds a preset threshold value when the characteristic temperature is attained. Alarm A055 can be reset only if temperature decreases by 5% with respect to the trip temperature.

## 44.2. Choosing the Characteristic Parameters

---

Parameter **C266** relates to the instantaneous trip current that the internal thermal protection function will begin to monitor the current. The default value of 105% is a typical value and it is usually unnecessary to change it.

The motor thermal time is specific to the motor design and it varies between different motor manufacturers.

If the motor thermal time is unknown, the thermal time constant (**C267**) can be set up as described in the sections below (IEC Class, Maximum Locked Rotor Time – Basic and Maximum Locked Rotor Time – Enhanced). The first method is the most simple and gives an approximate result. The other two methods are more complex, but give more accurate results.

### 44.2.1. IEC CLASS

The motor can be protected as defined in the IEC 60947-4-1 standard for the thermal overload relays.

If the protection class is known, in order to set-up the thermal protection for a certain IEC trip class, the value of **C267** can be entered as:

| IEC Class | C267 [s] |
|-----------|----------|
| 10        | 360      |
| 20        | 720      |
| 30        | 1080     |

**Table 111: Suggested values for the motor thermal time constant**

The standard above defines a 7.2 ratio between LRC and FLC.

The value to be entered in **C267** is then defined from the formula below:

$$\mathbf{C267} = \text{IEC Class} \times 36.$$

If the ratio between LRC and FLC is not 7.2, please refer to the graph in Figure 62.

### 44.2.2. MAXIMUM LOCKED ROTOR TIME – BASIC

If the IEC class is not known, then the IEC class can be approximated by the procedure described below.

The following values must be known:

- Full Load Current (FLC) of the motor
- Locked Rotor Current (LRC)
- Maximum Locked Rotor Time (LRT) or Direct On Line (DOL) Start Time

The FLC of the motor can be obtained directly from the nameplate on the motor. The LRC and LRT must be obtained from the manufacturer or the motor datasheets.

The LRC, also referred to as starting current or motor start-up current, is the current that a motor draws at start-up when full voltage is applied to the terminals.

LRT is the time a motor can safely maintain LRC from a cold start. This information might also be available as a thermal withstand curve or a thermal damage curve. If this is the case, then the LRC and LRT must be deduced from the curves.

The following formula can be applied:

$$\text{IEC Class} = \frac{\text{LRC} \times \text{LRT}}{\text{FLC} \times 6}$$

Once the approximated IEC class has been calculated, use the motor thermal time constant (**C267**) that corresponds to the closest IEC class from above.

**Example 1a:** the 7.5kW motor in the table below can be approximated to have a trip class of:

$$\text{IEC Class} = \frac{820 \times 20}{100 \times 6} = 27.3$$

The motor thermal time constant that you would select is IEC class 30, **C267** = 1080s.



**NOTE**

As an even quicker guide, the IEC trip class can generally be approximated as the locked rotor time.

**Table 112: Typical datasheet for 4-pole, 50Hz-400V motors**

| Output [kW] | IEC Frame | Locked Rotor Current - LRC [% FLC] | Full Load Current - FLC [A] | Locked Rotor Time (cold) - LRT [s] | Rated speed [rpm] |               |
|-------------|-----------|------------------------------------|-----------------------------|------------------------------------|-------------------|---------------|
| 0.12        | 63        | 450                                | 0.41                        | 44                                 | 1415              |               |
| 0.18        | 63        | 460                                | 0.58                        | 59                                 | 1400              |               |
| 0.25        | 71        | 500                                | 0.7                         | 106                                | 1400              |               |
| 0.37        | 71        | 500                                | 1.03                        | 81                                 | 1395              |               |
| 0.55        | 80        | 600                                | 1.3                         | 37                                 | 1430              |               |
| 0.75        | 80        | 570                                | 1.61                        | 35                                 | 1420              |               |
| 1.1         | 90S       | 700                                | 2.37                        | 31                                 | 1445              |               |
| 1.5         | 90L       | 750                                | 3.28                        | 22                                 | 1450              |               |
| 2.2         | 112M      | 720                                | 4.42                        | 55                                 | 1455              |               |
| 4           | 112M      | 660                                | 7.85                        | 26                                 | 1445              |               |
| 5.5         | 132S/M    | 850                                | 10.34                       | 26                                 | 1465              |               |
| 7.5         | 132S/M    | 820                                | 14                          | 20                                 | 1465              | Example 1a/1b |
| 9.2         | 160M      | 560                                | 17.4                        | 59                                 | 1460              |               |
| 11          | 160M      | 600                                | 20.84                       | 42                                 | 1465              |               |
| 15          | 160L      | 650                                | 28.4                        | 37                                 | 1465              |               |
| 18.5        | 180M/L    | 800                                | 34.83                       | 26                                 | 1470              |               |
| 22          | 180L      | 790                                | 39.4                        | 35                                 | 1475              |               |
| 30          | 200L      | 700                                | 55.6                        | 40                                 | 1475              |               |
| 37          | 225S/M    | 720                                | 65.2                        | 35                                 | 1480              |               |
| 45          | 225S/M    | 740                                | 78.11                       | 33                                 | 1480              |               |
| 55          | 250S/M    | 720                                | 95.2                        | 37                                 | 1480              |               |
| 75          | 250S/M    | 750                                | 131.25                      | 35                                 | 1480              |               |
| 90          | 280S/M    | 780                                | 154.41                      | 55                                 | 1485              |               |
| 110         | 315S/M    | 760                                | 189                         | 64                                 | 1485              |               |
| 132         | 315S/M    | 780                                | 225.53                      | 55                                 | 1485              |               |
| 150         | 315S/M    | 750                                | 260                         | 44                                 | 1485              |               |
| 160         | 315S/M    | 760                                | 277                         | 44                                 | 1485              |               |
| 185         | 355M/L    | 720                                | 320                         | 117                                | 1490              |               |
| 200         | 355M/L    | 660                                | 342                         | 108                                | 1490              |               |
| 220         | 355M/L    | 700                                | 375                         | 84                                 | 1490              |               |
| 250         | 355M/L    | 690                                | 425                         | 79                                 | 1490              | Example 2     |
| 260         | 355M/L    | 650                                | 445                         | 90                                 | 1490              |               |
| 280         | 355M/L    | 710                                | 471                         | 86                                 | 1490              |               |
| 300         | 355M/L    | 670                                | 504                         | 103                                | 1490              |               |
| 315         | 355M/L    | 670                                | 529                         | 92                                 | 1490              |               |
| 330         | 355M/L    | 650                                | 554                         | 70                                 | 1490              |               |

### 44.2.3. MAXIMUM LOCKED ROTOR TIME – ENHANCED

If a more precise calculation is required, when the ratio between LRC and FLC is different from 7.2, you can refer to the graph below, where the x axis shows the LRC/FLC ratio, and the y axis shows the multiplicative constant to be applied to the LRT to calculate the value of parameter **C267**:

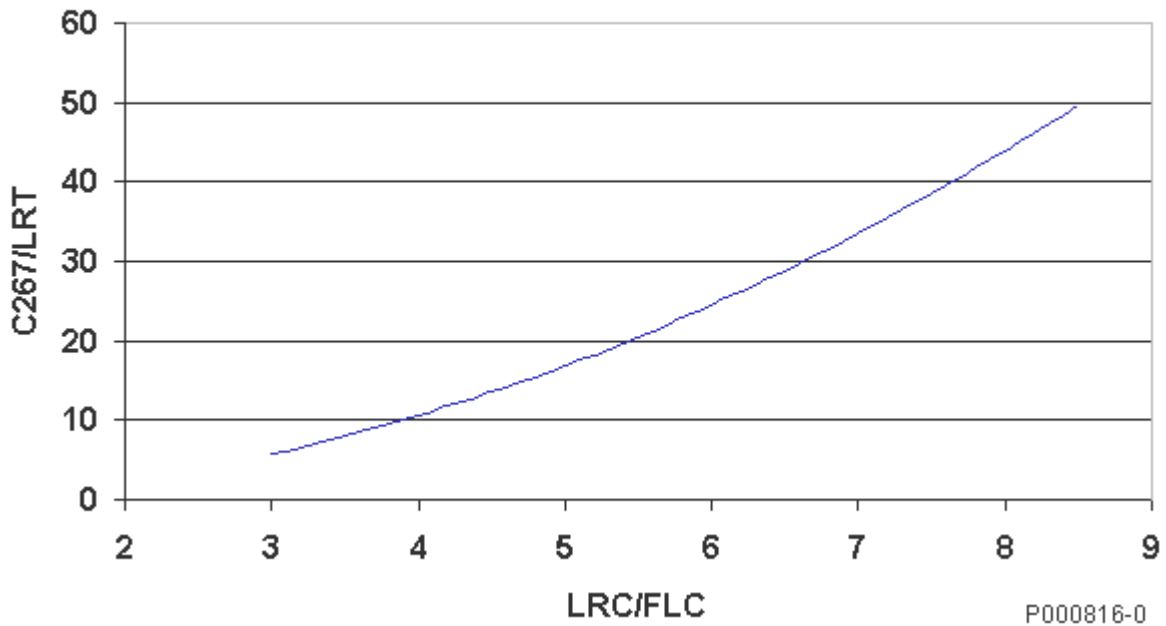

Figure 62: Set up of parameter C267 depending on the LRC/FLC ratio

**Example 1b:** When using a 7.5kW motor, the multiplicative constant corresponding to an LRC/FLC=8.2 is approx. 46 if referring to the graph above.

As a result, the motor thermal time constant that you would select is  $27.3 \times 46$ , **C267** = 1257s, which is a more accurate value than 1080s computed in Example 1a.

**Example 2:** The 250kW motor in Table 112 can be approximated to have a trip class of:

$$\text{IEC Class} = \frac{690 \times 79}{100 \times 6} = 90.85$$

Because this value is not given in Table 111, the motor thermal time constant that you would select is directly **C267** =  $90.85 \times 36 = 3260\text{s}$ , or  $90.85 \times 33 = 2998\text{s}$  if the value “33” is considered, resulting from Table 112 with a ratio between LRC/FLC=6.9.

### 44.3. Thermal Protection Trip Delay

The graph below shows the thermal protection trip delay depending on the IEC Class and the current flowing (which is supposed to be constant).

Parameter **C266** (trip current) is factory set to 105%.

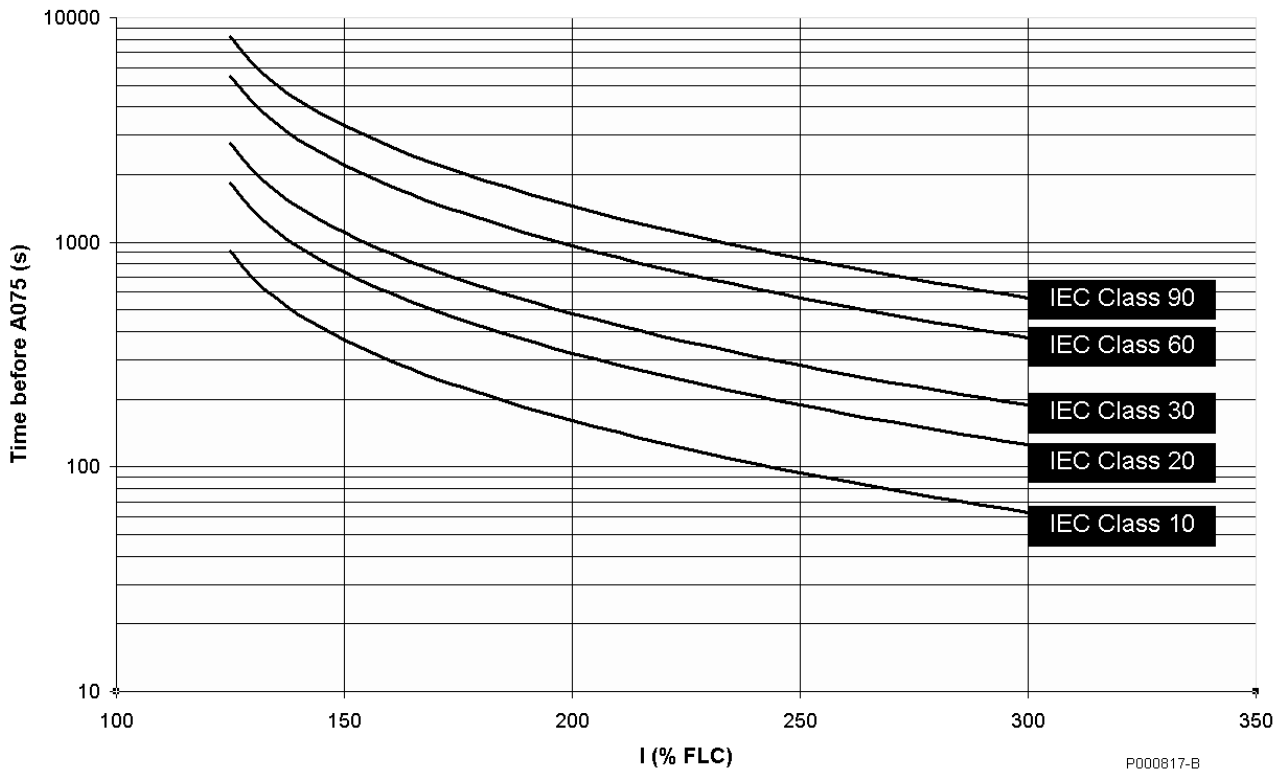

Figure 63: Trip delay of alarm A075 based on the IEC Class

Example: The protection level is compliant with IEC Class 30. If the current flowing is 200% of the FLC, alarm **A075** will trip after approx. 480s (8 minutes).

## 44.4. List of Parameters C264 to C274

Table 113: List of parameters C264 to C274

| Parameter    | FUNCTION                                  | User Level | MODBUS Address | Default Values |
|--------------|---|------------|----------------|----------------|
| <b>C264</b>  | Heatsink temperature for fan activation   | ADVANCED   | 1264           | 50°C           |
| <b>C264a</b> | Fan activation logic selector             | ADVANCED   | 1280           | 0: Default     |
| <b>C265</b>  | Thermal Protection activation for motor 1 | BASIC      | 1265           | 3: [Fan Shaft] |
| <b>C266</b>  | Trip current for motor 1 [Imot%]          | ADVANCED   | 1266           | 105%           |
| <b>C267</b>  | Thermal time constant for motor 1         | BASIC      | 1267           | 720s           |
| <b>C268</b>  | Thermal Protection activation for motor 2 | ADVANCED   | 1268           | 3: [Fan Shaft] |
| <b>C269</b>  | Trip current for motor 2 [Imot%]          | ADVANCED   | 1269           | 105%           |
| <b>C270</b>  | Thermal time constant for motor 2         | ADVANCED   | 1270           | 720s           |
| <b>C271</b>  | Thermal Protection activation for motor 3 | ADVANCED   | 1272           | 3: [Fan Shaft] |
| <b>C272</b>  | Trip current for motor 3 [Imot%]          | ADVANCED   | 1271           | 105%           |
| <b>C273</b>  | Thermal time constant for motor 3         | ADVANCED   | 1273           | 720s           |
| <b>C274</b>  | PTC Thermal Protection Enable             | BASIC      | 1274           | 0:[Disabled]   |

### C264 Heatsink Temperature for Fan Activation

|             |                 |  |          |
|-------------|-----------------|--|----------|
| <b>C264</b> | <b>Range</b>    | 0 ÷ 50   | 0 ÷ 50°C |
|             | <b>Default</b>  | 50   | 50°C     |
|             | <b>Level</b>    | ADVANCED   |          |
|             | <b>Address</b>  | 1264   |          |
|             | <b>Function</b> | This parameter sets the heatsink threshold for the activation of its cooling fans according to the control logic set in <b>C264a</b> .<br>This parameter is active only if <b>C264a</b> =0: Default or 2: By Temperature Only.<br>The real temperature of the heatsink can be displayed in measure parameter <b>M064</b> . |          |

### C264a Fan Activation Logic Selector

|              |                 |  |  |
|--------------|-----------------|--|--|
| <b>C264a</b> | <b>Range</b>    | 0 ÷ 2  | 0: [Default]<br>1: [Always On]<br>2: [By Temperature Only] |
|              | <b>Default</b>  | 0  | 0: [Default]   |
|              | <b>Level</b>    | ADVANCED   |  |
|              | <b>Address</b>  | 1280   |  |
|              | <b>Function</b> | This parameter defines the control logic of the heatsink cooling fans.<br>0: [Default]: The heatsink cooling fans are on whenever the drive is enabled (and IGBTs are switching); when the drive is disabled, fans are off only if the heatsink temperature drops below <b>C264</b> .<br>1: [Always On]: Fans are always on.<br>2: [By Temperature Only]: Fans are on only if the heatsink temperature is higher than the value set in <b>C264</b> , regardless of the drive status. |  |



**NOTE**

Parameters **C264** and **C264a** take effect only for the Penta models where fans are controlled directly by the drive control board (F), as displayed on the Product screen in the PRODUCT MENU . See Table 17 and Table 18.

|   |   |   |   |   |   |   |   |   |   |   |   |   |
|---|---|---|---|---|---|---|---|---|---|---|---|---|
| P | r | o | d | u | c | t | N | a | m | e |   |   |
| P | E | N | T | A |   |   |   |   |   |   |   |   |
| T | y | p | e | 0 | 0 | 2 | 0 | 4 | T | F | - | - |

**C265 (C268, C271) Thermal Protection Activation**

|   |                 |   |  |
|---|-----------------|---|--|
| <b>C265 (Motor 1)</b><br><b>C268 (Motor 2)</b><br><b>C271 (Motor 3)</b> | <b>Range</b>    | 0 ÷ 3   | 0 : [Disabled]<br>1 : [No Derating]<br>2 : [ForcedCool.]<br>3 : [Self-cool.] |
|   | <b>Default</b>  | 3   | 3: [Fan Shaft]   |
|   | <b>Level</b>    | BASIC (C265); ADVANCED (C268, C271)   |  |
|   | <b>Address</b>  | 1265; 1268; 1271  |  |
|   | <b>Function</b> | This parameter enables the Motor Thermal Protection function. It also selects the type of thermal protection among different trip patterns. |  |

**C266 (C269, C272) Trip Current**

|   |                 |   |                                       |
|---|-----------------|---|---------------------------------------|
| <b>C266 (Motor 1)</b><br><b>C269 (Motor 2)</b><br><b>C272 (Motor 3)</b> | <b>Range</b>    | 1 ÷ min [120%; (((Imax/Imot)*100) %)]   | 1 ÷ min [120%; (((Imax/Imot)*100) %)] |
|   | <b>Default</b>  | 105   | 105%                                  |
|   | <b>Level</b>    | ADVANCED  |                                       |
|   | <b>Address</b>  | 1266, 1269, 1272  |                                       |
|   | <b>Function</b> | This parameter sets the thermal protection trip current expressed as a percentage of the rated current of motor 1 (2, 3). |                                       |

**C267 (C270, C273) Thermal Time Constant**

|   |                 |   |                                      |
|---|-----------------|---|--------------------------------------|
| <b>C267 (Motor 1)</b><br><b>C270 (Motor 2)</b><br><b>C273 (Motor 3)</b> | <b>Range</b>    | 1 ÷ 10800   | 1 ÷ 10.800 s                         |
|   | <b>Default</b>  | 720   | 720s (corresponding to IEC Class 20) |
|   | <b>Level</b>    | BASIC (C267); ADVANCED (C270, C273)   |                                      |
|   | <b>Address</b>  | 1267; 1270; 1273  |                                      |
|   | <b>Function</b> | This parameter sets the thermal time constant of the connected motor. The time constant is the time within which the calculated thermal stage has reached 63% of its final value.<br>The motor attains its thermal time constant when it operates in constant load conditions for a time equal to approx. 5 times the constant set in this parameter. |                                      |

**C274 PTC Thermal Protection Enable**

|             |                 |  |                          |
|-------------|-----------------|--|--------------------------|
| <b>C274</b> | <b>Range</b>    | 0 ÷ 1  | 0: Disabled ÷ 1: Enabled |
|             | <b>Default</b>  | 0  | Disabled                 |
|             | <b>Level</b>    | ADVANCED   |                          |
|             | <b>Address</b>  | 1274   |                          |
|             | <b>Function</b> | This parameter enables the PTC probe (AIN2 analog input) |                          |



**NOTE**

If the PTC thermal protection (C274) is enabled, the reference from AIN2 is automatically managed as a 0 ÷10V input. The only parameter enabled for the control of AIN2 is P064; P060, P061, P062 and P063 cannot be viewed and are not considered for calculations.

## 45. MAINTENANCE MENU

### 45.1. Overview

The Maintenance menu allows setting partial counters for the drive Operation Time (OT) and Supply Time (ST). When the preset time is reached, a warning message appears (**W48** OT Time over and **W49** ST Time over respectively).

### 45.2. List of Parameters C275 to C278

Table 114: List of parameters C275 to C278

| Parameter | FUNCTION                     | User Level  | MODBUS Address | DEFAULT VALUES |
|-----------|------------------------------|-------------|----------------|----------------|
| C275      | Operation time counter reset | ENGINEERING | 1275           | NO             |
| C276      | Operation time threshold     | ENGINEERING | 1276           | 0h             |
| C277      | Supply time counter reset    | ENGINEERING | 1277           | NO             |
| C278      | Supply time threshold        | ENGINEERING | 1278           | 0h             |

#### C275 Operation time counter reset

|             |                 |   |                   |
|-------------|-----------------|---|-------------------|
| <b>C275</b> | <b>Range</b>    | 0 ÷ 1   | 0: [NO] ÷ 1 [YES] |
|             | <b>Default</b>  | 0   | NO                |
|             | <b>Level</b>    | ENGINEERING   |                   |
|             | <b>Address</b>  | 1275  |                   |
|             | <b>Function</b> | This parameter resets the partial counter for the drive operation time. |                   |

#### C276 Operation Time Threshold

|             |                 |  |             |
|-------------|-----------------|--|-------------|
| <b>C276</b> | <b>Range</b>    | 0 ÷ 65000  | 0 ÷ 650000h |
|             | <b>Default</b>  | 0  | 0h          |
|             | <b>Level</b>    | ENGINEERING  |             |
|             | <b>Address</b>  | 1276   |             |
|             | <b>Function</b> | This parameter sets the threshold for the operation time of the drive. When this time is exceeded, Warning “ <b>W48 OT Over</b> ” appears. To reset the warning message, reset the partial counter or set the counter threshold to zero. |             |

#### C277 Supply Time Counter Reset

|             |                 |  |                   |
|-------------|-----------------|--|-------------------|
| <b>C277</b> | <b>Range</b>    | 0 ÷ 1  | 0: [NO] ÷ 1 [YES] |
|             | <b>Default</b>  | 0  | NO                |
|             | <b>Level</b>    | ENGINEERING  |                   |
|             | <b>Address</b>  | 1277   |                   |
|             | <b>Function</b> | This parameter resets the partial counter for the drive supply time. |                   |

#### C278 Supply Time Threshold

|             |                 |   |             |
|-------------|-----------------|---|-------------|
| <b>C278</b> | <b>Range</b>    | 0 ÷ 65000   | 0 ÷ 650000h |
|             | <b>Default</b>  | 0   | 0h          |
|             | <b>Level</b>    | ENGINEERING   |             |
|             | <b>Address</b>  | 1278  |             |
|             | <b>Function</b> | This parameter sets the threshold for the supply time of the drive. When this time is exceeded, Warning “ <b>W49 ST Over</b> ” appears. To reset the warning message, reset the partial counter or set the counter threshold to zero. |             |

## 46. PID CONFIGURATION MENU

### 46.1. Overview

The Sinus Penta is provided with two separate PID (Proportional, Integral, Derivative) regulators allowing performing regulation loops such as pressure control, delivery control, etc., with no need to connect external auxiliary devices.

The PID Configuration Menu defines configuration parameters for the two PID regulators.

The configuration parameters for the PID regulator can be modified only when the drive is in stand-by and they set the following variables: reference sources, feedback sources and type of PID output action.

The programming parameters for the two PID regulators, including coefficients of proportional, integral and derivative terms, output saturation, etc., are covered in the PID PARAMETERS MENU and the PID2 PARAMETERS MENU.

### 46.2. Operation and Structure of the PID Regulator

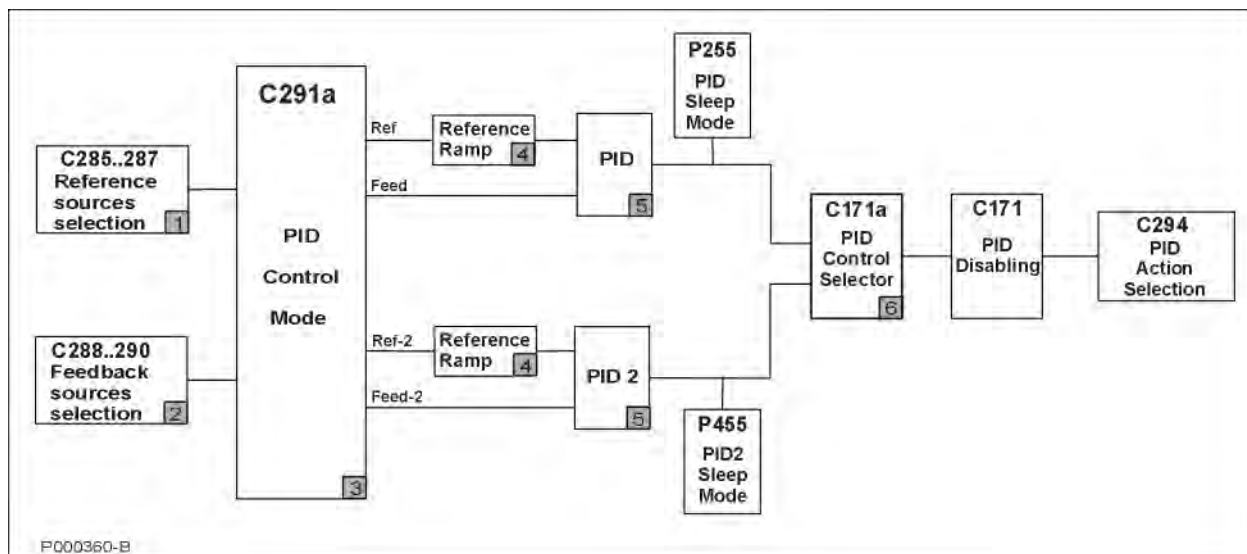

Figure 64: Structure of the PID Regulator

The figure above illustrates the block diagram of the PID regulator. Each block is described below:

#### Block 1: PID reference sources

Multiple reference sources can be selected at a time (up to 3 reference sources can be selected with parameters **C285**, **C286**, **C287**).

The resulting reference value depends on the setup in **C291a** (see block 3).

Dynamic selection is possible between two reference sources using the digital input configured as the source selector (see **C179**); this parameter has effect only if the Two PIDs mode is activated.

#### Block 2: PID feedback sources

Multiple feedback sources can be selected at a time (up to 3 feedback sources can be selected with parameters **C288**, **C289**, **C290**).

The resulting reference value depends on the setup in **C291a** (see block 3).

Dynamic selection is possible between two feedback sources using the digital input configured as the source selector (see **C179**); this parameter has effect only if the Two PIDs mode is activated.



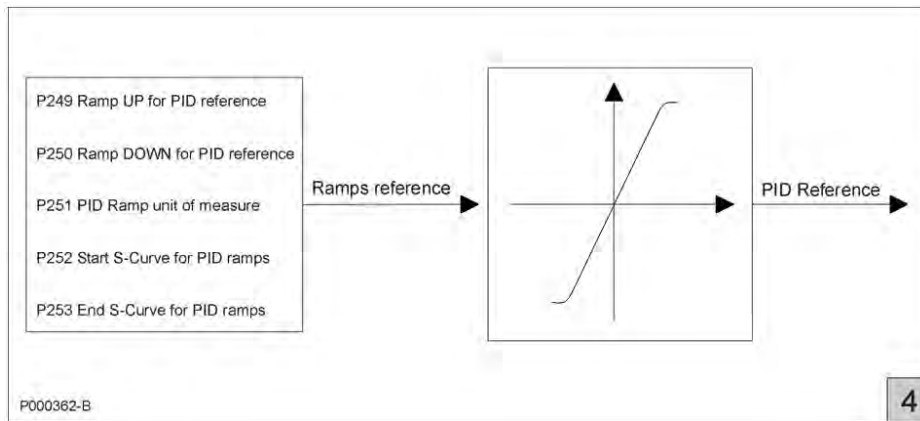

Figure 66: PID ramp reference



**NOTE** The PID2 ramp reference control is the same, but parameters **P2xx** are replaced with parameters **P4xx**.

**Block 5: PID regulators**

This is the real PID regulator. Its output may be disabled by an external digital command (if programmed with **C171**). If the PID regulator is used as a reference source and **P255** (**P455** for PID2) is not set to zero, the PID output value control is enabled. If the PID output equals the preset minimum value for a time longer than **P255** (**P455** for PID2), the drive is automatically put on stand-by.

In the last block, the PID output is applied to the function defined by the “PID Action” parameter (**C294**).

The PID regulator structure is detailed in the diagram below (block 5).

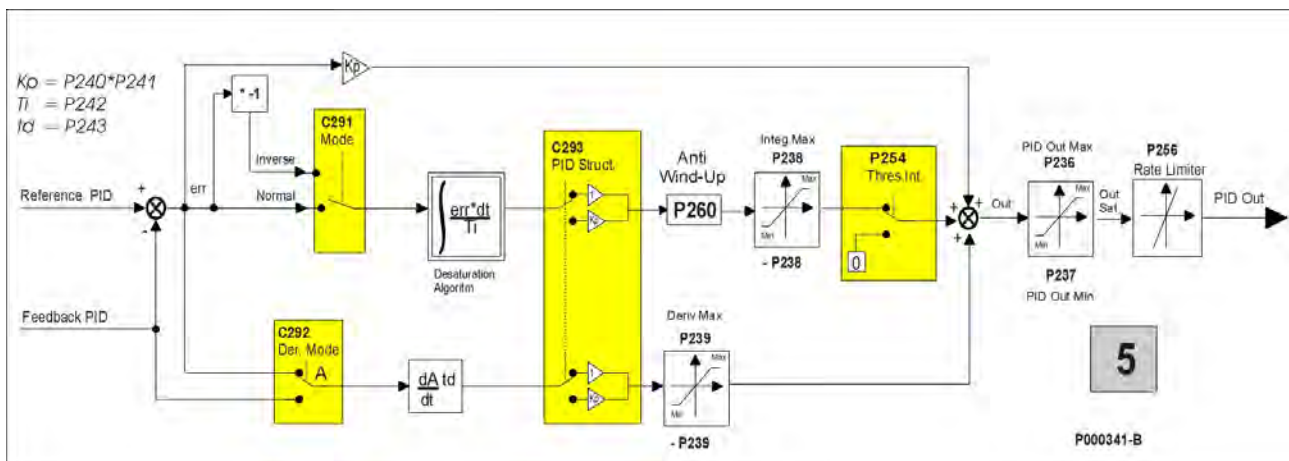

Figure 67: Details of the PID regulator structure



**NOTE** The PID2 structure is the same as the PID structure, but parameters **P2xx** are replaced with **P4xx** and parameter **C291** is replaced with parameter **C291b**. Parameters **C292** and **C293** are in common for PID and PID2.

**Block 6: Digital input for PID control selection.**

Block 6 activates only when both PIDs are enabled (**C291a** = 2 PID) or when in 2-Zone mode (**C291a** = 2-Zone MIN or 2-Zone MAX).

In Two PIDs mode:

if **C171a = 0: Disabled**, the PID output is summed with the PID2 output;

if **C171a** is enabled, the logic state of the configured input determines which is the output of the PID regulator to be used: 0 → PID, 1→ PID2.

In 2-zone mode:

if **C171a** is enabled, when the selected input is activated, the 2-zone mode (MIN or MAX) is disabled. In that case, the PID regulator always operates on the error resulting from **C285–C288** and with parameters **P2xx**.

The PID regulator output may be used as:

- an external output;
- a speed/torque reference of the drive;
- a speed/torque reference increase or, if the IFD control is used, the PID regulator input may be used for correcting the output voltage.

If the PID regulator output is the speed reference of the drive, the selected speed/torque ramp is applied.

**SERIAL LINK**

The **Serial Link** source is an input from the MODBUS link: the reference value shall be written by the user to the following addresses:

**Table 115: Reference sources from serial link**

| MODBUS Address | Input | User Level | Type of Reference | Description         | Unit of Measure    |
|----------------|-------|------------|-------------------|---------------------|--------------------|
| 1418           | I031  | BASIC      | PID Reference     | PID reference value | Set in <b>P267</b> |
| 1420           | I033  | BASIC      | PID Feedback      | PID feedback value  | Set in <b>P267</b> |

### 46.3. List of Parameters C285 to C294

**Table 116: List of parameters C285 to C294**

| Parameter    | FUNCTION  | User Level  | MODBUS Address | Default Values |
|--------------|---|-------------|----------------|----------------|
| <b>C285</b>  | Selection of PID reference n. 1                               | ENGINEERING | 1285           | 2:AIN1         |
| <b>C286</b>  | Selection of PID reference n. 2                               | ENGINEERING | 1286           | 0:Disable      |
| <b>C287</b>  | Selection of PID reference n. 3                               | ENGINEERING | 1287           | 0:Disable      |
| <b>C288</b>  | Selection of PID feedback n. 1                                | ENGINEERING | 1288           | 3:AIN2/PTC     |
| <b>C289</b>  | Selection of PID feedback n. 2                                | ENGINEERING | 1289           | 0:Disable      |
| <b>C290</b>  | Selection of PID feedback n. 3                                | ENGINEERING | 1290           | 0:Disable      |
| <b>C291</b>  | PID operating mode  | ENGINEERING | 1291           | 0:Disable      |
| <b>C291a</b> | PID control mode  | ENGINEERING | 1295           | 0:Standard SUM |
| <b>C291b</b> | PID2 operating mode   | ENGINEERING | 1296           | 1: Normal      |
| <b>C292</b>  | Selection of the variable for calculating the derivative term | ENGINEERING | 1292           | 0:Measure      |
| <b>C293</b>  | Proportional Multiplier of derivative and integral terms      | ENGINEERING | 1293           | 0:NO           |
| <b>C294</b>  | PID action  | ENGINEERING | 1294           | 1:Reference    |

**C285 (C286,C287) Selection of PID Reference n. 1 ( 2, 3)**

|                          |                 |   |  |
|--------------------------|-----------------|---|--|
| <b>C285 (C286, C287)</b> | <b>Range</b>    | 0 ÷ 10<br>0 ÷ 12 when ES847 is fitted   | 0: Disable<br>1: REF<br>2: AIN1<br>3: AIN2/PTC<br>4: Pulse Input<br>5: Serial Link<br>6: Fieldbus<br>7: Keypad<br>8: Encoder<br>9: V out<br>10: Up Down from MDI<br>11: XAIN4<br>12: XAIN5 |
|                          | <b>Default</b>  | <b>C285</b> = 2<br><b>C286</b> = 0<br><b>C287</b> = 0   | <b>C285</b> = 2: AIN1<br><b>C286</b> = 0<br><b>C287</b> = 0  |
|                          | <b>Level</b>    | ENGINEERING   |  |
|                          | <b>Address</b>  | 1285 (1286, 1287)   |  |
|                          | <b>Function</b> | <p><b>C285</b> selects the first PID reference source from the PID regulator. Up to three reference sources may be configured (<b>285 – C287</b>) considered as a sum. The sources are used by the PID and are expressed in percentage values (with reference to their max. value and min. value set in the References menu). If multiple reference sources are selected, their sum is considered. They are saturated between <b>P246</b> and <b>P245</b> (PID reference maximum and minimum value respectively).</p> <p>Source 9 (V out) is useful when <b>C294</b> = 3: Voltage Sum. This is the output voltage in IFD control with no PID corrections.</p> <p>Reference sources 11 and 12 can be selected only after setting <b>XAIN</b> in parameter <b>R023</b>.</p> |  |

**C288 (C289,C290) Selection of PID Feedback n.1 (2, 3)**

|                          |                 |   |   |
|--------------------------|-----------------|---|---|
| <b>C288 (C289, C290)</b> | <b>Range</b>    | 0 ÷ 14<br>0 ÷ 16 when ES847 is fitted   | 0: Disable<br>1: REF<br>2: AIN1<br>3: AIN2/PTC<br>4: Pulse Input<br>5: Serial Link<br>6: Fieldbus<br>7: Keypad<br>8: Encoder<br>9: Iout<br>10: Vout<br>11: Vdc<br>12: Pout<br>13: Vout measured<br>14: Tout<br>15: XAIN4<br>16: XAIN5 |
|                          | <b>Default</b>  | <b>C288</b> = 3<br><b>C289</b> = 0<br><b>C290</b> = 0   | <b>C288</b> = 3: AIN2/PTC<br><b>C289</b> = 0: Disable<br><b>C290</b> = 0: Disable   |
|                          | <b>Level</b>    | ENGINEERING   |   |
|                          | <b>Address</b>  | 1288 (1289, 1290)   |   |
|                          | <b>Function</b> | <p><b>C288</b> selects the first PID feedback source. Up to three feedback sources can be configured among the available reference sources. If multiple sources are selected, their sum is considered. They are saturated based on parameters <b>P247</b> and <b>P248</b> (PID feedback maximum and minimum value respectively). See also parameter <b>C285</b>.</p> <p>Feedback source 13 is useful if <b>C294</b> = 3: Add Voltage. This is a RMS measure of the output voltage obtained from the readout of the values of two properly transformed phase-to-phase output voltages from <b>AIN1</b> and <b>AIN2</b>.</p> <p>Feedback sources 15 and 16 can be selected only after setting <b>XAIN</b> in parameter <b>R023</b>.</p> |   |

**C291 PID Operating Mode**

|             |                 |  |                                       |
|-------------|-----------------|--|---------------------------------------|
| <b>C291</b> | <b>Range</b>    | 0 ÷ 2  | 0: Disable<br>1: Normal<br>2: Reverse |
|             | <b>Default</b>  | 0  | 0: Disable                            |
|             | <b>Level</b>    | ENGINEERING  |                                       |
|             | <b>Address</b>  | 1291   |                                       |
|             | <b>Function</b> | <p>This parameter defines how to compute the PID output. Three computing modes are available: 0: <b>Disable</b>, 1: <b>Normal</b>, 2: <b>Reverse</b>.</p> <p>If <b>0: Disable</b> is selected, the PID regulator is inactive and its output is always set to zero.</p> <p>In <b>Normal</b> mode, the real PID output is considered.</p> <p>If <b>2: Reverse</b> is selected, the output actuated by the PID regulator results from the subtraction of the max. output value set in <b>P236</b> from the output obtained by the PID regulator.</p> <p>This operating mode can be used for special applications (see the Keeping Fluid Level Constant (Example) at the end of this chapter).</p> |                                       |

**C291a PID Control Mode**

|              |                 |   |  |
|--------------|-----------------|---|--|
| <b>C291a</b> | <b>Range</b>    | 0 ÷ 7   | 0: Standard SUM<br>1: Standard DIFF<br>2: Average<br>3: Minimum<br>4: Maximum<br>5: 2-Zone MIN<br>6: 2-Zone MAX<br>7: 2 PIDs |
|              | <b>Default</b>  | 0   | 0: Standard SUM  |
|              | <b>Level</b>    | ENGINEERING   |  |
|              | <b>Address</b>  | 1295  |  |
|              | <b>Function</b> | <p>This parameter sets the PID control mode.</p> <p>Functions 0 to 4 set the processing mode of the feedback signal as detailed below.</p> <p>1) If <b>C179 Input for Source Selection = 0: Disabled</b>:</p> <p><b>STANDARD SUM</b>: All the selected feedback signals are summed up.<br/> <b>STANDARD DIFF</b>: The sum of the remaining selected feedback signals is subtracted from the feedback signal programmed in <b>C288</b>.<br/> <b>AVERAGE</b>: The resultant of the feedback is given from the arithmetical average of the selected signals.<br/> <b>MINIMUM</b>: The signal having the smallest value among the selected signals is considered as the feedback.<br/> <b>MAXIMUM</b>: The signal having the largest value among the selected signals is considered as the feedback.</p> <p>2) If <b>C179</b> is enabled:</p> <p><b>STANDARD SUM</b>: <b>C288+C290</b> or <b>C289+C290</b>.<br/> <b>STANDARD DIFF</b>: <b>C288-C290</b> or <b>C289-C290</b>.<br/> <b>AVERAGE</b>: <b>AVG(C288,C290)</b> or <b>AVG(C289,C290)</b>.<br/> <b>MINIMUM</b>: <b>MIN(C288,C290)</b> or <b>MIN(C289,C290)</b>.<br/> <b>MAXIMUM</b>: <b>MAX(C288,C290)</b> or <b>MAX(C289,C290)</b>.</p> <p>The references are always summed with each other, unless they are managed with the Source Selection (see <b>C179</b>).</p> |  |

|  |          |  |
|--|----------|--|
|  | Function | <p>Functions 5 and 6 (2-Zone Mode) automatically disable the Source Selection function that can be programmed with <b>C179</b>.</p> <p>In functions 5 and 6 only the references selected with <b>C285-C286</b> and the feedback values selected with <b>C288-C289</b> are used.<br/> <b>2-Zone MIN:</b> The PID operates on the system with the larger algebraic error <math>MAX(C285-C288, C286-C289)</math>. This means that the system takes control of the PID having the minimum feedback in respect to its setpoint.<br/> <b>2-Zone MAX:</b> The PID operates on the system with the smaller algebraic error <math>MIN(C285-C288, C286-C289)</math>. This means that the system takes control of the PID having the maximum feedback in respect to its reference.</p> <p><b>NOTE:</b> When <b>C171a Input for PID Control Selection</b> is activated and the selected input is activated, the 2-zone (MIN or MAX) mode is disabled and the PID always operates on the error resulting from <b>C285-C288</b>.</p> |
|  |          | <p>Function 7 (Two PIDs programming) automatically disables the Source Selection function that can be programmed with <b>C179</b>.</p> <p>The two PIDs use only the signals selected with <b>C285/C288</b> for PID and with <b>C286/C289</b> for PID2.<br/> <b>2 PID:</b> PID and PID2 operate in parallel; the outputs of the two PIDs are matched based on the configuration of <b>C171a</b>:<br/>                 If <b>C171a = 0: Disabled</b>, the outputs of the two PIDs are summed to each other;<br/>                 If <b>C171a</b> is enabled, the output of the PID regulator depends on the logic state of the configured input: 0 → PID, 1 → PID2.</p>  |

**C291b PID2 Operating Mode**

|              |          |  |                         |
|--------------|----------|--|-------------------------|
| <b>C291b</b> | Range    | 1 ÷ 2  | 1: Normal<br>2: Inverse |
|              | Default  | 1  | 1: Normal               |
|              | Level    | ENGINEERING  |                         |
|              | Address  | 1296   |                         |
|              | Function | This parameter sets how to calculate the PID2 output.<br>Two modes are available: 1: <b>Normal</b> , 2: <b>Inverse</b> .<br>In <b>Normal</b> mode, the output of the PID regulator is the actual PID2 output.<br>If 2: <b>Inverse</b> is selected, the error sign is reversed.<br>The Inverse operating mode can be used for special applications only (see Keeping Fluid Level Constant (Example)). |                         |

**C292 Selection of the Variable for Calculating the Derivative Term**

|             |          |   |                        |
|-------------|----------|---|------------------------|
| <b>C292</b> | Range    | 0 ÷ 1   | 0: Measure<br>1: Error |
|             | Default  | 0   | 0: Measure             |
|             | Level    | ENGINEERING   |                        |
|             | Address  | 1292  |                        |
|             | Function | This parameter sets the variable used for calculating the derivative term.<br>By default, the derivative term is computed according to the feedback measure, but it can also be computed according to the PID error:<br>Error = Reference – Feedback. |                        |

**C293 Proportional Multiplier of Derivative and Integral Terms**

|             |                 |   |                 |
|-------------|-----------------|---|-----------------|
| <b>C293</b> | <b>Range</b>    | 0 ÷ 1   | 0: No<br>1: Yes |
|             | <b>Default</b>  | 0   | 0: No           |
|             | <b>Level</b>    | ENGINEERING   |                 |
|             | <b>Address</b>  | 1293  |                 |
|             | <b>Function</b> | This parameter defines if the proportional term is used for the multiplication of the derivative and integral terms as well.<br>0: No means that the proportional term DOES NOT multiply the integral term. |                 |

**C294 PID Action**

|             |                |             |  |
|-------------|----------------|-------------|--|
| <b>C294</b> | <b>Range</b>   | 0 ÷ 4       | 0: External output<br>1: Reference<br>2: Reference sum<br>3: Voltage sum<br>4: Full Ref. Sum |
|             | <b>Default</b> | 1           | 1: Reference   |
|             | <b>Level</b>   | ENGINEERING |  |
|             | <b>Address</b> | 1294        |  |
|             |                |             |  |

## Function

This parameter sets the type of implementation carried out by the PID regulator.  
**C294 = External Output:** The PID regulator is independent of the drive operation, unless a digital input is configured for PID disabling; if the digital input closes, the PID regulator is disabled and the output is set to zero. In order to use the PID regulator output externally to the drive, configure one of the analog outputs as PID Out.

**C294 = Reference:** The PID regulator output is the speed/torque reference of the connected motor (depending on the type of reference configured when the motor is running); any other reference source which will be selected will be ignored. If the output is a speed reference, 100% corresponds to the max. absolute value between min. speed and max. speed set for the motor being used.

Mot1  $\leftarrow$  Max { | **C028** |; | **C029** | }

Mot2  $\leftarrow$  Max { | **C071** |; | **C072** | }

Mot3  $\leftarrow$  Max { | **C114** |; | **C115** | }

If the output is a torque reference, 100% is the max. absolute value between the min. limit and the max. limit of the torque of the active motor.

Mot1  $\leftarrow$  max { | **C047** |; | **C048** | }

Mot2  $\leftarrow$  max { | **C090** |; | **C091** | }

Mot3  $\leftarrow$  max { | **C133** |; | **C134** | }

**C294 = Add Reference:** The PID regulator output is a correction of the speed/torque reference of the active motor (depending on the type of reference configured when the motor is running). The percentage value of the PID output relates to the instant value of the speed/torque reference. For example, if the speed reference of the active motor is 800rpm and the PID output is ignored, if this drops to 50%, the overall speed setpoint will be  $800 + 800 \cdot (50/100) = 1200$ rpm. Therefore, the PID regulator can never reversed the reference sign.

**C294 = Add Voltage Out:** This configuration is active only when the control algorithm of the active motor is IFD. In this case, the PID regulator output is a correction of the output voltage. The percentage value of the PID output relates to the instant voltage value.

For example, if a motor is operating in IFD mode and the drive output voltage is 200V rms at 25 Hz with PID Output = 0, if PID Output drops to -10%, the actual voltage will be  $200 + 200 \cdot (-10/100) = 180$ V.

Another possible usage is the voltage drop compensation on a filter (if any) installed between the drive and the motor. To do so, set (**C285**, **C286**, **C287**) 9: Vout as a reference, and (**C288**, **C289**, **C290**) 13: Vout measured as a feedback. Two properly transformed phases are to be linked to analog inputs **AIN1** e **AIN2** downstream of the filter, in order to exploit the voltage actually delivered to the motor as the feedback. Only when **C285**, **C286** or **C287** are set to 9: Vout, the value percent of the PID output is referred to the nominal voltage. See "Example of Compensation of Voltage Drop in a Filter" at the end of this section.

**C294 = Add Reference Full:** The regulator output is a correction of the speed/torque reference of the connected motor (depending on the type of reference configured for the active motor). The value percent of the PID output is managed in the same way as **C294 = Reference** and is summed to the main reference.

For example, if a motor is speed-controlled with **C029**=1500rpm, considering the PID regulator output as null, the reference is 400rpm; if the PID output becomes 50%, the total speed setpoint is  $400 + 1500 \cdot (50/100) = 1150$ rpm.

In that way, if the PID output is other than zero, the reference generated will be other than zero as well, even if the main reference is null, unlike what would happen if **C294 = Add Reference**.

### 46.4. Keeping Fluid Level Constant (Example)

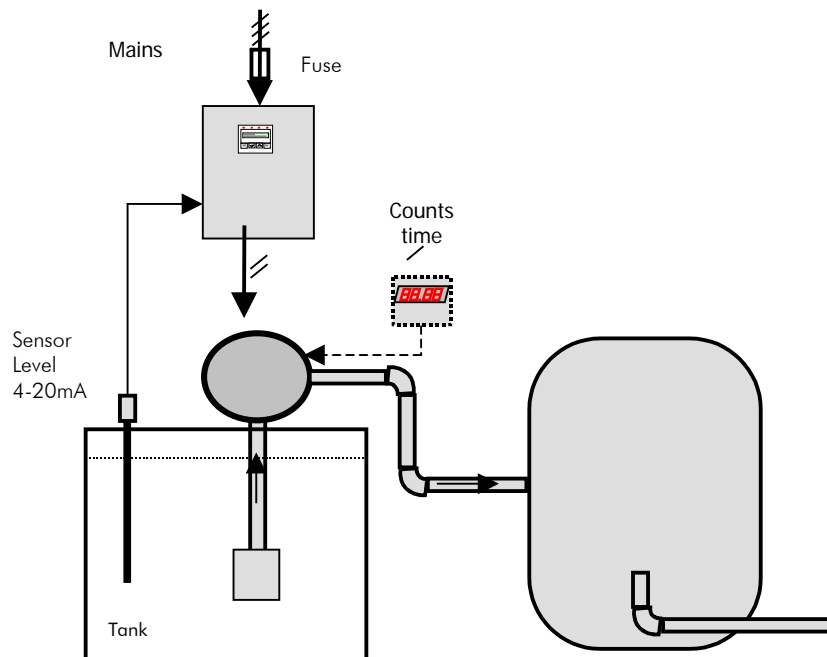

Figure 68: Keeping fluid level constant (Example)

Suppose that the maximum level in the tank is to be kept at 50% and that a 4–20mA level probe is used, with an output of 4mA for the min. level and 20mA for the max. level. The PID reference is sent from keypad, while the probe feedback is sent to AIN2/PTC analog input, which is configured as follows:

|   |   |   |   |                      |
|---|---|---|---|----------------------|
| R | W | S | P060-Type of Reference for Input AIN2/PTC       | 2: 4-20mA [SW1-3 On] |
| R | W | S | P061-Reference Minimum Value for Input AIN2/PTC | 4.0 mA               |
| R | W | S | P062-Reference Maximum Value for Input AIN2/PTC | 20.0 mA              |
| R | W | S | P063-Offset for Input AIN2/PTC                  | 0.000 mA             |
| R | W | S | P064-Filter AIN2/PTC Constant                   | 5 ms                 |

The reference shall be saved from keypad, thus avoiding setting it up again when the drive is shut off.

|   |   |   |   |             |
|---|---|---|---|-------------|
| R | W | S | P068-Storage of UP/DN values at Power Off                   | 1: Yes      |
| R | W | S | P068a-Reset of Speed/Torque UP/DN value at Stop             | 0: No       |
| R | W | S | P068b-Reset of PID UP/DN value at Stop                      | 0: No       |
| R | W | S | P068c-Reset of Speed/Torque UP/DN value at Source Selection | 0: No       |
| R | W | S | P068d-Reset of PID UP/DN value at Source Selection          | 0: No       |
| R | W | S | P069-Amplitude of UP/DN and KPD Reference                   | 1: Unipolar |

The PID regulator action and the PID output computing mode must also be set.

|          |   |   |  |                 |
|----------|---|---|--|-----------------|
| R        | W | S | C285-Selection of Reference Type 1 PID                         | 2: AIN1 [5-6]   |
| R        | W | S | C286-Selection of Reference Type 2 PID                         | 0: Disabled     |
| R        | W | S | C287-Selection of Reference Type 3 PID                         | 0: Disabled     |
| R        | W | S | C288-Selection of Feedback Type 1 PID                          | 3: AIN2 [7-8]   |
| R        | W | S | C289-Selection of Feedback Type 2 PID                          | 0: Disabled     |
| R        | W | S | C290-Selection of Feedback Type 3 PID                          | 0: Disabled     |
| R        | W | S | C291-PID Operating Mode  | 1: Normal       |
| R        | W | S | C291a-PID Control Mode   | 0: Standard SUM |
| <b>R</b> | W | S | C291b-PID2 Operating Mode                                      | 1: Normal       |
| R        | W | S | C292-Quantity Selection to Compute Derivative Term             | 0: Measure      |
| R        | W | S | C293-Kp Used as a Multiplier for Integral and Derivative Terms | 0: No           |
| R        | W | S | C294-PID Operation   | 1: Reference    |

The PID regulator parameters are defined in the PID PARAMETERS MENU. This configuration limits the PID output between 0 and 100% for a proper rotation of the connected pump. Set **P255** = 1000 ts: if the PID output is equal to the min. value for 5 seconds, the drive is put on stand-by.

|   |   |   |   |             |             |
|---|---|---|---|-------------|-------------|
| R | W | S | P236-PID Maximum Output   | 100.00      | %           |
| R | W | S | P237-PID Minimum Output   | 0.00        | %           |
| R | W | S | P237a-Wake-Up mode for PID                                      | 0: Disabled |             |
| R | W | S | P237b-Wake-Up level for PID                                     | 0.00        | %           |
| R | W | S | P238-Maximum Value of PID Integral Term                         | 100.00      | %           |
| R | W | S | P239-Maximum Value of PID Derivative Term                       | 100.00      | %           |
| R | W | S | P240-Proportional Coefficient Value                             | 5.000       |             |
| R | W | S | P241-Proportional Term Multiplicative Factor                    | 0: 1        |             |
| R | W | S | P242-Integral Time (Multiples of Tc)                            | 500         | Tc Disabled |
| R | W | S | P243-Derivative Time (Multiples of Tc/1000)                     | 0           | mTc         |
| R | W | S | P244-Cycle Time Tc  | 5           | ms          |
| R | W | S | P245-PID Reference Min. Value                                   | -100.00     | %           |
| R | W | S | P246-PID Reference Max. Value                                   | 100.00      | %           |
| R | W | S | P247-PID Feedback Minimum Value                                 | -100.00     | %           |
| R | W | S | P248-PID Feedback Maximum Value                                 | 100.00      | %           |
| R | W | S | P249-PID Ramp UP Acceleration Time                              | 0.00        | s           |
| R | W | S | P250-PID Ramp DOWN Deceleration Time                            | 0.00        | s           |
| R | W | S | P251-Unit of Measure for PID Ramps                              | 2: 1 s      |             |
| R | W | S | P252-Start S-Curve for PID Ramps                                | 1           | %           |
| R | W | S | P253-End S-Curve for PID Ramps                                  | 1           | %           |
| R | W | S | P254-PID Out Threshold Enabling Integral Implem.                | 0.0         | % Refmax    |
| R | W | S | P255-Inverter Disabling Time for PID Output Equal to Min. Value | 5           | s Disabled  |
| R | W | S | P256-Time Spent by PID Output from 0% to 100%                   | 1           | ms          |

When the level of liquid in the tank exceeds the reference value set from keypad, a negative error is produced (Error = Reference – Feedback). Because the complemented output computing mode is selected and because the complemented output is the speed reference, the higher the error absolute value, the higher the PID output value. This means that the quicker the level increases, the quicker the pump suction. On the other hand, if the level is lower than the reference, a positive error is produced, because the PID output is limited to 0%, the pump will not activate; if the PID output is equal to the min. value for a timer longer than  $P255 = 1000 * P244 = 5\text{sec}$ , the drive is put on stand-by.

## 46.5. Example of Compensation of Voltage Drop in a Filter

Assume that a sinusoidal filter is installed between the Penta Drive and the motor. The drive output voltage is to be adjusted to compensate for voltage drop caused by that filter. The following can be used as a feedback signal:

- 1) an analog input, connected to a signal proportional to RMS voltage, downstream of the filter, obtained by transforming and rectifying one of the phases;
- 2) two analog inputs, connected to two signals obtained by transforming two of the phases, utilized by the system to compute the RMS voltage value (see **M051a**).

### 46.5.1. VOLTAGE DROP COMPENSATION – FEEDBACK FROM SINGLE ANALOG INPUT

Assume that a 0-10V voltage signal proportional to RMS voltage downstream of the filter is available and that 50Vrms correspond to 1V. This signal is linked to analog input **AIN1**. The rated motor voltage (**C019**) is assumed to be 400V.

Set the following in the PID CONFIGURATION MENU:

|             |                              |                       |
|-------------|------------------------------|-----------------------|
| <b>C285</b> | Selection of PID Reference 1 | 9: V out              |
| <b>C288</b> | Selection of PID Feedback 1  | 2: AIN1               |
| <b>C291</b> | PID Operation                | 1: Normal             |
| <b>C294</b> | PID Feedback                 | 3: Add Voltage Output |

Set the following in the INPUTS FOR REFERENCES MENU:

|             |                                       |          |
|-------------|---------------------------------------|----------|
| <b>P055</b> | Type of Reference for AIN1 Input      | 3: 0-10V |
| <b>P057</b> | Ref. Max. Value Limits for AIN1 Input | 10.0V    |

Set the following in the PID PARAMETERS MENU:

|             |                                |          |
|-------------|--------------------------------|----------|
| <b>P236</b> | Max. PID Output                | 100.00%  |
| <b>P237</b> | Min. PID Output                | 0.00%    |
| <b>P240</b> | Proportional Coefficient Value | 1.000    |
| <b>P242</b> | Integral Time                  | Disabled |
| <b>P245</b> | PID Reference Min. Value       | 0.00%    |
| <b>P246</b> | PID Reference Max. Value       | 125.00%  |

The selection criterion of parameters **P057** and **P246** is the following as per the hypothesis above: 10V for **AIN1** correspond to 500Vrms, i.e. 125% of the rated motor voltage set in **C019**.

The compensated output voltage will be as follows:

$V_{out} = V_d + V_{mot} * PID_{out}$ , where:

$V_d$  is the voltage that could be delivered without compensation,

$V_{mot}$  is the rated motor voltage (**C019**),

$PID_{out}$  is the PID output, given by  $(V_{ref} - V_{fbk})/V_{mot}$ .

## 46.5.2. VOLTAGE DROP COMPENSATION - FEEDBACK FROM TWO ANALOG INPUTS

Assume that two  $\pm 10V$  voltage signals proportional to the instantaneous voltage of two phases downstream of the filter are present and that 100V correspond to 1V. Those signals are linked to analog inputs **AIN1** and **AIN2**. Assume that the rated motor voltage (**C019**) is 400V. If the voltage downstream of the filter is a sinusoidal voltage, the voltage sinusoids will be  $400 \cdot \text{SQRT}(2) = 565V$  at a rated voltage of 400Vrms. The amplitude of signals **AIN1** and **AIN2**, damped 1:100, will be 5.65V, i.e. within the allowable range.

Set the following in the PID CONFIGURATION MENU:

|             |                              |                       |
|-------------|------------------------------|-----------------------|
| <b>C285</b> | Selection of PID Reference 1 | 9: V out              |
| <b>C288</b> | Selection of PID Feedback 1  | 13: V out measured    |
| <b>C291</b> | PID Operation                | 1: Normal             |
| <b>C294</b> | PID Feedback                 | 3: Add Voltage Output |

Set the following in the INPUTS FOR REFERENCES MENU:

|             |  |              |
|-------------|--|--------------|
| <b>P055</b> | Type of Reference for AIN1 Input             | 0: $\pm 10V$ |
| <b>P057</b> | Ref. Max. Value Limits for AIN1 Input        | 8.0V         |
| <b>P060</b> | Type of Reference for AIN2 Input             | 0: $\pm 10V$ |
| <b>P062</b> | AIN2 Input Value Producing Maximum Reference | 8.0V         |

Set the following in the PID PARAMETERS MENU:

|             |                                |          |
|-------------|--------------------------------|----------|
| <b>P236</b> | Max. PID Output                | 100.00%  |
| <b>P237</b> | Min. PID Output                | 0.00%    |
| <b>P240</b> | Proportional Coefficient Value | 1.000    |
| <b>P242</b> | Integral Time                  | Disabled |
| <b>P245</b> | PID Reference Min. Value       | 0.00%    |
| <b>P246</b> | PID Reference Max. Value       | 200.00%  |

The selection criterion of parameters **P057** and **P246** is the following as per the hypothesis above: 8Vrms in **AIN1** and **AIN2** correspond to 800Vrms, i.e. 200% of the rated motor voltage set in **C019**. The upper limit for parameter **P246** is 200%, so **P057** = 10.00V, **P247** =  $1000/400 = 250\%$ , equivalent from a numerical point of view, would not be possible.

The compensated output voltage will be as follows:

$V_{out} = V_d + V_{mot} \cdot \text{PID}_{out}$ , where:

$V_d$  is the voltage delivered without compensation,

$V_{mot}$  is the rated motor voltage (**C019**),

$\text{PID}_{out}$  is the PID output, given by  $(V_{ref} - V_{fbk})/V_{mot}$ .

## 47. BRIDGE CRANE MENU

### 47.1. Overview

For lifting applications, it may be necessary to consider the opening/closing of a mechanical brake in order to obtain a proper control of the connected motor.

For example, if a mechanical brake takes 500ms to open after the start command – the delay is due to the type of brake – the motor will not be running for 500ms, while the speed reference increases the preset ramp. The motor then pushes against the brake, and when it can rotate freely, the motor torque will not match with the torque required to move the connected load.

If the speed setpoint is kept to zero for a given time after sending the start command (considering the time required for the mechanical brake to open), the motor control will implement the proper torque for the motor speed as soon as the motor can start rotating.

The brake closure can be controlled via a digital input that is properly set up; when the drive detects the brake closure, it automatically adjusts the value of the current injected into the motor to the fluxing value. This is required when, during the lifting stage, the mechanical brake closes when the load is suspended after reaching negligible speed. In that case, the torque produced by the motor is capable of keeping the load hanging; when the brake closes, this has no effect on the speed regulator, because the motor is already standstill. When the brake closes, no torque must be generated to keep the load hanging, so the current injected into the motor drops to the value required for the motor fluxing.



**NOTE** The Bridge CRANE menu is used for VTC and FOC Control only.



**NOTE** For safety reasons, the brake closure contact must be an NO contact (closed contact only when the brake is engaged).



**NOTE** In addition to parameters **C300** to **C302**, a dedicated MDO must be set as 6: BRAKE (see the DIGITAL OUTPUTS MENU).

### 47.2. List of Parameters C300 to C303

Table 117: List of parameters C300 to C303

| Parameter    | FUNCTION                                     | User Level  | MODBUS Address | DEFAULT VALUES |
|--------------|--|-------------|----------------|----------------|
| <b>C300</b>  | Positive pretensioning torque [%Cmot]        | ENGINEERING | 1300           | 0.0%           |
| <b>C301</b>  | Positive pretensioning torque time           | ENGINEERING | 1301           | 0ms            |
| <b>C300a</b> | Negative pretensioning torque [%Cmot]        | ENGINEERING | 1308           | 0.0%           |
| <b>C301a</b> | Time period of negative pretensioning torque | ENGINEERING | 1309           | 0ms            |
| <b>C302</b>  | Closed brake input (NO contact)              | ENGINEERING | 1302           | 0: None        |
| <b>C303</b>  | Brake activation during Tracking Error       | ENGINEERING | 1304           | 1: Yes         |

**C300/C300a Pretensioning Torque [%Cmot]**

|                   |                 |   |                   |
|-------------------|-----------------|---|-------------------|
| <b>C300/C300a</b> | <b>Range</b>    | -5000 ÷ +5000   | -500.0% ÷ +500.0% |
|                   | <b>Default</b>  | 0   | 0.0 %             |
|                   | <b>Level</b>    | ENGINEERING   |                   |
|                   | <b>Address</b>  | 1300/1308   |                   |
|                   | <b>Control</b>  | VTC and FOC   |                   |
|                   | <b>Function</b> | <p>If not set to zero, this parameter defines the torque value (expressed as a percentage of the rated torque of the selected motor) reached before the speed ramp starts after sending a <b>START</b> command.</p> <p>After sending a <b>START</b> command, the drive brings the motor torque to the level set in <b>C300/C300a</b> and torque is adjusted by the speed loop for the time set in <b>C301/C301a</b> in order to keep the motor standstill. Once this time has elapsed, the speed ramp can start and the motor follows the required speed profile.</p> <p>The torque sign defines the running direction.</p> <p>The sign of the speed reference determines which value percent is to be used; <b>C300</b> is for the positive sign, <b>C300a</b> is for the negative sign.</p> |                   |

**C301/C301a Pretensioning Torque Time**

|                   |                 |   |              |
|-------------------|-----------------|---|--------------|
| <b>C301/C301a</b> | <b>Range</b>    | 0 ÷ 32000   | 0 ÷ 32000 ms |
|                   | <b>Default</b>  | 0   | 0            |
|                   | <b>Level</b>    | ENGINEERING   |              |
|                   | <b>Address</b>  | 1301/1309   |              |
|                   | <b>Control</b>  | VTC and FOC   |              |
|                   | <b>Function</b> | <p>Delay time passing between the start command and the speed ramp start. During this time, the motor torque output is set in <b>C300/C300a</b> to keep the load suspended.</p> |              |

**C302 Closed Brake Input (NO contact)**

|             |                 |  |   |
|-------------|-----------------|--|---|
| <b>C302</b> | <b>Range</b>    | 0 ÷ 12<br>0 ÷ 20 if ES847 or ES870 is installed  | 0 → Inactive<br>1 ÷ 8 → MDI1 ÷ MDI8<br>9 ÷ 12 → MPL1 ÷ MPL4<br>13 ÷ 16 → TFL1 ÷ TFL4<br>17 ÷ 24 → XMDI1 ÷ XMDI8 |
|             | <b>Default</b>  | 0  | 0 → Inactive  |
|             | <b>Level</b>    | ENGINEERING  |   |
|             | <b>Address</b>  | 1302   |   |
|             | <b>Control</b>  | VTC and FOC  |   |
|             | <b>Function</b> | <p>This parameter determines the digital input assigned to the mechanical brake closure feedback (NO contact, which closes only when the brake is engaged). When the brake closure is detected after a deceleration ramp, the current required for motor fluxing is injected into the motor. If no digital input is available for the detection of the brake closure, set max. time in <b>C183</b>, in order to avoid injecting current into the motor after the deceleration ramp. When the motor is not running, the <b>START</b> command is disabled and the speed setpoint is at zero for a time longer than the one set in <b>C183</b>, the drive will be put on standby.</p> |   |

**C303 Brake Activation during Tracking Error**

|             |                 |  |                 |
|-------------|-----------------|--|-----------------|
| <b>C303</b> | <b>Range</b>    | 0 ÷ 1  | 0: No<br>1: Yes |
|             | <b>Default</b>  | 1  | 1: Yes          |
|             | <b>Level</b>    | ENGINEERING  |                 |
|             | <b>Address</b>  | 1304   |                 |
|             | <b>Control</b>  | VTC and FOC  |                 |
|             | <b>Function</b> | <p>This parameter defines if, in case of tracking error (ENCODER/FREQUENCY INPUTS MENU, parameters <b>C192</b>, <b>C193</b>, <b>C194</b>), the output of the electromechanical brake is to be disabled, thus causing the activation of the brake itself.</p> <p>0: No, in case of tracking error, the brake command output is kept active.<br/>1: Yes, in case of tracking error, the brake command output is deactivated, thus causing the brake activation.</p> <p>If <b>C194</b>=1 (or =2 in some cases), the tracking error triggers alarm <b>A080</b>. In case of alarm, the brake output is disabled, independently of the value in <b>C303</b>.</p> |                 |

## 48. DATE AND TIME MENU

### 48.1. Overview

The Clock/Calendar of the control board (RTC – Real Time Clock) is based on the Clock/Calendar of the Data Logger ES851 (please refer to the Installation Guide).



**NOTE**

The Data and Time Menu may be accessed only if the Data Logger board is installed (even the ES851 RTC version only) and if parameter **R021** Data Logger setting is set to 2: ENABLE.

The clock/calendar can be updated via special parameters. The display/keypad permits to immediately update the clock/calendar: just select the Set Time page or the Set Date page and press **ENTER**. Press **ESC** to go to the next field; press **ENTER** to confirm.

If you use the serial link of the inverter where the Data Logger is installed, the Clock/Calendar is viewed in the measure parameters below. To update the Clock/Calendar via serial link, set the new values in **C310** to **C315** and send the edit command (**C316**).

Parameters **R050** to **R053** set the rules for daylight saving time.

Press Save/Enter for TIME setting

```

C 3 1 4   S e t   T I M E
D S T :   O F F
>
          1 6 : 2 9 : 5 5
2 0 1 1 / J A N / 0 1 : S A T
        
```

First page of the Date and Time menu on the display/keypad

Press Save/Enter for DATE setting

```

C 3 1 0   S e t   D A T E
          1 6 : 2 9 : 5 5
> 2 0 1 1 / J A N / 0 1 : S A B
        
```

Second page of the Date and Time menu on the display/keypad

The date and time on the display/keypad are represented by the measures below:

**Time (Hours)**

|                     |                 |   |              |
|---------------------|-----------------|---|--------------|
| <b>Time (Hours)</b> | <b>Range</b>    | 0 ÷ 23  | 0 ÷ 23 hours |
|                     | <b>Active</b>   | This measure is available only if the Data Logger ES851 is installed and activated ( <b>R021</b> = ENABLE). |              |
|                     | <b>Address</b>  | 3342  |              |
|                     | <b>Level</b>    | BASIC   |              |
|                     | <b>Function</b> | Time - hours (current value).   |              |

Minutes

|                |                 |   |            |
|----------------|-----------------|---|------------|
| <b>Minutes</b> | <b>Range</b>    | 0 ÷ 59  | 0 ÷ 59 min |
|                | <b>Active</b>   | This measure is available only if the Data Logger ES851 is installed and activated ( <b>R021</b> = ENABLE). |            |
|                | <b>Address</b>  | 3343  |            |
|                | <b>Level</b>    | BASIC   |            |
|                | <b>Function</b> | Minutes (current value).  |            |

Seconds

|                |                 |   |            |
|----------------|-----------------|---|------------|
| <b>Seconds</b> | <b>Range</b>    | 0 ÷ 59  | 0 ÷ 59 sec |
|                | <b>Active</b>   | This measure is available only if the Data Logger ES851 is installed and activated ( <b>R021</b> = ENABLE). |            |
|                | <b>Address</b>  | 3344  |            |
|                | <b>Level</b>    | BASIC   |            |
|                | <b>Function</b> | Seconds (current value).  |            |

Day of the Week

|                        |                 |   |   |
|------------------------|-----------------|---|---|
| <b>Day of the Week</b> | <b>Range</b>    | 1 ÷ 7   | 1: Mon.<br>2: Tues.<br>3: Wed.<br>4: Th.<br>5: Fri.<br>6: Sat.<br>7: Sun. |
|                        | <b>Active</b>   | This measure is available only if the Data Logger ES851 is installed and activated ( <b>R021</b> = ENABLE). |   |
|                        | <b>Address</b>  | 3345  |   |
|                        | <b>Level</b>    | BASIC   |   |
|                        | <b>Function</b> | Day of the week (current value).  |   |

Day of the Month

|                         |                 |   |             |
|-------------------------|-----------------|---|-------------|
| <b>Day of the Month</b> | <b>Range</b>    | 1 ÷ 31  | 1 ÷ 31 days |
|                         | <b>Active</b>   | This measure is available only if the Data Logger ES851 is installed and activated ( <b>R021</b> = ENABLE). |             |
|                         | <b>Address</b>  | 3346  |             |
|                         | <b>Level</b>    | BASIC   |             |
|                         | <b>Function</b> | Day of the month (current value).   |             |

Daylight Saving Time

|                             |                 |   |       |
|-----------------------------|-----------------|---|-------|
| <b>Daylight Saving Time</b> | <b>Range</b>    | 0 ÷ 2   | 0 ÷ 2 |
|                             | <b>Active</b>   | This measure is available only if the Data Logger ES851 is installed and activated ( <b>R021</b> = ENABLE). |       |
|                             | <b>Address</b>  | 528   |       |
|                             | <b>Level</b>    | BASIC   |       |
|                             | <b>Function</b> | Status of the DST:<br>0: Inactive<br>1: Inactive from less than 1 hour<br>2: Active                         |       |

Month

|              |                 |   |   |
|--------------|-----------------|---|---|
| <b>Month</b> | <b>Range</b>    | 1 ÷ 12  | 1: January<br>2: February<br>3: March<br>4: April<br>5: May<br>6: June<br>7: July<br>8: August<br>9: September<br>10: October<br>11: November<br>12: December |
|              | <b>Active</b>   | This measure is available only if the Data Logger ES851 is installed and activated ( <b>R021</b> = ENABLE). |   |
|              | <b>Address</b>  | 3347  |   |
|              | <b>Level</b>    | BASIC   |   |
|              | <b>Function</b> | Month (current value).  |   |

Year

|             |                 |   |                   |
|-------------|-----------------|---|-------------------|
| <b>Year</b> | <b>Range</b>    | 2000 ÷ 2099   | 2000 ÷ 2099 years |
|             | <b>Active</b>   | This measure is available only if the Data Logger ES851 is installed and activated ( <b>R021</b> = ENABLE). |                   |
|             | <b>Address</b>  | 3348  |                   |
|             | <b>Level</b>    | BASIC   |                   |
|             | <b>Function</b> | Year (current value).   |                   |

## 48.2. List of Parameters C310 to C316

Table 118: List of Parameters C310 to C316

| Parameter   | FUNCTION                       | User Level | MODBUS Address      |
|-------------|--------------------------------|------------|---------------------|
|             |                                |            | Drive Software (PD) |
| <b>C310</b> | Day of the week to be changed  | ADVANCED   | 1237                |
| <b>C311</b> | Day of the month to be changed | ADVANCED   | 1238                |
| <b>C312</b> | Month to be changed            | ADVANCED   | 1239                |
| <b>C313</b> | Year to be changed             | ADVANCED   | 1240                |
| <b>C314</b> | Time (Hours) to be changed     | ADVANCED   | 1241                |
| <b>C315</b> | Time (Minutes) to be changed   | ADVANCED   | 1242                |
| <b>C316</b> | Clock/Calendar editing command | ADVANCED   | 1244                |

### C310 Day of the Week to be changed

|             |                 |  |   |
|-------------|-----------------|--|---|
| <b>C310</b> | <b>Range</b>    | 1 ÷ 7  | 1: Mon.<br>2: Tues.<br>3: Wed.<br>4: Th.<br>5: Fri.<br>6: Sat.<br>7: Sun. |
|             | <b>Default</b>  | 1  | 1: Mon.   |
|             | <b>Active</b>   | This parameter can be viewed and changed only if the Data Logger ES851 is installed and activated ( <b>R021</b> = ENABLE). |   |
|             | <b>Address</b>  | 1237   |   |
|             | <b>Level</b>    | ADVANCED   |   |
|             | <b>Function</b> | This parameter sets the value of the day of the week to be changed.  |   |

### C311 Day of the Month to be changed

|             |                 |  |             |
|-------------|-----------------|--|-------------|
| <b>C311</b> | <b>Range</b>    | 1 ÷ 31   | 1 ÷ 31 days |
|             | <b>Default</b>  | 1  | Day 1       |
|             | <b>Level</b>    | ADVANCED   |             |
|             | <b>Active</b>   | This parameter can be viewed and changed only if the Data Logger ES851 is installed and activated ( <b>R021</b> = ENABLE). |             |
|             | <b>Address</b>  | 1238   |             |
|             | <b>Function</b> | This parameter sets the value of the day of the month to be changed.   |             |

**C312 Month to be changed**

|             |                 |   |   |
|-------------|-----------------|---|---|
| <b>C312</b> | <b>Range</b>    | 1 ÷ 12  | 1: January<br>2: February<br>3: March<br>4: April<br>5: May<br>6: June<br>7: July<br>8: August<br>9: September<br>10: October<br>11: November<br>12: December |
|             | <b>Default</b>  | 1   | 1: January  |
|             | <b>Level</b>    | ADVANCED  |   |
|             | <b>Active</b>   | This parameter can be viewed and changed only if the Data Logger ES851 is installed and activated ( <b>R021 = ENABLE</b> ). |   |
|             | <b>Address</b>  | 1239  |   |
|             | <b>Function</b> | This parameter sets the value of the month to be changed.   |   |

**C313 Year to be changed**

|             |                 |   |                   |
|-------------|-----------------|---|-------------------|
| <b>C313</b> | <b>Range</b>    | 2000 ÷ 2099   | 2000 ÷ 2099 years |
|             | <b>Default</b>  | 0   | Year 2000         |
|             | <b>Level</b>    | ADVANCED  |                   |
|             | <b>Active</b>   | This parameter can be viewed and changed only if the Data Logger ES851 is installed and activated ( <b>R021 = ENABLE</b> ). |                   |
|             | <b>Address</b>  | 1240  |                   |
|             | <b>Function</b> | This parameter sets the value of the year to be changed.  |                   |

**C314 Time (hours) to be changed**

|             |                 |   |              |
|-------------|-----------------|---|--------------|
| <b>C314</b> | <b>Range</b>    | 0 ÷ 23  | 0 ÷ 23 hours |
|             | <b>Default</b>  | 0   | 0 hours      |
|             | <b>Level</b>    | ADVANCED  |              |
|             | <b>Active</b>   | This parameter can be viewed and changed only if the Data Logger ES851 is installed and activated ( <b>R021 = ENABLE</b> ). |              |
|             | <b>Address</b>  | 1241  |              |
|             | <b>Function</b> | This parameter sets the time (hour) to be changed.  |              |

**C315 Minutes to be changed**

|             |                 |   |             |
|-------------|-----------------|---|-------------|
| <b>C315</b> | <b>Range</b>    | 0 ÷ 59  | 0 ÷ 59 min. |
|             | <b>Default</b>  | 0   | 0 minutes   |
|             | <b>Level</b>    | ADVANCED  |             |
|             | <b>Active</b>   | This parameter can be viewed and changed only if the Data Logger ES851 is installed and activated ( <b>R021 = ENABLE</b> ). |             |
|             | <b>Address</b>  | 1242  |             |
|             | <b>Function</b> | This parameter sets the time (minutes) to be changed.   |             |

**C316 Clock/Calendar Editing Command**

|             |                 |  |       |
|-------------|-----------------|--|-------|
| <b>C316</b> | <b>Range</b>    | 0 ÷ 1  | 0 ÷ 1 |
|             | <b>Default</b>  | 0  | 0     |
|             | <b>Level</b>    | ADVANCED   |       |
|             | <b>Active</b>   | This parameter can be viewed and changed only if the Data Logger ES851 is installed and activated ( <b>R021</b> = ENABLE).   |       |
|             | <b>Address</b>  | 1244   |       |
|             | <b>Function</b> | <p>If this parameter is set to 1, all the values set in parameters <b>C310</b> to <b>C315</b> are written and stored to the clock/calendar of the board and the measures described above are instantly changed.</p> <div style="display: flex; align-items: center;">  <div> <p><b>CAUTION</b></p> <p>Also unchanged parameters are written to the clock/calendar. Make sure that unchanged parameters are correct.</p> </div> </div> |       |

## 49. TIMED FLAGS MENU

### 49.1. Overview

The Timed Flag Menu includes the parameters setting the four timed flags for the inverter, TFL1..4. The following data items are set for each timed flag: activation time (Time ON), deactivation time (Time OFF), days of the week when activation shall occur.

The timed flags may be used as they were digital inputs, both when managing digital outputs (MDO) and when managing virtual digital outputs (MPL). It is also possible to assign the same control functions that can be associated to the other digital inputs (see DIGITAL INPUTS MENU).



**NOTE** The Timed Flags Menu may be accessed only if the Data Logger board is installed (even the ES851 RTC version only) and if parameter **R021** Data Logger setting is set to 2: ENABLE.

### 49.2. Examples

Every time flag features 3 parameters (Hour, Minute, Second) setting the activation time of the flag itself; 3 parameters (Hour, Minute, Second) setting the deactivation time of the flag itself; 1 parameter setting the days of the week when the flag shall activate. If the activation time precedes the deactivation time, the flag will have the TRUE logic value at the activation time, whilst it will have the FALSE logic value at the deactivation time in the days of the week concerned. If the activation time is subsequent to the deactivation time, the flag will have the TRUE logic value at the activation time, whilst it will have the FALSE logic value at the deactivation time of the following day.

#### Example 1:

|             |                          |         |
|-------------|--------------------------|---------|
| <b>C330</b> | TFL1: Time ON – Hour     | 08      |
| <b>C331</b> | TFL1: Time ON – Minutes  | 00      |
| <b>C332</b> | TFL1: Time ON – Seconds  | 00      |
| <b>C333</b> | TFL1: Time OFF – Hour    | 20      |
| <b>C334</b> | TFL1: Time OFF – Minutes | 00      |
| <b>C335</b> | TFL1: Time OFF – Seconds | 00      |
| <b>C336</b> | TFL1: Days of the week   | 1000000 |

The timed flag TFL1 is TRUE from 8:00:00AM to 08:00:00PM every Monday.

#### Example 2:

|             |                          |         |
|-------------|--------------------------|---------|
| <b>C330</b> | TFL1: Time ON – Hour     | 20      |
| <b>C331</b> | TFL1: Time ON – Minutes  | 00      |
| <b>C332</b> | TFL1: Time ON – Seconds  | 00      |
| <b>C333</b> | TFL1: Time OFF – Hour    | 08      |
| <b>C334</b> | TFL1: Time OFF – Minutes | 00      |
| <b>C335</b> | TFL1: Time OFF – Seconds | 00      |
| <b>C336</b> | TFL1: Days of the week   | 1000000 |

The timed flag TFL1 is TRUE from 08:00:00PM on every Monday to 8:00:00AM on every Tuesday.

### 49.3. List of Parameters from C330 to C357

Table 119: List of Parameters C330 ÷ C357

| Parameter | FUNCTION                 | User Level | DEFAULT VALUES | MODBUS Address |
|-----------|--------------------------|------------|----------------|----------------|
| C330      | TFL1: Time ON – Hour     | ADVANCED   | 0              | 271            |
| C331      | TFL1: Time ON – Minutes  | ADVANCED   | 0              | 272            |
| C332      | TFL1: Time ON – Seconds  | ADVANCED   | 0              | 273            |
| C333      | TFL1: Time OFF – Hour    | ADVANCED   | 0              | 274            |
| C334      | TFL1: Time OFF – Minutes | ADVANCED   | 0              | 275            |
| C335      | TFL1: Time OFF – Seconds | ADVANCED   | 0              | 276            |
| C336      | TFL1: Days of the week   | ADVANCED   | 0              | 277            |
| C337      | TFL2: Time ON – Hour     | ADVANCED   | 0              | 278            |
| C338      | TFL2: Time ON – Minutes  | ADVANCED   | 0              | 279            |
| C339      | TFL2: Time ON – Seconds  | ADVANCED   | 0              | 280            |
| C340      | TFL2: Time OFF – Hour    | ADVANCED   | 0              | 281            |
| C341      | TFL2: Time OFF – Minutes | ADVANCED   | 0              | 282            |
| C342      | TFL2: Time OFF – Seconds | ADVANCED   | 0              | 283            |
| C343      | TFL2: Days of the week   | ADVANCED   | 0              | 284            |
| C344      | TFL3: Time ON – Hour     | ADVANCED   | 0              | 285            |
| C345      | TFL3: Time ON – Minutes  | ADVANCED   | 0              | 286            |
| C346      | TFL3: Time ON – Seconds  | ADVANCED   | 0              | 287            |
| C347      | TFL3: Time OFF – Hour    | ADVANCED   | 0              | 288            |
| C348      | TFL3: Time OFF – Minutes | ADVANCED   | 0              | 289            |
| C349      | TFL3: Time OFF – Seconds | ADVANCED   | 0              | 290            |
| C350      | TFL3: Days of the week   | ADVANCED   | 0              | 291            |
| C351      | TFL4: Time ON – Hour     | ADVANCED   | 0              | 292            |
| C352      | TFL4: Time ON – Minutes  | ADVANCED   | 0              | 293            |
| C353      | TFL4: Time ON – Seconds  | ADVANCED   | 0              | 294            |
| C354      | TFL4: Time OFF – Hour    | ADVANCED   | 0              | 295            |
| C355      | TFL4: Time OFF – Minutes | ADVANCED   | 0              | 296            |
| C356      | TFL4: Time OFF – Seconds | ADVANCED   | 0              | 297            |
| C357      | TFL4: Days of the week   | ADVANCED   | 0              | 298            |

**C330 (C337, C344, C351) Hour of Activation of the Timed Flag TFL1 (TFL2, TFL3, TFL4)**

|                              |          |  |        |
|------------------------------|----------|--|--------|
| C330<br>C337<br>C344<br>C351 | Range    | 0 ÷ 23   | 0 ÷ 23 |
|                              | Default  | 0  | 0      |
|                              | Level    | ADVANCED   |        |
|                              | Address  | 271 (278, 285, 292)  |        |
|                              | Function | Sets the hour of activation of the timed flag <u>TFL1 (TFL2, TFL3, TFL4)</u> . |        |

**C331 (C338, C345, C352) Minute of Activation of the Timed Flag TFL1 (TFL2, TFL3, TFL4)**

|                              |          |  |        |
|------------------------------|----------|--|--------|
| C331<br>C338<br>C345<br>C352 | Range    | 0 ÷ 59   | 0 ÷ 59 |
|                              | Default  | 0  | 0      |
|                              | Level    | ADVANCED   |        |
|                              | Address  | 272 (279, 286, 293)  |        |
|                              | Function | Sets the hour of activation of the timed flag <u>TFL1 (TFL2, TFL3, TFL4)</u> . |        |

**C332 (C339, C346, C353) Second of Activation of the Timed Flag TFL1 (TFL2, TFL3, TFL4)**

|  |                 |  |        |
|--|-----------------|--|--------|
| <b>C332</b><br><b>C339</b><br><b>C346</b><br><b>C353</b> | <b>Range</b>    | 0 ÷ 59   | 0 ÷ 59 |
|  | <b>Default</b>  | 0  | 0      |
|  | <b>Level</b>    | ADVANCED   |        |
|  | <b>Address</b>  | 273 (280, 287, 294)  |        |
|  | <b>Function</b> | Sets the second of activation of the timed flag <b>TFL1 (TFL2, TFL3, TFL4)</b> . |        |

**C333 (C340, C347, C354) Hour of Deactivation of the Timed Flag TFL1 (TFL2, TFL3, TFL4)**

|  |                 |  |        |
|--|-----------------|--|--------|
| <b>C333</b><br><b>C340</b><br><b>C347</b><br><b>C354</b> | <b>Range</b>    | 0 ÷ 23   | 0 ÷ 23 |
|  | <b>Default</b>  | 0  | 0      |
|  | <b>Level</b>    | ADVANCED   |        |
|  | <b>Address</b>  | 274 (281, 288, 295)  |        |
|  | <b>Function</b> | Sets the hour of deactivation of the timed flag <b>TFL1 (TFL2, TFL3, TFL4)</b> . |        |

**C334 (C341, C348, C355) Minute of Deactivation of the Timed Flag TFL1 (TFL2, TFL3, TFL4)**

|  |                 |  |        |
|--|-----------------|--|--------|
| <b>C334</b><br><b>C341</b><br><b>C348</b><br><b>C355</b> | <b>Range</b>    | 0 ÷ 59   | 0 ÷ 59 |
|  | <b>Default</b>  | 0  | 0      |
|  | <b>Level</b>    | ADVANCED   |        |
|  | <b>Address</b>  | 275 (282, 289, 296)  |        |
|  | <b>Function</b> | Sets the minute of deactivation of the timed flag <b>TFL1 (TFL2, TFL3, TFL4)</b> . |        |

**C335 (C342, C349, C356) Second of Deactivation of the Timed Flag TFL1 (TFL2, TFL3, TFL4)**

|  |                 |  |        |
|--|-----------------|--|--------|
| <b>C335</b><br><b>C342</b><br><b>C349</b><br><b>C356</b> | <b>Range</b>    | 0 ÷ 59   | 0 ÷ 59 |
|  | <b>Default</b>  | 0  | 0      |
|  | <b>Level</b>    | ADVANCED   |        |
|  | <b>Address</b>  | 276 (283, 290, 297)  |        |
|  | <b>Function</b> | Sets the second of deactivation of the timed flag <b>TFL1 (TFL2, TFL3, TFL4)</b> . |        |

**C336 (C343, C350, C357) Days of the Week of the Activation of the Timed Flag TFL1 (TFL2, TFL3, TFL4)**

|  |                 |   |         |
|--|-----------------|---|---------|
| <b>C336</b><br><b>C343</b><br><b>C350</b><br><b>C357</b> | <b>Range</b>    | 0000000b ÷ 1111111b<br>binary   | 0 ÷ 127 |
|  | <b>Default</b>  | 0   | 0       |
|  | <b>Level</b>    | ADVANCED  |         |
|  | <b>Address</b>  | 277(284, 291, 298)  |         |
|  | <b>Function</b> | Sets the second of deactivation of the timed flag <b>TFL1 (TFL2, TFL3, TFL4)</b> .<br>Every bit corresponds to a day of the week: bit 1 corresponds to Monday, bit 7<br>corresponds to Sunday. Example:<br>1111100: flag TLF1 will activate every day of the week but Saturday and<br>Sunday.<br>0000000: the flag will never activate.<br>1111111: the flag will activate every day. |         |

## 50. SERIAL COMMUNICATIONS

### 50.1. Overview

Sinus Penta drives may be connected to other devices through a serial link. This allows reading and writing the parameters accessed through the remotable display/keypad.



Elettronica Santerno also supplies the RemoteDrive software package allowing controlling the drive through a computer connected via serial link.

The RemoteDrive offers the following functionality: image copy, keypad emulation, oscilloscope functions and multifunction tester, data logger, history data table compiler, parameter setting and data reception–transmission–storage from and to a computer, scan function for the automatic detection of the connected inverters (up to 247 connected inverters).

### 50.2. MODBUS–RTU PROTOCOL

Messages and data are sent by means of standard protocol MODBUS in RTU mode. This standard protocol performs control procedures using an 8–bit binary representation.

In RTU mode, a message begins with a silence interval equal to 3.5 times the transmission time of a character.

If the character transmission stops for a time equal to 3.5 times the transmission time of a character, the controller will consider this time interval as the end of the message. Similarly, a message starting with a shorter silence time is considered as part of the previous message.

| Message beginning | Address | Function | Data       | Error control | End of message |
|-------------------|---------|----------|------------|---------------|----------------|
| T1–T2–T3–T4       | 8 bits  | 8 bits   | n x 8 bits | 16 bits       | T1–T2–T3–T4    |

Use parameter R004 (TimeOut) to increase the silence time interval up to max. 10000ms for the systems that do not recognize standard timeouts.

#### Address

The address field acknowledges any value ranging from 1 to 247 as the address of the slave peripheral device. The master device queries the peripheral device specified in the address field; the peripheral device will respond with a message containing its address to let the master device know which the slave source of the response is. A master device query with a 0 address is addressed to all slave devices, which will not respond at all (broadcast mode).

#### Function

The function related to the message may be chosen within the legal field ranging from 0 to 255. A response of the slave device to a message of the master device will simply return the function code to the master device if no error took place; otherwise, the most significant bit in this field is set to 1.

The only functions allowed are **03h: Read Holding Register** and **10h: Preset Multiple Register** (see below).

**Data**

The data field contains any additional information for the function being used.

**Error Control**

The error control is performed through the CRC (Cyclical Redundancy Check) method. The 16-bit value of the relevant field is computed when the message is sent by the transmitter and is then re-computed and checked by the receiver.

CRC Register is computed as follows:

1. CRC Register is set to FFFFh
2. Exclusive OR is executed between CRC register and the first 8 bits of the message; the result is saved to a 16-bit register.
3. This register is right-shifted of one place.
4. If the right bit is 1, exclusive OR is executed between the 16-bit register and value 101000000000001b.
5. Steps 3 and 4 are repeated until 8 shifts are performed.
6. Exclusive OR is performed between the 16-bit register and the next 8 bits of the message.
7. Steps 3 to 6 are repeated until all message bytes are processed.
8. The result is a CRC, that is attached to the message by sending the less significant byte as the first byte.

**Supported Functions**

**03h: Read Holding Register**

Allows reading the register state of the slave device. This function does not allow the broadcast mode (address 0).

Additional parameters are the address of the basic digital register to be read and the output number to be read.

| QUERY                   | RESPONSE         |
|-------------------------|------------------|
| Slave address           | Slave address    |
| 03h Function            | 03h Function     |
| Register address (high) | Byte number      |
| Register address (low)  | Data             |
| Register N. (high)      | ...              |
| Register N. (low)       | Data             |
| Error correction        | Error correction |

**10h: Preset Multiple Register**

Sets the state of multiple registers for the slave device. In broadcast mode (address 0), the state of those registers is set in all the connected slave devices. Additional parameters are the basic register address, the number of registers to be set, the relevant value and the number of bytes used for the data items.

| QUERY                 | RESPONSE              |
|-----------------------|-----------------------|
| Slave address         | Slave address         |
| 10h Function          | 10h Function          |
| Register 1 addr. (Hi) | Register 1 addr. (Hi) |
| Register 1 addr. (Lo) | Register 1 addr. (Lo) |
| Register N. (Hi)      | Register N. (Hi)      |
| Register N. (Lo)      | Register N. (Lo)      |
| Byte number           | Error correction      |
| Data (Hi)             |                       |
| Data (Lo)             |                       |
| ...                   |                       |
| Data (Hi)             |                       |
| Data (Lo)             |                       |
| Error correction      |                       |

### Error Messages

If a message error is detected, the inverter will send a message to the master:

| Slave address | Function (MSB = 1) | Error code | Error correction |
|---------------|--------------------|------------|------------------|
|---------------|--------------------|------------|------------------|

The error code meaning is the following:

| Code |                      | DESCRIPTION   |
|------|----------------------|---|
| 0x01 | ILLEGAL FUNCTION     | The function sent by the Master is different from 0x03 (Read Holding Registers) and 0x10 (Preset Multiple Registers).   |
| 0x02 | ILLEGAL ADDRESS      | The Master wrote to or read from an illegal address.  |
| 0x03 | ILLEGAL DATA VALUE   | The numerical value the Master tried to write is not included in the correct range.   |
| 0x06 | DEVICE BUSY          | The drive refused the Master writing attempt (e.g. because it is running and a Cxxx parameter is activated).  |
| 0x07 | ANOTHER USER WRITING | Other users are writing to the selected parameter when the Master is trying to write to this parameter (e.g. display/keypad in editing mode or Upload/Download to/from keypad).     |
| 0x09 | BAD ACCESS LEVEL     | The parameter the Master is trying to write to is not included in the selected User Level (e.g. it is trying to write an ADVANCED parameter when the BASIC user level is selected). |

## 51. SERIAL LINKS MENU

### 51.1. Overview

---



**NOTE** Please refer to the Sinus Penta's Installation Guide for the description of the serial links and connections.



**NOTE** For a greater immunity against communication interference, an optional optoisolated serial board (ES822) may be used instead of RS485 serial link. Serial links RS232 and RS485 can interface with ES822 board. Please refer to the Sinus Penta's Installation Guide for the description of the optional optoisolated board.



**NOTE** The parameters described in this menu are **Rxxx** parameters. Once changed and saved, they become active only when the drive is next switched on or when the control board is reset (by holding down the **RESET** key for more than 5 secs).

Drives of the SINUS PENTA series may be connected to peripheral devices through a serial link. This enables both reading and writing of all parameters normally accessed through the display/keypad. Two-wire RS485 is used, which ensures better immunity against disturbance even on long cable paths, thus reducing the communication errors.

Two serial links are available. **Serial Link 0** is provided with a 9-pole, male D connector; **Serial Link 1** is provided with an RJ45 connector (or a three-phone connector) connected to the display/keypad.



**NOTE** The display/keypad connected through RJ45 connector dialogues correctly with the drive using the default values preset in the parameter set for serial link 1.

The drive will typically behave as a slave device (i.e. it only answers to queries sent by another device). A master device (typically a computer) is then needed to start serial communications.

The following items may be configured for both serial links:

1. The drive MODBUS address.
2. The drive response delay to a Master query.
3. The baud rate of the serial link (expressed in bits per second);
4. The time added to the 4 byte-time;
5. The serial link watchdog (which is active if the relevant parameter is not set at 0);
6. The type of parity used for serial communications.

#### 51.1.1. WATCHDOG ALARMS

**The Watchdog alarms determined by the serial link may be the following:**

- **A061** Serial alarm n.0 WDG
- **A062** Serial alarm n.1 WDG
- **A081** Keypad Watchdog

The first two alarms trip when no legal message is sent from the serial link to the drive for a time longer than the time set in the relevant watchdog parameters; **these alarms are active only if parameters R005 or R012 are set other than zero.**



**NOTE** Alarms **A061** and **A062** do not trip if, due to the parameters in the CONTROL METHOD MENU or due to the status of the SOURCE SELECTION or LOC/REM inputs (see DIGITAL INPUTS MENU), the information sent via serial link is not currently used for the commands or the references.

The third alarm trips only if the **display/keypad used as a reference/command source** detects a communication loss for a time longer than 2 seconds.

## 51.2. List of Parameters R001 to R013

Table 120: List of parameters R001 to R013

| Parameter   | FUNCTION   | User Level  | MODBUS Address | Default Values        |
|-------------|--|-------------|----------------|-----------------------|
| <b>R001</b> | Drive MODBUS Address for Serial Link 0 (D9-pole)     | ENGINEERING | 588            | 1                     |
| <b>R002</b> | Response Delay for Serial Link 0 (D9-pole)           | ENGINEERING | 589            | 5msec                 |
| <b>R003</b> | Baud Rate for Serial Link 0 (D9-pole)                | ENGINEERING | 590            | 6:38400 bps           |
| <b>R004</b> | Time added to 4byte-time for Serial Link 0 (D9-pole) | ENGINEERING | 591            | 2msec                 |
| <b>R005</b> | Watchdog time for Serial Link 0 (D9-pole)            | ENGINEERING | 592            | 0.0sec                |
| <b>R006</b> | Parity Bit for Serial Link 0 (D9-pole)               | ENGINEERING | 593            | 1:Disabled 2 Stop-bit |
| <b>R008</b> | Drive MODBUS address for Serial Link 1 (RJ45)        | ENGINEERING | 595            | 1                     |
| <b>R009</b> | Response Delay for Serial Link 1 (RJ45)              | ENGINEERING | 596            | 5 msec                |
| <b>R010</b> | Baud Rate for Serial Link 1 (RJ45)                   | ENGINEERING | 597            | 6:38400 bps           |
| <b>R011</b> | Time Added to 4byte-time for Serial link 1 (RJ45)    | ENGINEERING | 598            | 2msec                 |
| <b>R012</b> | Watchdog Time for Serial Link 1 (RJ45)               | ENGINEERING | 599            | 0.0sec                |
| <b>R013</b> | Parity Bit for Serial Link 1 (RJ45)                  | ENGINEERING | 600            | 1:Disabled 2 Stop-bit |

### R001 Drive MODBUS Address for Serial Link 0 (D9-pole)

|             |                 |  |         |
|-------------|-----------------|--|---------|
| <b>R001</b> | <b>Range</b>    | 1 ÷ 247  | 1 ÷ 247 |
|             | <b>Default</b>  | 1  | 1       |
|             | <b>Level</b>    | ENGINEERING  |         |
|             | <b>Address</b>  | 588  |         |
|             | <b>Function</b> | This parameter determines the address assigned to the drive connected through RS485 of serial link 0 (9-pole, male D connector). |         |

### R002 Response Delay for Serial Link 0 (D9-pole)

|             |                 |  |               |
|-------------|-----------------|--|---------------|
| <b>R002</b> | <b>Range</b>    | 1 ÷ 1000   | 1 ÷ 1000 msec |
|             | <b>Default</b>  | 5  | 5 msec        |
|             | <b>Level</b>    | ENGINEERING  |               |
|             | <b>Address</b>  | 589  |               |
|             | <b>Function</b> | This parameter determines the drive response delay after a master query sent through serial link 0 (9-pole, male D connector). |               |

### R003 Baud Rate for Serial Link 0 (D9-pole)

|             |                 |  |  |
|-------------|-----------------|--|--|
| <b>R003</b> | <b>Range</b>    | 1 ÷ 7  | 1: 1200 bps<br>2: 2400 bps<br>3: 4800 bps<br>4: 9600 bps<br>5: 19200 bps<br>6: 38400 bps<br>7: 57600 bps |
|             | <b>Default</b>  | 6  | 6: 38400bps  |
|             | <b>Level</b>    | ENGINEERING  |  |
|             | <b>Address</b>  | 590  |  |
|             | <b>Function</b> | This parameter determines the baud rate, expressed in bits per second, for serial link 0 (9-pole, male D connector). |  |

**R004 Time added to 4-Byte-Time for Serial Link 0 (D9-pole)**

|             |                 |   |                |
|-------------|-----------------|---|----------------|
| <b>R004</b> | <b>Range</b>    | 1 ÷ 10000   | 1 ÷ 10000 msec |
|             | <b>Default</b>  | 2   | 2 msec         |
|             | <b>Level</b>    | ENGINEERING   |                |
|             | <b>Address</b>  | 591   |                |
|             | <b>Function</b> | This parameter determines the limit time when no character is received from serial link 0 (9-pole, male D connector) and the message sent from the master to the drive is considered as complete. |                |

**R005 Watchdog Time for Serial Link 0 (D9-pole)**

|             |                 |   |                |
|-------------|-----------------|---|----------------|
| <b>R005</b> | <b>Range</b>    | 0 ÷ 60000   | 0 ÷ 6000.0 sec |
|             | <b>Default</b>  | 0   | 0.0 sec        |
|             | <b>Level</b>    | ENGINEERING   |                |
|             | <b>Address</b>  | 592   |                |
|             | <b>Function</b> | If not set at zero, this parameter determines the time limit after which alarm <b>A061</b> WDG Serial 0 Alarm trips if the drive does not receive any legal message through serial link 0 (9-pole, male D connector). |                |

**R006 Parity Bit for Serial Link 0 (D9-pole)**

|             |                 |  |   |
|-------------|-----------------|--|---|
| <b>R006</b> | <b>Range</b>    | 0 ÷ 3  | 0: Disabled 1 Stop-bit<br>1: Disabled 2 Stop-bit<br>2: Even (1 Stop bit)<br>3: Odd (1 Stop bit) |
|             | <b>Default</b>  | 1  | 1: Disabled 2 Stop-bit  |
|             | <b>Level</b>    | ENGINEERING  |   |
|             | <b>Address</b>  | 593  |   |
|             | <b>Function</b> | This parameter determines whether the parity bit is used or not when creating the MODBUS message through serial link 0 (9-pole, male D connector). |   |

**R008 Drive MODBUS Address for Serial Link 1 (RJ45)**

|             |                 |   |         |
|-------------|-----------------|---|---------|
| <b>R008</b> | <b>Range</b>    | 1 ÷ 247   | 1 ÷ 247 |
|             | <b>Default</b>  | 1   | 1       |
|             | <b>Level</b>    | ENGINEERING   |         |
|             | <b>Address</b>  | 595   |         |
|             | <b>Function</b> | This parameter determines the address assigned to the drive connected to the network through RS485 of serial link 1 (RJ45 connector). |         |



**NOTE**

The display/keypad connected through RJ45 connector dialogues correctly with the drive using the default values preset in the parameter set for serial link 1 (RJ45).

**R009 Response Delay for Serial Link 1 (RJ45)**

|             |                 |  |               |
|-------------|-----------------|--|---------------|
| <b>R009</b> | <b>Range</b>    | 1 ÷ 1000   | 1 ÷ 1000 msec |
|             | <b>Default</b>  | 5  | 5 msec        |
|             | <b>Level</b>    | ENGINEERING  |               |
|             | <b>Address</b>  | 596  |               |
|             | <b>Function</b> | This parameter determines the drive response delay after a master query sent through serial link 1 (RJ45 connector). |               |

**R010 Baud Rate for Serial Link 1 (RJ45)**

|             |                 |  |  |
|-------------|-----------------|--|--|
| <b>R010</b> | <b>Range</b>    | 1 ÷ 7  | 1: 1200 bps<br>2: 2400 bps<br>3: 4800 bps<br>4: 9600 bps<br>5: 19200 bps<br>6: 38400 bps<br>7: 57600 bps |
|             | <b>Default</b>  | 6  | 6: 38400bps  |
|             | <b>Level</b>    | ENGINEERING  |  |
|             | <b>Address</b>  | 597  |  |
|             | <b>Function</b> | This parameter determines the baud rate, expressed in bits per second, for serial link 1 (RJ45 connector). |  |

**R011 Time Added to 4-Byte-Time for Serial Link 1 (RJ45)**

|             |                 |   |                |
|-------------|-----------------|---|----------------|
| <b>R011</b> | <b>Range</b>    | 1÷10000   | 1 ÷ 10000 msec |
|             | <b>Default</b>  | 2   | 2 msec         |
|             | <b>Level</b>    | ENGINEERING   |                |
|             | <b>Address</b>  | 598   |                |
|             | <b>Function</b> | This parameter determines the time limit when no character is received from serial link 1 (RJ45 connector) and the message sent from the master to the drive is considered as complete. |                |

**R012 Watchdog Time for Serial Link 1 (RJ45)**

|             |                 |  |                |
|-------------|-----------------|--|----------------|
| <b>R012</b> | <b>Range</b>    | 0 ÷ 60000  | 0 ÷ 6000.0 sec |
|             | <b>Default</b>  | 0  | 0.0 sec        |
|             | <b>Level</b>    | ENGINEERING  |                |
|             | <b>Address</b>  | 599  |                |
|             | <b>Function</b> | If this parameter is not set at zero, it determines the time limit after which alarm <b>A062</b> WDG Serial Link 1 Alarm trips if the drive does not receive any legal message through serial link 1 (RJ45 connector). |                |

**R013 Parity Bit for Serial Link 1 (RJ45)**

|             |                 |  |   |
|-------------|-----------------|--|---|
| <b>R013</b> | <b>Range</b>    | 0 ÷ 3  | 0: Disabled 1 Stop-bit<br>1: Disabled 2 Stop-bit<br>2: Even (1 Stop bit)<br>3: Odd (1 Stop bit) |
|             | <b>Default</b>  | 1  | 1: Disabled 2 Stop-bit  |
|             | <b>Level</b>    | ENGINEERING  |   |
|             | <b>Address</b>  | 600  |   |
|             | <b>Function</b> | This parameter determines whether the parity bit is used or not when creating the MODBUS message through serial link 1 (RJ45 connector). |   |

## 52. FIELDBUS CONFIGURATION MENU

### 52.1. Overview



**NOTE** See the OPTIONAL BOARDS FOR FIELDBUS section in the Sinus Penta's Installation Guide for the description of the optional board required.



**NOTE** The parameters included in this menu are **Rxxx** parameters. Once saved, they are active only when the drive is next switched on or when the control board is reset (by holding down the **RESET** key for more than 5 secs).



**CAUTION**

This menu is not applicable to ES919 communications boards (see relevant section in the Sinus Penta's Installation Guide). ES919 boards act as gateways and change the **MODBUS** RS485 packets into the packets of each protocol being used.

The exchanged parameters are all the **Mxxx** measures from the Sinus Penta to the Master and all the **Ixxx** inputs from the Master to the Sinus Penta (as detailed in the MEASURES MENU, Table 88: Remote command inputs from serial link and Table 89: Reference inputs from serial link)

#### 52.1.1. ALARM A070 (COMMUNICATION SUSPENDED)

Alarm **A070** trips if the Sinus Penta is not sent any legal message via FIELDBUS within the timeout set in parameter **R016**. Set parameter **R016** to 0 to disable alarm **A070**.

A legal message is the word of the digital inputs (**M035**) with bit 15=1 written by the master.

Important: this is enabled only when the drive receives the first message with bit 15=1.

To reset alarm **A070**, force communication between the Master and the Penta drive with bit 15 of the digital input word always set to 1 and reset the drive control board. If communications between the Master and the Slave (Penta) cannot be restored, alarm **A070** is reset after setting parameter **R016** to zero and after resetting the Penta drive. When the drive is next powered on, resetting the alarm reset will affect the drive control board.



**NOTE**

Alarm **A070** does not trip if, due to the parameters in the CONTROL METHOD MENU or due to the status of the SOURCE SELECTION or LOC/REM inputs (see DIGITAL INPUTS MENU), the information sent via serial link is not currently used for the commands or the references.

### 52.2. List of Parameters R016 to R017

Table 121: List of parameters R016 to R017

| Parameter   | FUNCTION                                  | User Level  | MODBUS Address | Default Values |
|-------------|---|-------------|----------------|----------------|
| <b>R016</b> | Fieldbus Watchdog Time                    | ENGINEERING | 603            | 0 ms           |
| <b>R017</b> | Analog Outputs controlled by the Fieldbus | ENGINEERING | 604            | 000b           |

#### R016 Fieldbus Watchdog Time

| R016 | Range    | 0 ÷ 60000  | 0 ÷ 60000 ms |
|------|----------|--|--------------|
|      | Default  | 0  | 0 ms         |
|      | Level    | ENGINEERING  |              |
|      | Address  | 603  |              |
|      | Function | If not set at zero, this parameter determines the time limit after which <b>A070</b> Fieldbus WDG trips (no legal writing is received from the fieldbus in a given time interval). |              |



**NOTE**

The Watchdog activates only once the drive has received the first legal message from the master, as described in Alarm A070 (Communication Suspended). This avoids untimely activation due to different start times between the master and the drive.

**R017 Analog Outputs Controlled by the Fieldbus**

|             |                 |  |   |
|-------------|-----------------|--|---|
| <b>R017</b> | <b>Range</b>    | 000b ÷ 111b binary<br>0000h ÷ 0007h hex<br>0 ÷ 7 decimal   | 000b → None<br>001b → AO1<br>010b → AO2<br>100b → AO3 |
|             | <b>Default</b>  | 000b   | 000b → None   |
|             | <b>Level</b>    | ENGINEERING  |   |
|             | <b>Address</b>  | 604  |   |
|             | <b>Function</b> | To select analog outputs controlled by the fieldbus, select the bit corresponding to the analog output to be controlled.<br>Example:<br><b>R017</b> = 0011b = 3 decimal → analog outputs AO1 and AO2 are controlled directly by the fieldbus, <b>irrespective of their configuration in the ANALOG AND FREQUENCY OUTPUTS MENU.</b> |   |

## 52.3. Exchanged Parameters

The tables below state the Sinus Penta parameters exchanged via Fieldbus.

Each table contains:

- 1) the parameter code;
- 2) its description;
- 3) its range;
- 4) its unit of measure (also indicated on the display);
- 5) the ratio between the Sinus Penta value (exchanged via Fieldbus) and the represented hardware value (as displayed).

**N.B.:** Each parameter is exchanged as an integer number with a 16-bit sign (from -32768 to +32767).



**NOTE** Each parameter is exchanged as an integer value with 16-bit sign (-32768 to +32767).



**NOTE** Bytes are exchanged in **big-endian mode** (the most significant value is stored to the smallest memory address).  
When using an Intel based master/PLC chipset, then the data below will be byte-swapped.

### 52.3.1. FROM THE MASTER TO THE SINUS PENTA

| Word | 1) Code | 2) Description  | 3) Range          | 4) Unit of Measure | 5) Scaling |
|------|---------|---|-------------------|--------------------|------------|
| 1    | M042    | Speed reference/limit from FIELDBUS (integer portion) | - 32000 ÷ + 32000 | rpm                | 1          |
| 2    | M043    | Speed reference/limit from FIELDBUS (decimal portion) | - 99 ÷ + 99       | rpm                | x 100      |
| 3    | M045    | Torque reference/limit from FIELDBUS                  | - 5000 ÷ + 5000   | %                  | x 10       |
| 4    | M047    | PID reference from FIELDBUS                           | - 10000 ÷ + 10000 | %                  | x 100      |
| 5    | M035    | Digital Inputs from FIELDBUS                          | -                 | -                  | -          |
| 6    |         | Command for Digital Outputs from FIELDBUS             | -                 | -                  | -          |
| 7    | AO1     | Analog Output 1 controlled by FIELDBUS                | + 111 ÷ + 1889    | -                  | -          |
| 8    | AO2     | Analog Output 2 controlled by FIELDBUS                | + 111 ÷ + 1889    | -                  | -          |
| 9    | AO3     | Analog Output 3 controlled by FIELDBUS                | + 111 ÷ + 1889    | -                  | -          |
| 10   | M049    | PID Feedback from FIELDBUS                            | - 10000 ÷ + 10000 | -                  | x 100      |

The parameter exchange memory zone may also be used to read and write all the Penta drive's parameters by referring to their Modbus address.

| Word | 1) Number     | 2) Description                                    | 3) Range                    | 4) Unit of measure | 5) Ratio |
|------|---------------|---|-----------------------------|--------------------|----------|
| 11   | Type of cycle | Read or write cycle                               | Allowable values 0x80, 0x40 | -                  | 1        |
| 12   | Address       | Modbus address of the variable to be read/written | 0 ÷ 8191                    | -                  | 1        |
| 13   | Value         | Value to be written to the Modbus address         | -32768 ÷ +32767             | -                  | 1        |

**Word 1: Speed reference/limit from FIELDBUS (integer portion)**

Word 1 of the memory map details the integer portion of the speed reference (**M042**) in either IFD, VTC or FOC mode.

|                                 |            |
|---------------------------------|------------|
| bit [15..8]                     | bit [7..0] |
| Speed reference integer portion |            |

The speed reference from the FIELDBUS is obtained by adding the decimal portion to the integer portion (see Word 2).

This value is included in the global speed reference of the drive (measure **M000**) along with the other reference sources if at least one of parameters **C143** to **C146** is set as 6:FieldBus.

The speed limit from FIELDBUS is significant if parameter **C147** is set as 6:FieldBus and the type of reference of the active motor (parameters **C011** / **C054** / **C097**) is set as 2:Torque with Speed Limit.

**Word 2: Speed reference/limit from FIELDBUS (decimal portion)**

Word 2 details the decimal portion of the speed reference (**M043**) ONLY IN FOC MODE. The value sent by the Master to the Sinus Penta as the decimal portion of the speed reference must be multiplied by 100.

In order to send a speed reference of XXX.50rpm, the low byte of the word must contain the value  $50_{10}$  or  $00110010_2$  ( $0.50_{10} \times 100 = 50_{10}$ ).

Example: **M042**=210; **M043**=50  $\Rightarrow$  speed ref. = 210.50 rpm

|                                 |            |
|---------------------------------|------------|
| bit [15..8]                     | bit [7..0] |
| Speed reference decimal portion |            |

**Word 3: Torque reference/limit from FIELDBUS**

The torque reference from the FIELDBUS (**M045**) is significant if at least one of parameters **C143** to **C146** is set as 6:FieldBus and if the type of reference of the active motor (parameters **C011/C054/C097**) is set as 1:Torque or as 2:Torque with Speed Limit, or if the drive is in slave mode from digital input.

The torque limit from the FIELDBUS is significant if parameter **C147** is set as 6:FieldBus.

The value sent by the Master to the Sinus Penta as the torque reference/torque limit must be multiplied by 10. In order to send a torque reference/torque limit of 50%, the word must contain the value  $500_{10}$  or  $111110100_2$  ( $50\%_{10} \times 10 = 500_{10}$ ).

|                        |            |
|------------------------|------------|
| bit [15..8]            | bit [7..0] |
| Torque reference/limit |            |

**Word 4: PID reference from FIELDBUS**

The PID reference (**M047**) can be sent from the fieldbus if at least one of the parameters **C285** to **C287** is set as 6:Fieldbus.

The value sent by the Master to the Sinus Penta as the PID reference must be multiplied by 100.

E.g. In order to send a PID reference of 50%, the word must contain the value  $5000_{10}$  or  $111110100_2$  ( $50\%_{10} \times 100 = 5000_{10}$ ).

|                             |            |
|-----------------------------|------------|
| bit [15..8]                 | bit [7..0] |
| PID reference from FIELDBUS |            |

**Word 5: Digital Inputs from FIELDBUS**

The virtual digital inputs via the Fieldbus are the low byte of the word:

| bit 15 | bit [14..8] | bit [7..0] |      |      |      |      |              |      |      |
|--------|-------------|------------|------|------|------|------|--------------|------|------|
| 1      |             | MDI8       | MDI7 | MDI6 | MDI5 | MDI4 | MDI3 (RESET) | MDI2 | MDI1 |

The logic status of these bits is included in the overall status of the drive digital inputs (measure **M031**) along with the other command sources if at least one of the parameters **C140 ÷ C142** is set as 6:FieldBus.



**NOTE** Auxiliary virtual terminal board XMD1.. 8 cannot be simulated via fieldbus.



**CAUTION** Bit 15 must always be written =1; this means that data exchanged between the master and the drive is consistent, thus keeping the watchdog counter reset (see Alarm A070 (Communication Suspended)).

**Word 6: Command for Digital Outputs from FIELDBUS**

Digital commands from FIELDBUS are the 4 lower bytes of the word:

| bit [15...4] | bit [3..0] |       |       |       |
|--------------|------------|-------|-------|-------|
|              | CMD 4      | CMD 3 | CMD 2 | CMD 1 |

Byte format:

| Bit | Command    | Position in the selection vector |
|-----|------------|----------------------------------|
| 0   | Fbus CMD 1 | D34                              |
| 1   | Fbus CMD 2 | D35                              |
| 2   | Fbus CMD 3 | D36                              |
| 3   | Fbus CMD 4 | D37                              |

Columns 2 and 3 state the name and position of the commands sent via fieldbus.

Example: to control digital output 1 via fieldbus through command 4, set the parameters below in the DIGITAL OUTPUTS MENU:

- P270** = 1: Digital            Digital Output Mode
- P271** = D37: Fbus CMD4   Variable A Selection
- P278** = 1: True            Output Logic Level

**Words 7, 8, 9: Analog Outputs controlled by FIELDBUS**

Parameter **R017** needs to be properly set up to distinguish which Analog Outputs are to be controlled by the Fieldbus.

Byte format:

| Bit | Analog Output controlled by the fieldbus |
|-----|--|
| 0   | AO1                                      |
| 1   | AO2                                      |
| 2   | AO3                                      |

Example: **R017** = 011<sub>2</sub> = 3<sub>10</sub> → analog outputs AO1 and AO2 are controlled directly by the fieldbus, independently of their configuration in the ANALOG AND FREQUENCY OUTPUTS MENU.

The correspondence between the exchanged value and the real value (in volts) of the analog outputs is as follows:

| Exchanged value | Voltage (V) | Current (mA) |
|-----------------|-------------|--------------|
| + 1889          | + 10        | + 20 mA      |
| + 1000          | 0           | 0            |
| + 111           | - 10        | - 20 mA      |

#### Word 10: PID feedback from FIELDBUS

The PID feedback (**M049**) can be sent from the fieldbus if at least one of the parameters **C288** to **C290** is set as 6:Fieldbus.

The value sent by the Master to the Sinus Penta as the PID feedback must be multiplied by 100.

E.g. In order to send a PID feedback of 50%, the word must contain the value  $5000_{10}$  or  $111110100_2$  ( $50\%_{10} \times 100 = 5000_{10}$ ).

| bit [15..8]                | bit [7..0] |
|----------------------------|------------|
| PID feedback from FIELDBUS |            |

#### Word 11: Type of cycle required

The word states the cycle required:

0x40: Write cycle

0x80: Read cycle

For the "Read cycle", the field including the read address (Word 12) is to be completed beforehand.

For the "Write cycle", the field including the write address (Word 12) as well as the field including the value to be written (Word 13) are to be completed beforehand.



#### NOTE

At the end of each read/write cycle or between any two cycles, enter value "0x00" in Word 11.

#### Word 12: Modbus address of the variable to read/write

Includes the Modbus address of the variable to be read (read cycle) or written (write cycle).



#### NOTE

In order to save a parameter to non-volatile memory, see [1009 Parameter save](#).

#### Word 13: Value to be written

Only in case of write cycles, it includes the value to be written to the address required.

### 52.3.2. FROM THE SINUS PENTA TO THE MASTER

| Word | 1) Code     | 2) Description   | 3) Range          | 4) Unit of Measure   | 5) Scaling           |
|------|-------------|--|-------------------|----------------------|----------------------|
| 1    |             | Status + Alarms  | –                 | –                    | –                    |
| 2    | <b>M026</b> | Output Current   | 0 ÷ 65000         | A                    | x 10                 |
| 3    | <b>M004</b> | Motor Speed  | – 32000 ÷ + 32000 | rpm                  | x 1                  |
| 4    |             | Third measure that may be configured with <b>P330</b>  | All the measures  | See selected measure | See selected measure |
| 5    |             | Fourth measure that may be configured with <b>P331</b> | All the measures  | See selected measure | See selected measure |
| 6    | <b>DIN</b>  | Digital Inputs   | –                 | –                    | –                    |
| 7    | <b>DOU</b>  | Digital Outputs  | –                 | –                    | –                    |
| 8    | <b>REF</b>  | REF Analog Input                                       | – 16380 ÷ + 16380 | –                    | –                    |
| 9    | <b>AIN1</b> | AIN1 Analog Input                                      | – 16380 ÷ + 16380 | –                    | –                    |
| 10   | <b>AIN2</b> | AIN2 Analog Input                                      | – 16380 ÷ + 16380 | –                    | –                    |

The words below are significant only when using the parameter exchange memory zone to read and write all the Penta drive's parameters by referring to their Modbus address.

| Word | 1) Code                                   | 2) Description                     | 3) Range        | 4) Unit of Measure | 5) Scaling |
|------|---|------------------------------------|-----------------|--------------------|------------|
| 11   | <b>Return value of the cycle required</b> | Return value of the cycle required | –               | –                  | 1          |
| 12   | <b>Read value</b>                         | Read value                         | –32768 ÷ +32767 | –                  | 1          |

#### Word 1: Status + Alarms

The **Status** and **Alarms** are displayed over the fieldbus in the following format:

|             |            |
|-------------|------------|
| bit [15..8] | bit [7..0] |
| Status      | Alarms     |

The **Status** codes are given in Table 131

The **Alarm** codes are given in Table 128.

#### Word 2: Output Current

The output current measure (**M026**) is displayed as a value that must be divided by 10 to obtain the actual motor current.

As a result, if the returned value from the Sinus Penta to the Master is 100, then the actual output motor current is 10A.

|                |            |
|----------------|------------|
| bit [15..8]    | bit [7..0] |
| Output Current |            |

#### Word 3: Motor Speed

The output motor speed (**M004**) is displayed as follows:

|             |            |
|-------------|------------|
| bit [15..8] | bit [7..0] |
| Motor Speed |            |

**Words 4 & 5: Third & Fourth measure that may be configured with P330 & P331**

Words 4 & 5 may be configured with **P330** and **P331** – more details are given in the **FIELD BUS PARAMETERS MENU**. Both words 4 & 5 are represented as follows:

|  |            |
|--|------------|
| bit [15..8]  | bit [7..0] |
| <b>Mxxx</b> represented by <b>P330</b> and <b>P331</b> |            |

**Word 6: Digital Inputs**

Digital input status in the word:

|             |       |       |       |       |       |       |       |            |      |      |      |      |                 |      |      |
|-------------|-------|-------|-------|-------|-------|-------|-------|------------|------|------|------|------|-----------------|------|------|
| bit [15..8] |       |       |       |       |       |       |       | bit [7..0] |      |      |      |      |                 |      |      |
| XMD18       | XMD17 | XMD16 | XMD15 | XMD14 | XMD13 | XMD12 | XMD11 | MD18       | MD17 | MD16 | MD15 | MD14 | MDI3<br>(RESET) | MDI2 | MD11 |

**Word 7: Digital Outputs**

Digital output status in the word:

|              |             |       |       |       |       |       |       |       |            |            |      |      |               |
|--------------|-------------|-------|-------|-------|-------|-------|-------|-------|------------|------------|------|------|---------------|
| bit [15..14] | bit [13..8] |       |       |       |       |       | bit 7 | bit 6 | bit [5..4] | bit [3..0] |      |      |               |
|              | XMDO6       | XMDO5 | XMDO4 | XMDO3 | XMDO2 | XMDO1 |       | [*]   |            | MDO4       | MDO3 | MDO2 | MDO1/<br>FOUT |

[\*] Status of the Pre-charge contactor

**Words 8, 9, 10: REF, AIN1, AIN2 Analogue Signal**

Full scale value  $\pm 16380$  is a rated value corresponding to an input range of  $\pm 10V$  10V (for 4..20mA input, the full-scale value is 1310 - 6652). This value can be changed due to automatic compensation of the tolerance of the input stage.

|                   |            |
|-------------------|------------|
| bit [15..8]       | bit [7..0] |
| REF / AIN1 / AIN2 |            |



**NOTE**

The measures of the analog inputs sent from the Sinus Penta to the Master are the unfiltered measure values detected in the A/D converter output. For filtered measures, use **M037**, **M038** and **M039** respectively.

**Word 11: Return value of the cycle required**

The word includes the return value of the cycle required (bits):

|             |                 |                 |
|-------------|-----------------|-----------------|
| bit [15..8] | bit 7           | bit [6..0]      |
|             | 1= active cycle | See table below |

|   |                       |
|---|-----------------------|
| 0 | NO ANSWER             |
| 1 | WAITING               |
| 2 | ANSWER OK             |
| 3 | ILLEGAL DATA VALUE    |
| 4 | ILLEGAL ADDRESS VALUE |
| 5 | CONTROL IS ON         |
| 6 | WRONG ACCESS LEVEL    |
| 7 | MMI IS PROGRAMMING    |

**Word 12: Read value**

The word includes the value read in case of Read cycle.

This value is to considered as legal when Word 11= 0x82 (active cycle + ANSWER OK).

## 53. EXPANSION BOARD CONFIGURATION MENU

### 53.1. Overview



**NOTE** Parameters in this menu are **Rxxx** parameters. Once saved, they are active only when the drive is next switched on or when the control board is reset (by holding down the **RESET** key for more than 5 secs).

### 53.2. List of Parameters R021 to R023

Table 122: List of parameters R021 to R023

| Parameter | FUNCTION            | User Level  | MODBUS Address | DEFAULT VALUES |
|-----------|---------------------|-------------|----------------|----------------|
| R021      | Data Logger setting | ENGINEERING | 551            | Disable        |
| R023      | I/O board setting   | ENGINEERING | 553            | None           |

#### R021 Data Logger Setting

|             |                 |   |                         |
|-------------|-----------------|---|-------------------------|
| <b>R021</b> | <b>Range</b>    | 1 ÷ 2   | 1: Disable<br>2: Enable |
|             | <b>Default</b>  | 1   | 1: Disable              |
|             | <b>Level</b>    | ENGINEERING   |                         |
|             | <b>Address</b>  | 551   |                         |
|             | <b>Function</b> | This parameter enables or disables Data Logger initialization (if the Data Logger board is fitted). |                         |

#### R023 I/O Board Setting

|             |                 |   |   |
|-------------|-----------------|---|---|
| <b>R023</b> | <b>Range</b>    | 0 ÷ 4   | 0: None<br>1: XMDI/O<br>2: XMDI/O + XAIN<br>3: XMDI/O + PT100<br>4: XMDI/O + XAIN + PT100 |
|             | <b>Default</b>  | 0   | 0: None   |
|             | <b>Level</b>    | ENGINEERING   |   |
|             | <b>Address</b>  | 553   |   |
|             | <b>Function</b> | Based on the settings in the relevant parameter, this parameter enables controlling digital I/O (XMDI/O), analog inputs (XAIN) and PT100 probes located on optional control boards. |   |



**NOTE** ES847 is required to control analog inputs (XAIN) and PT100 probes. Either ES847 or ES870 can be used to control digital I/O (XMDI/O).

## 54. PROFIDRIVE BOARD CONFIGURATION MENU

### 54.1. Overview

This menu allows programming the PROFIdrive expansion board. It can be viewed only if the PROFIdrive board is connected to the control board.

**NOTE**

Parameters in this menu are **Rxxx** parameters.

Once changed and saved, they become active only when the drive is next switched on or when its control board is reset by holding down the **RESET** key for more than 5 secs.

**NOTE**

For the correct operation of the PROFIdrive board, please refer to the Sinus Penta's Installation Guide and to the PROFIdrive COMMUNICATIONS BOARD – Installation and Programming Guide.

**NOTE**

If the PROFIdrive option is present, parameter **C149 START Input** must be assigned to value 1: MDI1.

### 54.2. List of Parameters R025 to R045

Table 123: List of parameters R025 to R045

| Parameter   | FUNCTION                         | User Level  | MODBUS Address | DEFAULT VALUES       |
|-------------|----------------------------------|-------------|----------------|----------------------|
| <b>R025</b> | Slave address                    | ENGINEERING | 547            | 1                    |
| <b>R026</b> | PZD3 OUT                         | ENGINEERING | 548            | 1: DIGITAL INPUTS    |
| <b>R027</b> | PZD4 OUT                         | ENGINEERING | 549            | 0: NOT USED          |
| <b>R028</b> | PZD5 OUT                         | ENGINEERING | 550            | 0: NOT USED          |
| <b>R029</b> | PZD6 OUT                         | ENGINEERING | 554            | 0: NOT USED          |
| <b>R030</b> | PZD7 OUT                         | ENGINEERING | 555            | 0: NOT USED          |
| <b>R031</b> | PZD8 OUT                         | ENGINEERING | 556            | 0: NOT USED          |
| <b>R032</b> | PZD9 OUT                         | ENGINEERING | 557            | 0: NOT USED          |
| <b>R033</b> | PZD10 OUT                        | ENGINEERING | 558            | 0: NOT USED          |
| <b>R034</b> | PZD3 IN                          | ENGINEERING | 559            | 0: NOT USED          |
| <b>R035</b> | PZD4 IN                          | ENGINEERING | 581            | 0: NOT USED          |
| <b>R036</b> | PZD5 IN                          | ENGINEERING | 582            | 0: NOT USED          |
| <b>R037</b> | PZD6 IN                          | ENGINEERING | 583            | 0: NOT USED          |
| <b>R038</b> | PZD7 IN                          | ENGINEERING | 584            | 0: NOT USED          |
| <b>R039</b> | PZD8 IN                          | ENGINEERING | 585            | 0: NOT USED          |
| <b>R040</b> | PZD9 IN                          | ENGINEERING | 586            | 0: NOT USED          |
| <b>R041</b> | PZD10 IN                         | ENGINEERING | 587            | 0: NOT USED          |
| <b>R044</b> | Drive Profile Communication Mode | ENGINEERING | 520            | 0: DP V0             |
| <b>R045</b> | Drive Profile Selection          | ENGINEERING | 521            | 1: VENDOR SPECIFIC 1 |

**R025 SLAVE ADDRESS**

|             |                 |   |         |
|-------------|-----------------|---|---------|
| <b>R025</b> | <b>Range</b>    | 0 ÷ 126   | 0 ÷ 126 |
|             | <b>Default</b>  | 1   | 1       |
|             | <b>Level</b>    | ENGINEERING   |         |
|             | <b>Address</b>  | 547   |         |
|             | <b>Function</b> | This parameter sets the address for the PROFIdrive board. |         |



**NOTE**

The programmed value has effect only if the board address selectors are set to zero (see the Sinus Penta's Installation Installation Guide and the **PROFIdrive comms board User Manual**).

**R026 to R033 PZD3(/10) OUT**

|             |                 |  |   |
|-------------|-----------------|--|---|
| <b>R026</b> | <b>Range</b>    | 0 ÷ 6  | 0: NOT USED<br>1: DIGITAL INPUTS<br>2: AUXILIARY DIGITAL INPUTS (I/O expansion board)<br>3: DIGITAL OUTPUT COMMANDS<br>4: TORQUE REFERENCE<br>5: PID REFERENCE<br>6: PID FEEDBACK |
|             | <b>Default</b>  | 1  | 1: DIGITAL INPUTS   |
|             | <b>Level</b>    | ENGINEERING  |   |
|             | <b>Address</b>  | 548 ÷ 550 // 554 ÷ 558   |   |
|             | <b>Function</b> | These parameters allow selecting the inputs to be downloaded from the Master PLC to the drive through the eight process data items that can be mapped in the fast communication area between the Master and the Slave station. |   |

**R034 ÷ R041 PZD3(/10) IN**

|             |                 |   |             |
|-------------|-----------------|---|-------------|
| <b>R034</b> | <b>Range</b>    | 0 ÷ 91  | 0 ÷ 91      |
|             | <b>Default</b>  | 0   | 0: NOT USED |
|             | <b>Level</b>    | ENGINEERING   |             |
|             | <b>Address</b>  | 559 // 581 ÷ 587  |             |
|             | <b>Function</b> | These parameters allow selecting the measures to be passed to the drive from the Master PLC through the eight process data items that can be mapped in the fast communication area between the Master and the Slave station. You can select any measure from the MEASURES MENU. |             |

**R044 DRIVE PROFILE COMMUNICATION MODE**

|             |                 |   |                      |
|-------------|-----------------|---|----------------------|
| <b>R044</b> | <b>Range</b>    | 0 ÷ 1   | 0: DP V0<br>1: DP V1 |
|             | <b>Default</b>  | 0   | 0: DP V0             |
|             | <b>Level</b>    | ENGINEERING   |                      |
|             | <b>Address</b>  | 520   |                      |
|             | <b>Function</b> | This parameter sets the version of the PROFIdrive protocol. |                      |

**R045 DRIVE PROFILE SELECTION**

|             |                          |  |   |   |
|-------------|--------------------------|--|---|---|
| <b>R045</b> | <b>Range</b>             | 0 ÷ 2  | 0: PROFIDRIVE<br>1: VENDOR SPECIFIC 1<br>2: VENDOR SPECIFIC 2 |   |
|             | <b>Default</b>           | 1  | 1: VENDOR SPECIFIC 1  |   |
|             | <b>Level</b>             | ENGINEERING  |   |   |
|             | <b>Address</b>           | 507  |   |   |
|             | <b>Function</b>          | This parameter sets the control mode (Command and Reference) for the Slave station.<br>0: PROFIDRIVE<br>1: VENDOR SPECIFIC 1<br>2: VENDOR SPECIFIC 2 |   |   |
|             |                          |  | <b>Command</b>  | <b>Reference</b>                              |
|             | <b>PROFIDRIVE</b>        | According to the PROFIdrive protocol.  | According to the PROFIdrive protocol.                         | According to the PROFIdrive protocol.         |
|             | <b>VENDOR SPECIFIC 1</b> | According to the PROFIdrive protocol.  | One-to-one scale of the programmed reference.                 | One-to-one scale of the programmed reference. |
|             | <b>VENDOR SPECIFIC 2</b> | The eight low bits in the CONTROL WORD represent the eight digital inputs in the control board.  | One-to-one scale of the programmed reference.                 | One-to-one scale of the programmed reference. |



**NOTE**

Bit 11 in the control board enables or not the Fieldbus line watchdog in any of the three control modes above, provided that parameter **R016** is set higher than zero.



**NOTE**

The watchdog activates only after the drive has received the first legal message sent from the master (see Alarm A070 (Communication Suspended), thus preventing alarm **A070** from tripping due to different power-on times between the master station and the Penta drive.

## 55. DAYLIGHT SAVING TIME

### 55.1. Overview



**NOTE**

The Daylight Saving Time menu may be accessed only if the Data Logger board is installed (even the ES851 RTC version only) and if parameter **R021** Data Logger setting is set to 2: ENABLE.

Parameters **R050** to **R053** set the DST rules for the Clock/Calendar of the Data Logger or the ES851 RTC. See DATE AND TIME MENU.



**NOTE**

By setting parameters **R050** and **R052** to 0, the DST is not managed.

### 55.2. List of Parameters R050 to R053

Table 124: List of Parameters R050 to R053

| Parameter   | FUNCTION       | User Level  | DEFAULT VALUES | MODBUS Address |
|-------------|----------------|-------------|----------------|----------------|
| <b>R050</b> | DST Start WDMM | ENGINEERING | 5703           | 524            |
| <b>R051</b> | DST Start HHMM | ENGINEERING | 200            | 525            |
| <b>R052</b> | DST End WDMM   | ENGINEERING | 5710           | 526            |
| <b>R053</b> | DST End HHMM   | ENGINEERING | 200            | 527            |

#### R050 DST Start WDMM – Week/Day/Month

| R050 | Range    | 0 ÷ 9112   | 0 ÷ 9112 |
|------|----------|--|----------|
|      | Default  | 5703   | 5703     |
|      | Level    | ENGINEERING  |          |
|      | Active   | This parameter can be viewed and changed only if the Data Logger ES851 is installed and activated ( <b>R021</b> = ENABLE).   |          |
|      | Address  | 524  |          |
|      | Function | <p><b>If the first digit of the parameter is lower than 6:</b><br/>                     The first digit (W) indicates the week of the month when the DST starts (1 = first week, 2 = second week, 3 = third week, 4 = fourth week, 5 = last week).<br/>                     The second digit (D) indicates the day of the week (1 = Monday, 7 = Sunday).<br/>                     The third and fourth digits (MM) indicate the start month (01 = January, 12 = December).<br/>                     Example:<br/>                     European Union: 5703 (last Sunday in March)<br/>                     USA: 2703 (second Sunday in March)<br/>                     Brazil: 3710 (third Sunday in October)</p> <p><b>If the first digit of the parameter is higher than or equal to 6:</b><br/>                     The first two digits (WD) correspond to the day of the month when the DST starts, added to 60 (61 corresponds to 1, 91 corresponds to 31).<br/>                     The third and fourth digit (MM) indicate the start month (01 corresponds to January, 12 corresponds to December).<br/>                     Example:<br/>                     7504 = 15 April.</p> |          |

**R051 DST Start HHMM – Hour/Minutes**

|             |                 |   |            |
|-------------|-----------------|---|------------|
| <b>R051</b> | <b>Range</b>    | 100 ÷ 2400  | 100 ÷ 2400 |
|             | <b>Default</b>  | 200   | 200        |
|             | <b>Level</b>    | ENGINEERING   |            |
|             | <b>Active</b>   | This parameter can be viewed and changed only if the Data Logger ES851 is installed and activated ( <b>R021</b> = ENABLE).  |            |
|             | <b>Address</b>  | 525   |            |
|             | <b>Function</b> | The first digit or the first two digits (if the total digits are 3 or 4 respectively) correspond to the start hours. The last two digits correspond to the minutes.<br>Example:<br>200 = 2h 00m<br>2400 = 0h 0m (midnight between the day set in <b>R050</b> and the previous day.) |            |

**R052 DST End WDMM – Week/Day/Month**

|             |                 |   |          |
|-------------|-----------------|---|----------|
| <b>R052</b> | <b>Range</b>    | 0 ÷ 9112  | 0 ÷ 9112 |
|             | <b>Default</b>  | 5710  | 5710     |
|             | <b>Level</b>    | ENGINEERING   |          |
|             | <b>Active</b>   | This parameter can be viewed and changed only if the Data Logger ES851 is installed and activated ( <b>R021</b> = ENABLE).  |          |
|             | <b>Address</b>  | 526   |          |
|             | <b>Function</b> | <p><b>If the first digit of the parameter is lower than 6:</b><br/>The first digit (W) indicates the week of the month when the DST ends (1 = first week, 2 = second week, 3 = third week, 4 = fourth week, 5 = last week). The second digit (D) indicates the day of the week (1 = Monday, 7 = Sunday). The third and fourth digits (MM) indicate the start month (01 = January, 12 = December).<br/>Example:<br/>European Union: 5710 (last Sunday in October)<br/>USA: 1711 (first Sunday in November)<br/>Brazil: 3702 (third Sunday in February)</p> <p><b>If the first digit of the parameter is higher than or equal to 6:</b><br/>The first two digits (WD) correspond to the day of the month when the DST starts, added to 60 (61 corresponds to 1, 91 corresponds to 31). The third and fourth digit (MM) indicate the start month (01 corresponds to January, 12 corresponds to December).<br/>Example:<br/>6110 = 1 October.</p> |          |

**R053 DST End HHMM – Hour/Minutes**

|             |                 |   |            |
|-------------|-----------------|---|------------|
| <b>R053</b> | <b>Range</b>    | 100 ÷ 2400  | 100 ÷ 2400 |
|             | <b>Default</b>  | 200   | 200        |
|             | <b>Level</b>    | ENGINEERING   |            |
|             | <b>Active</b>   | This parameter can be viewed and changed only if the Data Logger ES851 is installed and activated ( <b>R021</b> = ENABLE).  |            |
|             | <b>Address</b>  | 527   |            |
|             | <b>Function</b> | The first digit or the first two digits (if the total digits are 3 or 4 respectively) correspond to the end hours. The last two digits correspond to the minutes.<br>Example:<br>200 = 2h 00m<br>2400 = 0h 0m (midnight between the day set in <b>R052</b> and the previous day.) |            |

## 56. DATA LOGGER MENU

### 56.1. Overview

The Data Logger menu is to be used if the Penta drive cannot dialog with the Data Logger ES851 board through the RemoteDrive software.

Parameter **R116** imposes to ES851 the type of connection required for the communication mode being used.



**NOTE**

The Data Logger menu may be accessed only if the Data Logger board is installed and if parameter **R021** Data Logger setting is set to 2: ENABLE.

Important: The complete version of the Data Logger ES851 shall be installed (the RTC version only is not suitable for this functionality). Please refer to the Installation Guide.

The parameters described in this menu are **Rxxx** parameters.



**NOTE**

Once changed and saved, they become active only when the drive is next switched on or when the control board is reset (by holding down the **RESET** key for more than 5 secs).



**CAUTION**

The parameters set from this menu are not saved to non-volatile memory of the Data Logger board.

They must be confirmed and saved using the RemoteDrive software.

### 56.2. List of Parameters R115 and R116

Table 125: List of parameters R115 and R116

| Parameter   | FUNCTION                 | User Level  | MODBUS Address | DEFAULT VALUES      |
|-------------|--------------------------|-------------|----------------|---------------------|
| <b>R115</b> | SIM Card PIN             | BASIC       | 563            | "0000"              |
| <b>R116</b> | Preset connection status | ENGINEERING | 134            | 0: no active preset |

#### R115 SIM Card PIN

| R115 | Range    | 0x0000 ÷ 0xAAAA   | "0" ÷ "9999" |
|------|----------|---|--------------|
|      | Default  | 0x0000  | "0000"       |
|      | Level    | BASIC   |              |
|      | Address  | 563   |              |
|      | Function | This parameter indicates the digits of the PIN of the SIM card fitted in the GSM/GPRS modem.<br>The digits must be aligned left; the # symbol, which is codified as 0xA (hex) is intended as the number terminator. |              |



**NOTE**

Max. 4 digits are allowed for the SIM card PIN.

The PIN can be composed of less than 4 digits and the # symbol can be used as the PIN terminator.

#### R116 Preset Connection Status (Line 2)

| R116 Line 2 | Range    | 0 ÷ 20   | See Table 126 |
|-------------|----------|--|---------------|
|             | Address  | 1337   |               |
|             | Function | This parameter indicates if preset configurations are actually set up for the types of connections supported by ES851. |               |

**R116 Preset Connections (Line 4)**

|                        |                 |   |                     |
|------------------------|-----------------|---|---------------------|
| <b>R116<br/>Line 4</b> | <b>Range</b>    | 0 ÷ 20  | See Table 126       |
|                        | <b>Default</b>  | 0   | 0: no active preset |
|                        | <b>Level</b>    | ENGINEERING   |                     |
|                        | <b>Address</b>  | 134   |                     |
|                        | <b>Function</b> | This parameter allows forcing one of the available connecting modes to the Data Logger ES851 board. The parameters used for Ethernet connections and modem connections are the ones stored in the Penta drive.<br>Configurations 19 and 20 support both dial in and dial out. |                     |



**NOTE**

After imposing any of the preset values given in Table 126, the Data Logger is forced to Interlocked mode (see the Data Logger Measures Menu).

**Table 126: Preset connections**

| Value | COM                   | Baudrate [bps] | Stop bit | Parity | Delay [ms] |
|-------|-----------------------|----------------|----------|--------|------------|
| 0     | No active presetting  |                |          |        |            |
| 1     | Ethernet enabled      |                |          |        |            |
| 2     | PPP null modem        |                |          |        |            |
| 3     | 1(RS232)              | 38400          | 2        | no     | 2          |
| 4     | 1(RS232)              | 38400          | 1        | no     | 2          |
| 5     | 1(RS232)              | 38400          | 2        | no     | 20         |
| 6     | 1(RS232)              | 38400          | 1        | no     | 20         |
| 7     | 1(RS232)              | 9600           | 2        | no     | 2          |
| 8     | 1(RS232)              | 9600           | 1        | no     | 2          |
| 9     | 1(RS232)              | 9600           | 2        | no     | 20         |
| 10    | 1(RS232)              | 9600           | 1        | no     | 20         |
| 11    | 2(RS485)              | 38400          | 2        | no     | 2          |
| 12    | 2(RS485)              | 38400          | 1        | no     | 2          |
| 13    | 2(RS485)              | 38400          | 2        | no     | 20         |
| 14    | 2(RS485)              | 38400          | 1        | no     | 20         |
| 15    | 2(RS485)              | 9600           | 2        | no     | 2          |
| 16    | 2(RS485)              | 9600           | 1        | no     | 2          |
| 17    | 2(RS485)              | 9600           | 2        | no     | 20         |
| 18    | 2(RS485)              | 9600           | 1        | no     | 20         |
| 19    | Dial Out analog modem |                |          |        |            |
| 20    | Dial Out GSM modem    |                |          |        |            |

## 57. EEPROM MENU

### 57.1. Overview

The drive has four different memory zones:

- **RAM** → Volatile memory containing the drive’s current parameterization;
- **Default Zone** → Non-volatile memory that cannot be accessed by the user, containing the factory-setting of the drive parameters.
- **Work Zone** → Non-volatile memory where customized parameters are saved. Whenever the drive is reset, this parameterization is loaded to the RAM.
- **Back-up Zone** → Non-volatile memory storing a new drive parameterization. Back-up parameters are modified only when the user explicitly saves the back-up zone.

Any parameter can be changed by the user. The drive will immediately use the new parameter value.

The user may save the parameter value in the Work zone. If no new value is saved for a given parameter, the drive will use the parameter value stored in the Work zone when next turned on.

- “P” parameters can be written at any moment.
- According to factory-setting, “C” parameters may be written when the equipment is on stand-by or when the motor is not running and the equipment is fluxing. See **P003** to modify them only when the **ENABLE-A** and **ENABLE-B** commands are deactivated (terminal **MDI2** open).
- “R” parameters have the same features as “C” parameters, but the new parameter value, once written and saved, will be used only at next power on. To use the new parameter value immediately, turn the drive off and on or press the **RESET** key for at least 5 seconds.

The Work zone may be copied to the BACKUP zone through **I012** included in the Eeprom menu and described in the section below.

**I012** input also allows copying the Backup zone to the WORK zone in order to restore the parameter values stored in the WORK zone.

**I012** input also allows restoring the factory-setting values for all parameters in the WORK zone.

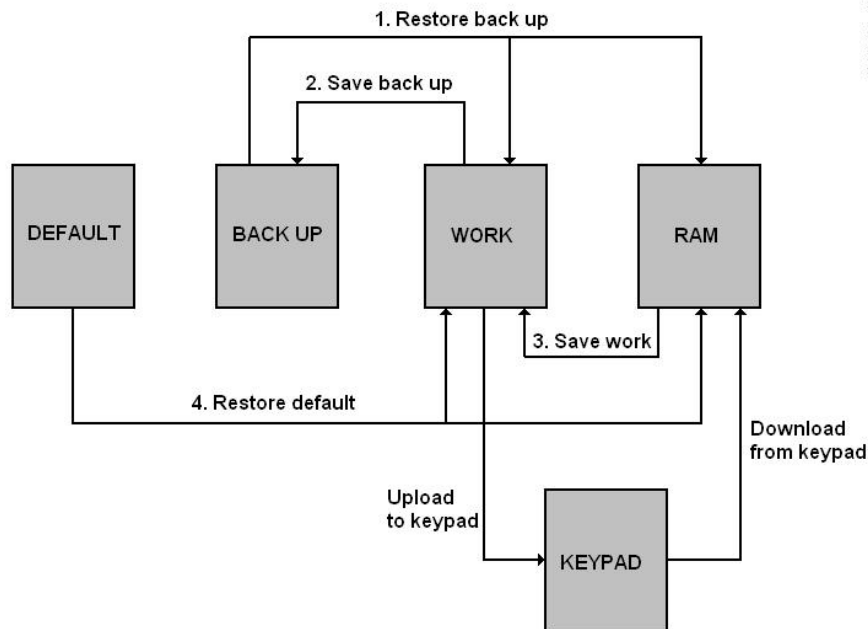

## 57.2. List of Inputs I009 to I012

Table 127: List of programmable inputs I009 to I012

| Input | FUNCTION       | User Level | MODBUS Address |
|-------|----------------|------------|----------------|
| I009  | Parameter save | BASIC      | 1396           |
| I012  | EEPROM control | BASIC      | 1399           |

### I009 Parameter save

| I009 | Range    | 131 ÷ 2466   | 131 ÷ 2466 |
|------|----------|--|------------|
|      | Default  | This is not a parameter: at power on and whenever the EEPROM command is executed, I009 is set to zero.   |            |
|      | Level    | BASIC  |            |
|      | Address  | 1396   |            |
|      | Function | Allows only one parameter to be saved to EEPROM.<br>The value to be saved must be the same as the value set in the Address field of the parameter concerned. |            |

### I012 EEPROM Control

| I012 | Range    | 0, 2, 4, 5, 11  | 0: No Command<br>2: Restore Backup<br>4: Save Backup<br>5: Save Work<br>11: Restore Default |
|------|----------|---|---|
|      | Default  | This is not a parameter: at power on and whenever the EEPROM command is executed, I012 is set to zero.  |   |
|      | Level    | BASIC   |   |
|      | Address  | 1399  |   |
|      | Function | <p>This parameter saves and restores the entire set of parameters that can be accessed by the user:</p> <p><b>2: Restore Backup:</b> the parameters stored in the Backup zone are copied and stored in the WORK zone. They represent the new RAM parameterization; the previous RAM parameters are cleared. <b>Backup → RAM → Work;</b></p> <p><b>4: Save Backup:</b> the parameters in the WORK zone are saved to a copy of the Backup zone. <b>Work → Backup;</b></p> <p><b>5: Save Work:</b> the current values of the parameters stored in the RAM zone are saved to non-volatile memory in the Work zone. All the parameters are saved with this command. <b>RAM → Work;</b></p> <p><b>11: Restore Default:</b> factory-setting values are restored for all parameters; each factory-setting value is stored to non-volatile memory in the Work zone. <b>Default → RAM → Work.</b></p> |   |

## 58. ALARMS AND WARNINGS



### CAUTION

If a protection trips or the drive enters the emergency mode, the drive is locked and the motor starts idling!

### 58.1. What Happens When a Protection Trips

---



### NOTE

Before operating the drive in emergency conditions, carefully read this section and the following section, **What To Do When an Alarm Trips**.

The drive alarms are detailed below.

When a protection / alarm trips:

- 1) the **ALARM** LED on the keypad comes on;
- 2) the page displayed on the keypad is the root page of the **FAULT LIST**;
- 3) the **FAULT LIST** is refreshed;
- 4) when using the Drive Profile board, the drive reports faults as hexadecimal values, which are assigned and coded according to the DRIVECOM specification. See Table 131.

In factory-setting, when the drive is switched on after an alarm has tripped—which has not been reset—it is kept in emergency condition.

**If the drive is in emergency mode when switched on, this could be due to an alarm tripped before the drive was reset.**

To avoid storing the alarms tripped before the drive is switched off, set parameter **C257** in the **Autoreset Menu**.

The drive stores the moment when an alarm trips to the **FAULT LIST** (supply-time and operation-time). The drive status when the alarm tripped and some measures sampled when the alarm tripped are also stored to the Fault List.

The readout and storage of the fault list can be very useful to detect the cause responsible for the alarm and its possible solution (see also the Fault List Menu).



### NOTE

Alarms **A001** to **A039** relate to the main microcontroller (DSP Motorola) of the control board, which detected a fault on the control board itself. No fault list is available for Alarms **A001** to **A039** and no Reset command can be sent via serial link; alarms can be reset through the **RESET** terminal on the terminal board or the **RESET** key on the keypad. No software for the keypad interface is available; the drive parameters and measures cannot be accessed via serial link.

Avoid resetting alarms **A033** and **A039**, as they trip when the flash memory is not provided with its correct software. Alarms **A033** and **A039** can be reset only when proper software is downloaded for the the inverter flash memory.

Before resetting an alarm, deactivate the **ENABLE-A** and **ENABLE-B** signals on terminal **MD12** to disable the inverter and prevent the connected motor from running at uncontrolled speed, unless parameter **C181**=1 (the Safety Start function is active): after resetting an alarm or after supplying the inverter, this will start only if the **ENABLE-A** and **ENABLE-B** contacts are opened and closed again.



### CAUTION

## 58.2. What To Do When an Alarm Trips

---

**CAUTION**

If a protection trips or the drive is in emergency condition, the drive is locked and the motor starts idling!

**CAUTION**

Before resetting an alarm, disable the **ENABLE-A** and **ENABLE-B** signals on terminal **MDI2** to disable the drive and to prevent the connected motor from running at uncontrolled speed.

### Proceed as follows:

1. Disable the **ENABLE-A** and **ENABLE-B** signals on terminal **MDI2** to disable the drive and to lock the motor, unless parameter **C181=1** (the Safety Start function is active): after resetting an alarm or after supplying the drive, this will start only if the **ENABLE-A** and **ENABLE-B** contacts are open and closed.
2. If the motor is idling, wait until it stops.

Check the **FAULT LIST** carefully for any information about the alarm tripped, in order to determine the cause responsible for the alarm and its possible solutions.

**Any information stored to the FAULT LIST is also required when contacting Elettronica Santerno's Customer Service.**

3. In the following sections, find the relative alarm code and follow the instructions.
4. Solve any external problems that may have been responsible for the protection trip.
5. If the alarm tripped due to the entry of wrong parameter values, set new correct values and save them.
6. Reset the alarm.
7. If the alarm condition persists, please contact Elettronica Santerno Customer Service.

A **RESET** command must be sent to reset the alarms tripped. Do one of the following:

- Enable the **RESET** signal in **MDI3** terminal in the hardware terminal board;
- Press the **RESET** key on the keypad;
- Enable the **RESET MDI3** signal in one of the virtual terminal boards enabled as remote control sources (see the CONTROL METHOD MENU).

To activate the **Autoreset** function, enable parameter **C255** (see the AUTORESET MENU); the drive will automatically try to reset the alarms tripped.

### 58.3. Alarm List

Table 128: List of the possible alarms

| Alarm       | Alarm Message             | Description   |
|-------------|---------------------------|---|
| A001 ÷ A032 | ...                       | <i>Control board failure</i>  |
| A033        | TEXAS VER KO              | Incompatible Texas Software Version   |
| A039        | FLASH KO                  | Texas Flash not programmed  |
| A040        | User Fault                | Alarm caused by the user  |
| A041        | PWMA Fault                | General hardware fault from IGBT, side A  |
| A042        | Illegal XMDI in DGI       | Illegal configuration of XMDI in the Digital Inputs menu  |
| A043        | False Interrupt           | <i>Control board failure</i>  |
| A044        | SW OverCurrent            | Software overcurrent  |
| A045        | Bypass Circuit Fault      | Fault of the precharge By-Pass  |
| A046        | Bypass Connector Fault    | Precharge By-Pass connector fault   |
| A047        | UnderVoltage              | Dc bus voltage lower than Vdc_min   |
| A048        | OverVoltage               | Dc bus voltage exceeding Vdc_max  |
| A049        | RAM Fault                 | <i>Control board failure</i>  |
| A050        | PWMA0 Fault               | Hardware Fault from IGBT converter, side A  |
| A051        | PWMA1 Fault               | Hardware overcurrent, side A  |
| A052        | Illegal XMDI in DGO       | Illegal configuration of XMDI in the Digital Outputs menu   |
| A053        | PWMA Not ON               | Hardware failure, IGBT A power on impossible  |
| A054        | Optional Board not in     | Failure in detecting preset optional I/O board  |
| A055        | PTC Alarm                 | External PTC tripped  |
| A056        | PTC Short Circuit         | External PTC in short circuit   |
| A057        | Illegal XMDI in MPL       | Illegal configuration of XMDI in the Virtual Digital Outputs (MPL) menu   |
| A059        | Encoder Fault             | Error of motor speed measure  |
| A060        | NoCurrent Fault           | Current is zero in FOC control  |
| A061        | Ser WatchDog              | Watchdog tripped in serial link 0 (9-pole D connector)  |
| A062        | SR1 WatchDog              | Watchdog tripped in serial link 1 (RJ45)  |
| A063        | Generic Motorola          | <i>Control board failure</i>  |
| A064        | Mains Loss                | No power is supplied from the mains   |
| A065        | AutoTune Fault            | Autotune failed   |
| A066        | REF < 4mA                 | REF Current input (4÷20mA) lower than 4mA   |
| A067        | AIN1 < 4mA                | AIN1 Current input (4÷20mA) lower than 4mA  |
| A068        | AIN2 < 4mA                | AIN2 Current input (4÷20mA) lower than 4mA  |
| A069        | XAIN5 < 4mA               | XAIN5 Current input (4÷20mA) lower than 4mA   |
| A070        | Fbs WatchDog              | Fieldbus Watchdog tripped   |
| A071        | 1ms Interrupt OverTime    | <i>Control board failure</i>  |
| A072        | Parm Lost Chk             | Parameter download/upload error   |
| A073        | Parm Lost COM1            | Parameter download/upload error   |
| A074        | Drive OverHeated          | Drive thermal protection tripped  |
| A075        | Motor OverHeated          | Motor thermal protection tripped  |
| A076        | Speed Alarm               | Motor speed too high  |
| A078        | MMI Trouble               | <i>Control board failure</i>  |
| A079        | Encoder not conf.         | FOC control but Encoder not properly configured   |
| A080        | Tracking Error            | Encoder speed tracking error  |
| A081        | KeyPad WatchDog           | Communication watchdog via keypad   |
| A082        | Illegal Encoder Cfg       | Functions programmed for MDI6 and MDI7 or encoder B selected and encoder board not detected.                            |
| A083        | External Alarm 1          | External alarm 1  |
| A084        | External Alarm 2          | External alarm 2  |
| A085        | External Alarm 3          | External alarm 3  |
| A086        | XAIN5 > 20mA              | XAIN5 Current input (4÷20mA or 0÷20mA) greater than 20mA  |
| A087        | ±15V LOSS                 | ± 15V Loss  |
| A088        | ADC Not Tuned             | <i>Control board failure</i>  |
| A089        | Parm Lost COM2            | Parameter download/upload error   |
| A090        | Parm Lost COM3            | Parameter download/upload error   |
| A091        | Braking Resistor Overload | Overvoltage tripped with braking resistor activated due to continuous operation time exceeding the max. programmed time |

| Alarm       | Alarm Message               | Description   |
|-------------|-----------------------------|---|
| A092        | SW Version KO               | Control board failure   |
| A093        | Bypass Circuit Open         | By-Pass relay open  |
| A094        | HeatSink Overheated         | IGBT heatsink temperature too high                              |
| A095        | Illegal Drive Profile Board | Drive Profile board not correctly configured                    |
| A096        | Fan Fault                   | Fault of the cooling fans                                       |
| A097        | Motor Not Connected         | Motor not connected   |
| A098        | Illegal Motor Selected      | Illegal motor selected via MDI                                  |
| A099        | 2nd Sensor Fault            | Fault of fan sensor 2   |
| A100        | MDI6 Illegal Configuration  | Function programmed for MDI6 along with frequency input A       |
| A101        | MDI8 Illegal Configuration  | Function programmed for MDI8 along with frequency input B       |
| A102        | REF > 20mA                  | REF Current input (4÷20mA or 0÷20mA) greater than 20mA          |
| A103        | AIN1 > 20mA                 | AIN1 Current input (4÷20mA or 0÷20mA) greater than 20mA         |
| A104        | AIN2 > 20mA                 | AIN2 Current input (4÷20mA or 0÷20mA) greater than 20mA         |
| A105        | PT100 Channel 1 Fault       | Hardware address out of measure range of the drive              |
| A106        | PT100 Channel 2 Fault       | Hardware address out of measure range of the drive              |
| A107        | PT100 Channel 3 Fault       | Hardware address out of measure range of the drive              |
| A108        | PT100 Channel 4 Fault       | Hardware address out of measure range of the drive              |
| A109        | Amb.Overtemp.               | Ambient overtemperature   |
| A110 ÷ A120 | ...                         | Control board failure   |
| A129        | No Output Phase             | Output phase loss   |
| A140        | Torque Off not Safe         | Malfunctioning of ENABLE-A and ENABLE-B inputs for STO function |

**A001 ÷ A032, A043, A049, A063, A071, A078, A088, A092, A110÷A120 Control Board Failure**

|   |                |   |
|---|----------------|---|
| <b>A001 ÷ A032</b><br>A043<br>A049<br>A063<br>A071<br>A078<br>A088<br>A092<br>A110 ÷ A120 | Description    | Control board failure   |
|   | Event          | There may be several causes: the board autodiagnosics file constantly checks its operating conditions.  |
|   | Possible cause | <ul style="list-style-type: none"> <li>• Strong electromagnetic disturbance or radiated interference.</li> <li>• Possible failure of the microcontroller or other circuits on the control board.</li> </ul> |
|   | Solution       | 1. Reset the alarm: send a <b>RESET</b> command.<br>2. If the alarm persists, please contact ELETTRONICA SANTERNO's Customer Service.   |

**A033 Texas Software KO**

|             |                |  |
|-------------|----------------|--|
| <b>A033</b> | Description    | Incompatible Software Texas version  |
|             | Event          | When switched on, DSP Motorola detected an incompatible version of the software downloaded to Flash Texas (software version incompatible with Motorola). |
|             | Possible cause | The wrong software was downloaded.   |
|             | Solution       | 1. Download the correct DSP Texas software version.<br>2. If the alarm persists, please contact ELETTRONICA SANTERNO's Customer Service.                 |

**A039 Texas Flash not Programmed**

|             |                       |  |
|-------------|-----------------------|--|
| <b>A039</b> | <b>Description</b>    | Texas Flash not programmed   |
|             | <b>Event</b>          | When switched on, DSP Motorola detected that Flash Texas is not correctly programmed.  |
|             | <b>Possible cause</b> | A prior attempt to download DSP Texas software failed.   |
|             | <b>Solution</b>       | 1. Download the correct DSP Texas software version.<br>2. If the alarm persists, please contact ELETTRONICA SANTERNO's Customer Service. |

**A040 User Alarm**

|             |                       |   |
|-------------|-----------------------|---|
| <b>A040</b> | <b>Description</b>    | Alarm trip caused by the user (as a testing procedure)      |
|             | <b>Event</b>          | The user has forced the alarm to trip.                      |
|             | <b>Possible cause</b> | Value 1 was entered to address MODBUS 1400 via serial link. |
|             | <b>Solution</b>       | Reset the alarm: send a <b>RESET</b> command.               |

**A041 IGBT Fault Side A**

|             |                       |   |
|-------------|-----------------------|---|
| <b>A041</b> | <b>Description</b>    | General hardware fault from IGBT, side A  |
|             | <b>Event</b>          | Power converter A generated a general alarm.  |
|             | <b>Possible cause</b> | <ul style="list-style-type: none"> <li>• Electromagnetic disturbance or radiated interference.</li> <li>• Overcurrent, IGBT overtemperature, IGBT fault.</li> </ul> |
|             | <b>Solution</b>       | 1. Reset the alarm: send a <b>RESET</b> command.<br>2. If the alarm persists, please contact ELETTRONICA SANTERNO's Customer Service.                               |

**A042 Illegal XMDI in DGI**

|             |                       |  |
|-------------|-----------------------|--|
| <b>A042</b> | <b>Description</b>    | Illegal configuration of XMDI in the Digital Inputs menu.  |
|             | <b>Event</b>          | <ul style="list-style-type: none"> <li>• The drive checked if at least one XMDI input from ES847 or ES870 I/O optional board is available in the DIGITAL INPUTS MENU;</li> <li>• The drive checked if <b>R023</b> (I/O Board setting) is set to 0 in the EXPANSION BOARD CONFIGURATION MENU</li> </ul> |
|             | <b>Possible cause</b> | Wrong settings.  |
|             | <b>Solution</b>       | Check settings and enter correct settings.   |

**A044 SW Overcurrent**

|             |                       |  |
|-------------|-----------------------|--|
| <b>A044</b> | <b>Description</b>    | SW Overcurrent   |
|             | <b>Event</b>          | Immediate current limit tripped  |
|             | <b>Possible cause</b> | <ul style="list-style-type: none"> <li>Abrupt variations of the connected load</li> <li>Output short-circuit or ground short-circuit</li> <li>Strong electromagnetic disturbance or radiated interference.</li> </ul> <p>If alarm <b>A044</b> tripped while accelerating:</p> <ul style="list-style-type: none"> <li>Too short acceleration ramp;</li> </ul> <p>If alarm <b>A044</b> tripped while decelerating:</p> <ul style="list-style-type: none"> <li>Too short deceleration ramp.</li> <li>Excessive gain of the current regulator (<b>P155</b>) or too short integral time (<b>P156</b>) when using the <b>FOC</b> control algorithm.</li> <li>Excessive gain of the speed regulator (<b>P128</b>) or too short integral time (<b>P126</b>) when using the <b>VTC</b> control algorithm.</li> </ul>  |
|             | <b>Solution</b>       | <ol style="list-style-type: none"> <li>1. Check if the drive and the motor are properly dimensioned with respect to the connected load.</li> <li>2. Make sure that no output short-circuit is to be found between two phases or between one phase and the grounding (terminals <b>U, V, W</b>). (Remove voltage from the motor, set IFD control and operate the drive in no-load conditions.)</li> <li>3. Check if the command signals are sent to the drive using screened cables where required (see Sinus Penta's Installation Guide). Detect external sources for electromagnetic disturbance, check wiring and make sure that antidisturbance filters are installed on the coils of contactors and electrovalves (if fitted inside the cabinet).</li> <li>4 If necessary, set longer acceleration times (see the RAMPS MENU).</li> <li>5 If necessary, set longer deceleration times (see the RAMPS MENU).</li> <li>6. If necessary, decrease the values set in the LIMITS MENU.</li> </ol> |

**A045 Bypass Circuit Fault**

|             |                       |   |
|-------------|-----------------------|---|
| <b>A045</b> | <b>Description</b>    | Bypass precharge Fault  |
|             | <b>Event</b>          | The drive forced to close its relay or contactor for the short-circuit of the precharge resistors in DC-link capacitors (DC bus), but it <u>did not detect the relevant closing signal</u> while precharging.<br>See also <b>A046</b> . |
|             | <b>Possible cause</b> | <ul style="list-style-type: none"> <li>Disconnection of auxiliary signal.</li> <li>Precharge relay/contactor failure.</li> </ul>  |
|             | <b>Solution</b>       | <ol style="list-style-type: none"> <li>1. Reset the alarm: send a <b>RESET</b> command.</li> <li>2. If the alarm persists, please contact ELETTRONICA SANTERNO's Customer Service.</li> </ol>   |

**A046 Bypass Connector Fault**

|             |                       |   |
|-------------|-----------------------|---|
| <b>A046</b> | <b>Description</b>    | Precharge bypass connector fault.   |
|             | <b>Event</b>          | Auxiliary signal for the closing of the bypass connector of the short-circuit precharge resistor is considered as closed before the relevant closing command is sent. See also <b>A045</b> .  |
|             | <b>Possible cause</b> | <ul style="list-style-type: none"> <li>• Precharge bypass connector reversed.</li> <li>• Precharge relay/contactor failure.</li> </ul>  |
|             | <b>Solution</b>       | <ol style="list-style-type: none"> <li>1. Reset the alarm: send a <b>RESET</b> command.</li> <li>2. If the alarm persists, please contact ELETTRONICA SANTERNO's Customer Service.</li> </ol> |

**A047 Undervoltage**

|             |                       |   |
|-------------|-----------------------|---|
| <b>A047</b> | <b>Description</b>    | DC bus Voltage lower than minimum voltage.  |
|             | <b>Event</b>          | Voltage measured in DC bus capacitors has dropped below the min. value allowed for a proper operation of the drive class being used.  |
|             | <b>Possible cause</b> | <ul style="list-style-type: none"> <li>• Supply voltage has dropped below 200Vac–15% (class 2T), 380V–15% (class 4T), 500V –15% (class 5T), 600Vac –5% (class 6T).</li> <li>• Alarm <b>A047</b> can trip even when voltage temporarily drops below the allowable min. value (which is caused for example by the direct starting of the connected load).</li> <li>• If the drive is powered directly by the bus bar, the bus feeder is responsible for the alarm.</li> <li>• Failure in DC bus voltage measure circuit.</li> </ul> |
|             | <b>Solution</b>       | <ol style="list-style-type: none"> <li>1. Check voltage in terminals <b>R, S, T</b>. Check mains voltage value <b>M030</b> and DC bus voltage value <b>M029</b>. Also check the values of <b>M030</b> and <b>M029</b> sampled in the <b>FAULT LIST</b> when the alarm tripped.</li> <li>2. If the alarm persists, please contact ELETTRONICA SANTERNO's Customer Service.</li> </ol>  |

**A048 Overvoltage**

|             |                       |   |
|-------------|-----------------------|---|
| <b>A048</b> | <b>Description</b>    | Overvoltage in DC bus (voltage in DC-link).   |
|             | <b>Event</b>          | Voltage measured in DC bus (DC-link) capacitors has exceeded the max. value allowed for a proper operation of the drive class being used.   |
|             | <b>Possible cause</b> | <ul style="list-style-type: none"> <li>• Check that voltage does not exceed 240Vac +10% (class 2T), 500Vac +10% (class 4T), 600Vac +10% (class 5T), 690Vac +10% (class 6T).</li> <li>• Very inertial loads and a too short deceleration ramp (see the RAMPS MENU).</li> <li>• Alarm <b>A048</b> can trip even when the motor is pulled by the load (eccentric load).</li> <li>• If the drive is powered directly by the bus bar, the bus feeder is responsible for the alarm trip.</li> <li>• Failure in DC bus voltage measure circuit.</li> </ul>   |
|             | <b>Solution</b>       | <ol style="list-style-type: none"> <li>1. Check voltage in terminals <b>R, S, T</b>. Check mains voltage value <b>M030</b> and DC bus voltage value <b>M029</b>. Also check the values of <b>M030</b> and <b>M029</b> sampled in the <b>FAULT LIST</b> when the alarm tripped.</li> <li>2. In case of very inertial loads and if the alarm tripped when decelerating, try to set a longer deceleration ramp. If short stop times are needed or if the motor is pulled by the load, activate the resistive braking unit.</li> <li>3. If the alarm persists, please contact ELETTRONICA SANTERNO's Customer Service.</li> </ol> |

**A050 IGBT Fault A**

|             |                       |  |
|-------------|-----------------------|--|
| <b>A050</b> | <b>Description</b>    | Hardware fault from IGBT converter, side A, or brake overcurrent   |
|             | <b>Event</b>          | The IGBT drivers of power converter A have detected IGBT failure or overcurrent conditions in the brake circuit (models S14, S22, S32 5T/6T only)  |
|             | <b>Possible cause</b> | <ul style="list-style-type: none"> <li>• Strong electromagnetic disturbance or radiated interference.</li> <li>• Overcurrent, Overtemperature, IGBTs, IGBT fault.</li> <li>• Unsuitable braking resistor (models S14, S22, S32 5T/6T only).</li> </ul> |
|             | <b>Solution</b>       | <ol style="list-style-type: none"> <li>1. Reset the alarm: send a <b>RESET</b> command.</li> <li>2. If the alarm persists, please contact ELETTRONICA SANTERNO's Customer Service.</li> </ol>  |

**A051 Overcurrent HW A**

|             |                       |  |
|-------------|-----------------------|--|
| <b>A051</b> | <b>Description</b>    | Hardware overcurrent, side A.                                      |
|             | <b>Event</b>          | Hardware overcurrent detected by the drive output current circuit. |
|             | <b>Possible cause</b> | See <b>A044 SW Overcurrent</b> .                                   |
|             | <b>Solution</b>       | See <b>A044 SW Overcurrent</b> .                                   |

**A052 Illegal XMDI in DGO**

|             |                       |  |
|-------------|-----------------------|--|
| <b>A052</b> | <b>Description</b>    | Illegal configuration of XMDI in the Digital Outputs menu.   |
|             | <b>Event</b>          | <ul style="list-style-type: none"> <li>The drive checked if at least one XMDI input from ES847 or ES870 I/O optional board is available in the DIGITAL INPUTS MENU;</li> <li>The drive checked if <b>R023</b> (I/O Board setting) is set to 0 in the EXPANSION BOARD CONFIGURATION MENU</li> </ul> |
|             | <b>Possible cause</b> | Wrong settings.  |
|             | <b>Solution</b>       | Check settings and enter correct settings.   |

**A053 Not PWONA**

|             |                       |   |
|-------------|-----------------------|---|
| <b>A053</b> | <b>Description</b>    | Hardware failure; IGBT A power on failure.  |
|             | <b>Event</b>          | IGBT A power on controlled by Motorola microcontroller has failed.  |
|             | <b>Possible cause</b> | Control board failure.  |
|             | <b>Solution</b>       | <ol style="list-style-type: none"> <li>Reset the alarm: send a <b>RESET</b> command.</li> <li>If the alarm persists, please contact ELETTRONICA SANTERNO's Customer Service.</li> </ol> |

**A054 Optional Board not in**

|             |                       |   |
|-------------|-----------------------|---|
| <b>A054</b> | <b>Description</b>    | ES847 or ES870 not in.  |
|             | <b>Event</b>          | The control board detects no ES847 or ES870 I/O expansion boards after parameter <b>R023</b> (I/O Board Setting) is set as $\neq 0$ .   |
|             | <b>Possible cause</b> | Optional board not in or faulty.  |
|             | <b>Solution</b>       | <ol style="list-style-type: none"> <li>Check consistency of parameter <b>R023</b> (see the EXPANSION BOARD CONFIGURATION MENU).</li> <li>Reset the alarm: send a <b>RESET</b> command.</li> <li>If the alarm persists, please contact ELETTRONICA SANTERNO's Customer Service.</li> </ol> |

**A055 PTC Alarm**

|             |                       |  |
|-------------|-----------------------|--|
| <b>A055</b> | <b>Description</b>    | External PTC resistor tripped.   |
|             | <b>Event</b>          | The drive detected the opening of the PTC connected to <b>AIN2</b> input ( $R > 3600$ ohm)   |
|             | <b>Possible cause</b> | <ul style="list-style-type: none"> <li>Opening of the PTC due to motor overheating.</li> <li>Incorrect wiring of PTC.</li> <li>Incorrect setting of <b>SW1</b> hardware switch on the control board (see Installation Guide).</li> </ul>   |
|             | <b>Solution</b>       | <ol style="list-style-type: none"> <li>Allow the motor to cool, then reset the alarm.</li> <li>Make sure that the PTC is correctly connected to <b>AIN2</b> analog input (see Installation Guide).</li> <li>Make sure that <b>SW1</b> hardware switch is correctly set.</li> </ol> |

**A056 PTC Short Circuit**

|             |                       |  |
|-------------|-----------------------|--|
| <b>A056</b> | <b>Description</b>    | External PTC resistor short circuit.   |
|             | <b>Event</b>          | Detected the short circuit of the PTC connected to <b>AIN2</b> input ( $R < 10$ ohm).  |
|             | <b>Possible cause</b> | <ul style="list-style-type: none"> <li>• Short circuit in the PTC.</li> <li>• Incorrect wiring of PTC.</li> <li>• Incorrect setting of <b>SW1</b> hardware switch on the control board (see Installation Guide).</li> </ul>      |
|             | <b>Solution</b>       | <ol style="list-style-type: none"> <li>1. Make sure that the PTC is correctly connected to <b>AIN2</b> analog input (see Installation Guide).</li> <li>2. Make sure that <b>SW1</b> hardware switch is correctly set.</li> </ol> |

**A057 Illegal XMDI in MPL**

|             |                       |   |
|-------------|-----------------------|---|
| <b>A057</b> | <b>Description</b>    | Illegal configuration of XMDI in the Virtual Digital Outputs (MPL) Menu.  |
|             | <b>Event</b>          | <ul style="list-style-type: none"> <li>• The drive checked if at least one XMDI input from ES847 or ES870 I/O optional board is available in the VIRTUAL DIGITAL OUTPUTS (MPL) MENU;</li> <li>• The drive checked if <b>R023</b> (I/O Board setting) is set to 0 in the EXPANSION BOARD CONFIGURATION MENU</li> </ul> |
|             | <b>Possible cause</b> | Wrong settings.   |
|             | <b>Solution</b>       | Check settings and enter correct settings.  |

**A059 Encoder Fault**

|             |                       |   |
|-------------|-----------------------|---|
| <b>A059</b> | <b>Description</b>    | Motor speed measure error.  |
|             | <b>Event</b>          | During the encoder tune, a speed error measure occurred with respect to the estimated speed, although the sign of the measured speed is consistent with the estimated speed.  |
|             | <b>Possible cause</b> | <ul style="list-style-type: none"> <li>• Incorrect parameterization of the encoder concerning the type and number of pulses/rev.</li> <li>• Voltage removed from one of the two encoders.</li> <li>• Incorrect mounting of the encoders.</li> <li>• Encoder failure.</li> </ul>   |
|             | <b>Solution</b>       | <ol style="list-style-type: none"> <li>1. Check that the encoder parameters are correct (see the ENCODER/FREQUENCY INPUTS MENU).</li> <li>2. Check that both encoders are properly connected.</li> <li>3. Check mounting of the encoders.</li> <li>4. Using an oscilloscope, check that the encoder signals are correct.</li> </ol> |

**A060 No Current Fault (FOC)**

|             |                       |   |
|-------------|-----------------------|---|
| <b>A060</b> | <b>Description</b>    | The error detected in FOC control by the current loop exceeds the max. allowable value.   |
|             | <b>Event</b>          | The FOC control detected a current regulation error.  |
|             | <b>Possible cause</b> | <ul style="list-style-type: none"> <li>One motor cable is disconnected.</li> <li>Failure in the current measure circuit.</li> <li>Wrong setting of current regulator parameters for FOC control.</li> </ul>   |
|             | <b>Solution</b>       | <ol style="list-style-type: none"> <li>1. Check motor connections (terminals <b>U, V, W</b>).</li> <li>2. Check parameterization of current regulators for FOC control (see the FOC REGULATORS MENU). Perform a new current regulator autotune (see AUTOTUNE MENU).</li> <li>3. If the alarm persists, please contact ELETTRONICA SANTERNO's Customer Service.</li> </ol> |

**A061, A062 Serial Link Watchdog**

|  |                       |   |
|--|-----------------------|---|
| <b>A061 (Serial Link 0)<br/>A062 (Serial Link 1)</b> | <b>Description</b>    | <b>A061:</b> Serial Link Watchdog 0 tripped<br><b>A062:</b> Serial Link Watchdog 1 tripped  |
|  | <b>Event</b>          | <p>The serial link watchdog has tripped.</p> <p>Communication failure: no read/write query sent to serial link for a time longer than the time set in the parameters relating to serial link watchdog (see the SERIAL LINKS MENU).</p> <p>This alarm does not trip if, due to parameters in the CONTROL METHOD MENU or due to the status of the source selection or LOC/REM inputs (DIGITAL INPUTS MENU), the information sent from serial link is not currently used for the commands or the references.</p> |
|  | <b>Possible cause</b> | <ul style="list-style-type: none"> <li>Serial link is disconnected.</li> <li>Communication failure on remote master side.</li> <li>Watchdog operating times too short.</li> </ul>   |
|  | <b>Solution</b>       | <ol style="list-style-type: none"> <li>1. Check serial link.</li> <li>2. Make sure that the remote master constantly sends read/write queries with max. intervals between two queries lower than the preset watchdog operating time.</li> <li>3. Set longer watchdog operating times (see <b>R005</b> for serial link 0 and <b>R012</b> for serial link 1).</li> </ol>  |

**A064 Mains Loss**

|             |                       |   |
|-------------|-----------------------|---|
| <b>A064</b> | <b>Description</b>    | Mains loss  |
|             | <b>Event</b>          | Mains loss.   |
|             | <b>Possible cause</b> | <ul style="list-style-type: none"> <li>One supply cable is disconnected.</li> <li>Mains supply too weak.</li> <li>Mains gap.</li> </ul>   |
|             | <b>Solution</b>       | <ol style="list-style-type: none"> <li>1. Check voltage in terminals <b>R, S, T</b>. Check mains voltage value <b>M030</b>. Also check the value of <b>M030</b> sampled in the <b>FAULT LIST</b> when the alarm tripped.</li> <li>2. This protection may be disabled or delayed (see the POWER DOWN MENU).</li> </ol> |

**A065 Autotune KO**

|             |                       |   |
|-------------|-----------------------|---|
| <b>A065</b> | <b>Description</b>    | Autotune failed.  |
|             | <b>Event</b>          | Autotune aborted or failed.   |
|             | <b>Possible cause</b> | <ul style="list-style-type: none"> <li>• The <b>ENABLE</b> contact was disabled before autotune was over.</li> <li>• Autotune aborted, maybe because the parameter values were inconsistent with the motor ratings.</li> </ul>  |
|             | <b>Solution</b>       | <ol style="list-style-type: none"> <li>1. Reset the alarm: send a <b>RESET</b> command.</li> <li>2. Check the motor parameters and make sure that they are consistent with the motor ratings (see the MOTOR CONFIGURATION MENU) and perform a new autotune procedure.</li> <li>3. If the alarm persists, please contact ELETTRONICA SANTERNO's Customer Service.</li> </ol> |

**A066, A067, A068, A069 Current input < 4mA**

|  |                       |   |
|--|-----------------------|---|
| <b>A066 (REF)<br/>A067 (AIN1)<br/>A068 (AIN2)<br/>A069 (XAIN5)</b> | <b>Description</b>    | <p><b>A066:</b> REF Current input (4÷20mA) lower than 4mA<br/> <b>A067:</b> AIN1 Current input (4÷20mA) lower than 4mA<br/> <b>A068:</b> AIN2 Current input (4÷20mA) lower than 4mA<br/> <b>A069:</b> XAIN5 current input (4÷20mA) lower than 4mA</p> |
|  | <b>Event</b>          | A current value lower than 4 mA has been detected over one input (REF, AIN1, AIN2, XAIN5) set with the following range: 4÷20mA.   |
|  | <b>Possible cause</b> | <ul style="list-style-type: none"> <li>• Wrong setting of <b>SW1</b> on the control board (except for <b>A069</b>).</li> <li>• Signal cable disconnected.</li> <li>• Failure in the current signal source.</li> </ul>                                 |
|  | <b>Solution</b>       | <ol style="list-style-type: none"> <li>1. Check setting of <b>SW1</b> (except for <b>A069</b>).</li> <li>2. Check that the signal cable is properly connected to its terminal.</li> <li>3. Check the current signal source.</li> </ol>                |



**NOTE** The alarms above trip only if the relevant inputs have been selected (see CONTROL METHOD MENU and PID CONFIGURATION MENU).

**A070 Fieldbus WatchDog**

|             |                       |   |
|-------------|-----------------------|---|
| <b>A070</b> | <b>Description</b>    | Watchdog Fieldbus tripped.  |
|             | <b>Event</b>          | The watchdog fieldbus tripped and communication is suspended. Communication is interrupted: the Master did not send any valid message for a time longer than the time set in the parameter relating to the value set with parameter <b>R016</b> of the fieldbus watchdog time (see the FIELDBUS CONFIGURATION MENU). This alarm does not trip if, due to parameters in the CONTROL METHOD MENU or due to the status of the source selection or LOC/REM inputs (DIGITAL INPUTS MENU), the information sent from fieldbus is not currently used for the commands or the references.   |
|             | <b>Possible cause</b> | <ul style="list-style-type: none"> <li>Voltage removed from Fieldbus.</li> <li>No communication from Master.</li> <li>Watchdog times too short.</li> </ul>  |
|             | <b>Solution</b>       | <ol style="list-style-type: none"> <li>1. Check fieldbus connections.</li> <li>2. Check that the master ensures a constant sequence of legal messages (FIELDBUS CONFIGURATION MENU) with max. time intervals lower than the preset watchdog time.</li> <li>3. Set longer watchdog times (see <b>R016</b>).</li> <li>4. To reset alarm <b>A070</b>, force communication between the Master and the Penta drive with bit 15 of the digital input word always set to 1 and reset the drive control board. If communication between the Master and the Slave (Penta) cannot be restored, alarm <b>A070</b> is restored after setting parameter R016 to zero and after resetting the Penta drive. When the drive is next powered on, the alarm reset will affect the drive control board.</li> </ol> |

**A072-3, A089-90 Parameter Upload/Download Error from Keypad to Drive**

|  |                       |   |
|--|-----------------------|---|
| <b>A072<br/>A073<br/>A089<br/>A090</b> | <b>Description</b>    | Upload/download failed, one of the controls of the parameter consistency detected a fault.                                  |
|  | <b>Event</b>          | A communication error occurred while uploading/downloading the programming parameters from the keypad to the drive.         |
|  | <b>Possible cause</b> | Temporary interruption to the serial link between keypad and control board.   |
|  | <b>Solution</b>       | Check the connection between the keypad and the control board, reset the alarm and perform a new upload/download procedure. |

**A074 Overload**

|             |                       |   |
|-------------|-----------------------|---|
| <b>A074</b> | <b>Description</b>    | Drive thermal protection tripped.   |
|             | <b>Event</b>          | The output current has been exceeding the drive rated current for long periods.   |
|             | <b>Possible cause</b> | <ul style="list-style-type: none"> <li>Current equal to <b>Ipeak</b> + 20% for <b>3 seconds</b>, or</li> <li>Current equal to <b>I<sub>max</sub></b> for <b>120 seconds</b> (S05÷S30 2T/4T),</li> <li>Current equal to <b>I<sub>max</sub></b> for <b>60 seconds</b> (S41÷S90 2T/4T and all the 5T/6T models)</li> </ul> |
|             | <b>Solution</b>       | Check the drive current output during ordinary operation ( <b>M026</b> in the <b>Measure Menu</b> ); check the mechanical conditions of the connected load (load locked / overload).  |

**A075 Motor Overheated**

|             |                       |   |
|-------------|-----------------------|---|
| <b>A075</b> | <b>Description</b>    | Motor thermal protection tripped.   |
|             | <b>Event</b>          | The software motor thermal protection tripped. Output current has been exceeding the motor rated current for long periods.  |
|             | <b>Possible cause</b> | <ul style="list-style-type: none"> <li>• Poor mechanical conditions of the connected load.</li> <li>• Wrong setting of parameters in the Thermal Protection Menu.</li> </ul>  |
|             | <b>Solution</b>       | <ol style="list-style-type: none"> <li>1. Check mechanical conditions of the connected load.</li> <li>2. Check parameters <b>C265</b>, <b>C266</b>, <b>C267</b> (and equivalent parameters for motors 2 and 3) in the MOTOR THERMAL PROTECTION MENU.</li> </ol> |

**A076 Limit Speed**

|             |                       |   |
|-------------|-----------------------|---|
| <b>A076</b> | <b>Description</b>    | The motor speed is too high.  |
|             | <b>Event</b>          | <p>The motor speed is higher than the current value set in parameter <b>C031</b> (for motor 1, or equivalent parameters for motors 2 and 3).</p> <p>If <b>C031</b> = 0, the limit speed protection is disabled.</p> <p>If the encoder is disabled, the variable used for this software protection is:</p> <ul style="list-style-type: none"> <li>• The current speed setpoint for IFD.</li> <li>• The estimated motor speed for VTC control.</li> </ul> |
|             | <b>Possible cause</b> | <ul style="list-style-type: none"> <li>• Value of parameter <b>C031</b> too low.</li> <li>• Torque reference too high for <b>SLAVE</b> mode.</li> </ul>   |
|             | <b>Solution</b>       | <ol style="list-style-type: none"> <li>1. Check the compatibility of the parameter with respect to the maximum speed parameter.</li> <li>2. In <b>SLAVE</b> mode, check the torque reference value.</li> </ol>  |

**A079 Encoder Not Configured**

|             |                       |  |
|-------------|-----------------------|--|
| <b>A079</b> | <b>Description</b>    | FOC control, but encoder not correctly configured.   |
|             | <b>Event</b>          | <p>The FOC control is active, but no encoder has been enabled with parameter <b>C012</b> (for motor 1, or equivalent parameters for motors 2 and 3). Otherwise, no incremental encoder enabled for speed measure with parameter <b>C189</b> (see the ENCODER/FREQUENCY INPUTS MENU).</p> <p>Otherwise, no position sensor on the expansion board has been configured via parameters <b>R023a</b>, <b>R023b</b>, <b>R092</b> to <b>R097</b> (see EXPANSION BOARD CONFIGURATION MENU).</p> |
|             | <b>Possible cause</b> | <ul style="list-style-type: none"> <li>• <b>C012</b> = 0 (for motor 1, or equivalent parameters for motors 2 and 3). See the MOTOR CONFIGURATION MENU.</li> <li>• The value set in <b>C189</b> does not enable any encoder for speed measure.</li> <li>• The <b>FOC</b> control has been improperly enabled.</li> <li>• Parameters <b>R023a</b>, <b>R023b</b>, <b>R092</b> to <b>R097</b> are not correctly set.</li> </ul>  |
|             | <b>Solution</b>       | Set parameters correctly.  |

**A080 Speed Tracking**

|             |                       |   |
|-------------|-----------------------|---|
| <b>A080</b> | <b>Description</b>    | Encoder speed measure error.  |
|             | <b>Event</b>          | The system detected an error between the measured speed and the measure setpoint. Speed has been exceeding the value set in parameter <b>C193</b> for a time longer than the value set in parameter <b>C192</b> .<br>This protection is enabled only if parameter <b>C194</b> is not set at zero.   |
|             | <b>Possible cause</b> | <ul style="list-style-type: none"> <li>• Wrong setting in parameters <b>C192</b>, <b>C193</b>, <b>C194</b> (see the ENCODER/FREQUENCY INPUTS MENU).</li> <li>• Torque limit too low.</li> <li>• Connected load too heavy.</li> <li>• Encoder failure, encoder mechanical joint broken down, disconnection of one of the signal cables of the encoder.</li> </ul>  |
|             | <b>Solution</b>       | <ol style="list-style-type: none"> <li>1. Set parameters <b>C192</b>, <b>C193</b> correctly.</li> <li>2. Check torque limit value (see the INPUTS FOR REFERENCES MENU and the CONTROL METHOD MENU).</li> <li>3. Check the mechanical load.</li> <li>4. Make sure that the encoder works properly, check its mechanical connection to the motor and check that the encoder signal cables are properly connected to the terminals.</li> </ol> |

**A081 Keypad Watchdog**

|             |                       |  |
|-------------|-----------------------|--|
| <b>A081</b> | <b>Description</b>    | Watchdog for the communication to the keypad.  |
|             | <b>Event</b>          | Communication failed when the keypad was enabled as a reference source or a command source or when it was in Local mode (Watchdog time is equal to approx. 1.6 seconds)  |
|             | <b>Possible cause</b> | <ul style="list-style-type: none"> <li>• Keypad cable disconnected.</li> <li>• Failure of one of the two connectors of the keypad.</li> <li>• Strong electromagnetic disturbance or radiated interference.</li> <li>• Keypad failure.</li> <li>• Incorrect setting in parameters relating to serial link 1 (see the SERIAL LINKS MENU).</li> </ul> |
|             | <b>Solution</b>       | <ol style="list-style-type: none"> <li>1. Check the connection of the keypad cable.</li> <li>2. Make sure that the keypad cable connectors are intact (on both drive side and keypad side).</li> <li>3. Check communication parameters of serial link 1.</li> </ol>  |

**A082 Encoder Configuration**

|             |                       |   |
|-------------|-----------------------|---|
| <b>A082</b> | <b>Description</b>    | Functions programmed for <b>MDI6</b> and <b>MDI7</b> , or <b>Encoder B</b> selected and encoder board not detected.   |
|             | <b>Event</b>          | <ul style="list-style-type: none"> <li>• <b>Encoder A</b> has been selected for speed measure or as a reference source, but different digital command functions are programmed for terminals <b>MDI6</b> and <b>MDI7</b>.</li> <li>• <b>Encoder B</b> has been selected for the speed measure or as a reference source, but the control board did not detect any optional encoder board.</li> </ul> |
|             | <b>Possible cause</b> | <ul style="list-style-type: none"> <li>• Incorrect setting of the use of the encoders in parameter <b>C189</b>.</li> <li>• Incorrect programming of digital input functions.</li> <li>• Optional board for Encoder B is not fitted, has been improperly mounted or is faulty. Possible connector failure.</li> </ul>  |
|             | <b>Solution</b>       | <ol style="list-style-type: none"> <li>1. Check and adjust the value set in <b>C189</b> (see the ENCODER/FREQUENCY INPUTS MENU).</li> <li>2. Check and adjust the control function programming for digital inputs <b>MDI6</b> and <b>MDI7</b> (see the DIGITAL INPUTS MENU).</li> <li>3. Check if optional encoder board is fitted and properly mounted.</li> </ol>                                 |

**A083, A084, A085 External Alarm**

|  |                       |   |
|--|-----------------------|---|
| <b>A083 (EXT1)<br/>A084 (EXT2)<br/>A085 (EXT3)</b> | <b>Description</b>    | <b>A083:</b> External alarm 1<br><b>A084:</b> External alarm 2<br><b>A085:</b> External alarm 3   |
|  | <b>Event</b>          | The External Alarm (1, 2, 3) functionality has been programmed, but the relevant digital input is disabled (see the DIGITAL INPUTS MENU). If multiple digital command sources are programmed, alarms <b>A083-A085</b> trip if one of the terminals in the active sources is disabled (see the CONTROL METHOD MENU). |
|  | <b>Possible cause</b> | The cause for the alarm trip does not depend on the drive; check for the reason why the contact connected to terminal <b>MDIx</b> where the External Alarm function is programmed opens.  |
|  | <b>Solution</b>       | Check external signal.  |

**A087 ±15V Loss**

|             |                       |   |
|-------------|-----------------------|---|
| <b>A087</b> | <b>Description</b>    | Loss of ±15V.   |
|             | <b>Event</b>          | <ul style="list-style-type: none"> <li>• The voltage level of ±15V is inadequate.</li> </ul>  |
|             | <b>Possible cause</b> | <ul style="list-style-type: none"> <li>• Possible failure of the control board or other circuits in the Penta Drive.</li> </ul>   |
|             | <b>Solution</b>       | <ol style="list-style-type: none"> <li>1. Reset the alarm: send a <b>RESET</b> command.</li> <li>2. If the alarm persists, please contact ELETTRONICA SANTERNO's Customer Service.</li> </ol> |

**A091 Braking Resistor Overload**

|             |                       |  |
|-------------|-----------------------|--|
| <b>A091</b> | <b>Description</b>    | Overvoltage due to the overload of the braking resistor that has been operating for a time equal to the maximum time due to settings in <b>C211</b> and <b>C212</b> .  |
|             | <b>Event</b>          | The braking resistance command was inhibited because the maximum ON time was expired and the energy caused by regeneration (that can no longer be dissipated) has led to overvoltage.  |
|             | <b>Possible cause</b> | This application requires an intense use of the Braking Resistor, for example in lifting applications, where a long downstroke is required when the load is connected to the motor.  |
|             | <b>Solution</b>       | <ol style="list-style-type: none"> <li>1. Reset the alarm: send a <b>RESET</b> command.</li> <li>2. If the power dissipated by the braking resistance allows for a heavier use, set <b>C211</b> with a greater ON time.</li> </ol> |

**A093 Precharge: Bypass open**

|             |                       |   |
|-------------|-----------------------|---|
| <b>A093</b> | <b>Description</b>    | Bypass relay open.  |
|             | <b>Event</b>          | The control board requested the closure of the bypass relay (or contactor) for the short-circuit of the DC-link capacitor precharge resistors, <b>but no closing signal is sent</b> (auxiliary of the relay) during functioning (precharge already closed). |
|             | <b>Possible cause</b> | Failure in the relay control circuit or in the auxiliary signal circuit detecting relay closing.  |
|             | <b>Solution</b>       | <ol style="list-style-type: none"> <li>1. Reset the alarm: send a <b>RESET</b> command.</li> <li>2. If the alarm persists, please contact ELETTRONICA SANTERNO's Customer Service.</li> </ol>   |

**A094 Heatsink Overheated**

|             |                       |  |
|-------------|-----------------------|--|
| <b>A094</b> | <b>Description</b>    | IGBT heatsink temperature too high.  |
|             | <b>Event</b>          | IGBT power heatsink overheated even if the cooling fan is on (see also <b>A096</b> and <b>A099</b> ).  |
|             | <b>Possible cause</b> | <ul style="list-style-type: none"> <li>• Ambient temperature exceeding 40 °C.</li> <li>• Too high motor current.</li> <li>• Excessive carrier frequency for the application required.</li> </ul> |
|             | <b>Solution</b>       | <ol style="list-style-type: none"> <li>1. Check ambient temperature.</li> <li>2. Check motor current.</li> <li>3. Decrease IGBT carrier frequency (see the CARRIER FREQUENCY MENU).</li> </ol>   |

**A095 Illegal Drive Profile Board**

|             |                       |   |
|-------------|-----------------------|---|
| <b>A095</b> | <b>Description</b>    | An illegal Drive Profile board is implemented.  |
|             | <b>Event</b>          | Incorrect configuration of the optional Drive Profile board.  |
|             | <b>Possible cause</b> | <ul style="list-style-type: none"> <li>• The Drive Profile board is configured for a different drive.</li> <li>• The Drive Profile board is not configured.</li> <li>• Faulty Drive Profile board.</li> </ul> |
|             | <b>Solution</b>       | <ol style="list-style-type: none"> <li>1. Make sure that the Drive Profile board is correctly configured for the Sinus Penta drive.</li> <li>2. Replace the Drive Profile board.</li> </ol>                   |

**A096 Fan Fault**

|             |                       |  |
|-------------|-----------------------|--|
| <b>A096</b> | <b>Description</b>    | Fan alarm.   |
|             | <b>Event</b>          | Power heatsink overheated with fan locked or disconnected or faulty (see also <b>A094</b> and <b>A099</b> ). |
|             | <b>Possible cause</b> | Fan locked or disconnected or faulty.  |
|             | <b>Solution</b>       | Replace fan.   |

**A097 Motor Cables KO**

|             |                       |   |
|-------------|-----------------------|---|
| <b>A097</b> | <b>Description</b>    | Motor not connected.  |
|             | <b>Event</b>          | This protection trips during autotune or DC Brake if the motor is not connected to the drive or if its current value is not compatible with the drive size.   |
|             | <b>Possible cause</b> | <ul style="list-style-type: none"> <li>• One cable of the motor is disconnected.</li> <li>• The motor size is too small if compared to the drive size.</li> </ul>   |
|             | <b>Solution</b>       | <ol style="list-style-type: none"> <li>1. Check that motor cables are properly connected to terminals <b>U, V, W</b>.</li> <li>2. Check the motor parameters; perform autotune procedure again (VTC and FOC controls).</li> </ol> |

**A098 Illegal Motor**

|             |                       |  |
|-------------|-----------------------|--|
| <b>A098</b> | <b>Description</b>    | A disabled motor has been selected.  |
|             | <b>Event</b>          | <ul style="list-style-type: none"> <li>• Motor 2 is enabled, but only one motor can be enabled: <b>C009</b>=1 (see the MOTOR CONFIGURATION MENU).</li> <li>• Motor 3 is enabled, but only 1 or 2 motors can be enabled: <b>C009</b>=1 or 2 (see the MOTOR CONFIGURATION MENU).</li> </ul>  |
|             | <b>Possible cause</b> | <ul style="list-style-type: none"> <li>• Incorrect setting in parameter <b>C009</b>.</li> <li>• Incorrect setting of the digital input parameters enabling the selection functions for motor 2 (<b>C173</b>) and/or motor 3 (<b>C174</b>).</li> </ul>  |
|             | <b>Solution</b>       | <ol style="list-style-type: none"> <li>1. Check and enter the correct value for <b>C009</b>.</li> <li>2. Check and enter the correct value for <b>C173, C174</b>.</li> <li>3. Check the status of the digital commands for terminals <b>C173</b> and <b>C174</b>. If remote command sources are selected, check the status of the commands that have been sent.</li> </ol> |

**A099 Sensor 2 Fault**

|             |                       |   |
|-------------|-----------------------|---|
| <b>A099</b> | <b>Description</b>    | Sensor 2 fault.   |
|             | <b>Event</b>          | Power heatsink overheated with cooling fan off (see also <b>A094</b> and <b>A096</b> ). |
|             | <b>Possible cause</b> | Failure in temperature control device and/or cooling system.                            |
|             | <b>Solution</b>       | Please contact ELETTRONICA SANTERNO's Customer Service.                                 |

**A100 MDI6 Illegal Configuration**

|             |                       |   |
|-------------|-----------------------|---|
| <b>A100</b> | <b>Description</b>    | Function programmed to <b>MDI6</b> and <b>frequency input A</b> as well.  |
|             | <b>Event</b>          | <b>MDI6</b> terminal is programmed with a digital function command and as frequency input <b>A</b> .  |
|             | <b>Possible cause</b> | Incorrect programming of a command function for <b>MDI6</b> , because frequency input A is already set in parameter <b>C189</b> (FinA) (see the DIGITAL INPUTS MENU and the ENCODER/FREQUENCY INPUTS MENU). |
|             | <b>Solution</b>       | Check and adjust programming of the digital input functions and of parameter <b>C189</b> .  |

**A101 MDI8 Illegal Configuration**

|             |                       |   |
|-------------|-----------------------|---|
| <b>A101</b> | <b>Description</b>    | Function programmed to <b>MDI8</b> and <b>frequency input B</b> as well.  |
|             | <b>Event</b>          | <b>MDI8</b> terminal is programmed with a digital function command and as frequency input <b>B</b> .  |
|             | <b>Possible cause</b> | Incorrect programming of a command function for <b>MDI8</b> , because frequency input B is already set in parameter <b>C189</b> (FinB) (see the DIGITAL INPUTS MENU and the ENCODER/FREQUENCY INPUTS MENU). |
|             | <b>Solution</b>       | Check and adjust programming of the digital input functions and of parameter <b>C189</b> .  |

**A102, A103, A104, A086 Current input > 20 mA**

|  |                       |  |
|--|-----------------------|--|
| <b>A102 (REF)<br/>A103 (AIN1)<br/>A104 (AIN2)<br/>A086 (XAIN5)</b> | <b>Description</b>    | <b>A102:</b> REF Current input (4÷20mA or 0÷20mA) greater than 20mA<br><b>A103:</b> AIN1 Current input (4÷20mA or 0÷20mA) greater than 20mA<br><b>A104:</b> AIN2 Current input (4÷20mA or 0÷20mA) greater than 20mA<br><b>A086:</b> XAIN5 Current input (4÷20mA or 0÷20mA) greater than 20mA |
|  | <b>Event</b>          | A current value greater than 20mA has been detected over one input (REF, AIN1, AIN2, XAIN5) set with the following ranges: 4÷20mA or 0÷20mA.   |
|  | <b>Possible cause</b> | <ul style="list-style-type: none"> <li>• Wrong setting of <b>SW1</b> on the control board (except for <b>A086</b>).</li> <li>• Failure in the current signal source.</li> </ul>  |
|  | <b>Solution</b>       | <ol style="list-style-type: none"> <li>1. Check setting of SW1(except for <b>A086</b>).</li> <li>2. Check the current signal source.</li> </ol>  |

**A105, A106, A107, A108 PT100 Channel 1,2,3,4 Fault**

|  |                       |  |
|--|-----------------------|--|
| <b>A105 (Channel 1)<br/>A106 (Channel 2)<br/>A107 (Channel 3)<br/>A108 (Channel 4)</b> | <b>Description</b>    | <b>A105:</b> PT100 Channel 1 fault<br><b>A106:</b> PT100 Channel 2 fault<br><b>A107:</b> PT100 Channel 3 fault<br><b>A108:</b> PT100 Channel 4 fault             |
|  | <b>Event</b>          | Hardware input out of the measure range of the drive.  |
|  | <b>Possible cause</b> | <ul style="list-style-type: none"> <li>• Wrong setting of SW1 or SW2 on optional control board ES847</li> <li>• Failure in the current signal source.</li> </ul> |
|  | <b>Solution</b>       | <ol style="list-style-type: none"> <li>1. Check setting of SW1 and SW2.</li> <li>2. Check the current signal source.</li> </ol>                                  |

**A109 Ambient Overtemperature**

|             |                       |  |
|-------------|-----------------------|--|
| <b>A109</b> | <b>Description</b>    | The ambient temperature is too high.   |
|             | <b>Event</b>          | The control board has detected a too high ambient temperature.   |
|             | <b>Possible cause</b> | Inverter or cabinet overheated; failure of control board NTC.  |
|             | <b>Solution</b>       | <ol style="list-style-type: none"> <li>1. Open the cabinet and check its conditions. Also check measure <b>M062</b>.</li> <li>2. Reset the alarm: send a <b>RESET</b> command.</li> <li>3. If the alarm persists, please contact ELETTRONICA SANTERNO's Customer Service.</li> </ol> |

**A129 No Output Phase**

|             |                       |  |
|-------------|-----------------------|--|
| <b>A129</b> | <b>Description</b>    | Output phase loss  |
|             | <b>Event</b>          | The output current from one of phases U, V, W is close to zero, while the other phases are properly operating.<br>Output phase loss is detected only if: <ul style="list-style-type: none"> <li>• IFD control is selected (<b>C010=0</b>)</li> <li>• Output power exceeds 1Hz</li> <li>• Parameter <b>C225</b> is set greater than 0.</li> </ul> |
|             | <b>Possible cause</b> | One or multiple links to the motor (phases U, V, W) disconnected.  |
|             | <b>Solution</b>       | <ol style="list-style-type: none"> <li>1. Check continuity between the drive and the motor.</li> <li>2. If the alarm persists, please contact ELETTRONICA SANTERNO's Customer Service.</li> </ol>  |

**A140 Torque Off not Safe**

|             |                       |  |
|-------------|-----------------------|--|
| <b>A140</b> | <b>Description</b>    | Malfunctioning of <b>ENABLE-A</b> and <b>ENABLE-B</b> inputs for the STO function  |
|             | <b>Event</b>          | The redundant circuitry for the drive enable (simultaneous activation of the <b>ENABLE-A</b> and <b>ENABLE-B</b> inputs) is no longer active, so opening those inputs does not guarantee that the STO function is properly implemented.<br>For more details, please consult the Safe Torque Off Function - Application Manual. |
|             | <b>Possible cause</b> | Fault in the circuitry dedicated to the Safe Torque Off function.  |
|             | <b>Solution</b>       | <ol style="list-style-type: none"> <li>1. Reset the alarm: send a <b>RESET</b> command.</li> <li>2. If the alarm persists, please contact ELETTRONICA SANTERNO's Customer Service.</li> </ol>  |

## 58.4. List of the DRIVECOM Alarm Codes

If a PROFIdrive expansion board is used (see PROFIDRIVE BOARD CONFIGURATION MENU), the Sinus Penta fault codes are also coded according to the DRIVECOM communication profile.

The specific code is readable @ address 947 of the specific PROFIDRIVE PARAMETERS (see PROFIdrive COMMUNICATIONS BOARD USER MANUAL).

The DRIVECOM User Group e.V. is an association of international [drive manufacturers, universities, and institutes](#). It has set itself a goal to develop a simple integration of drives in open automation systems. The DRIVECOM User Group therefore decided to standardise the communication interface for accessing drives.

Also visit [www.drivecom.org](http://www.drivecom.org).

Table 129: List of the DRIVECOM alarm codes

| Code | Meaning                                | Sinus Penta Fault      | #    |
|------|--|------------------------|------|
| 0000 | <b>No malfunction</b>                  | -                      | A000 |
| 1000 | <b>General malfunction</b>             | NoCurrent Fault        | A060 |
|      |  | AutoTune Fault         | A065 |
|      |  | No Output Phase        | A129 |
| 2000 | <b>Current</b>                         |                        |      |
| 2300 | Current on device output side          |                        |      |
| 2310 | Continuous overcurrent                 |                        |      |
| 2311 | Continuous overcurrent No. 1           | SW OverCurrent         | A044 |
| 2312 | Continuous overcurrent No. 2           | PWMA1 Fault            | A051 |
| 2320 | Short circuit / earth leakage          | PWMA Fault             | A041 |
|      |  | PWMA0 Fault            | A050 |
|      |  | PWMA Not ON            | A053 |
| 3000 | <b>Voltage</b>                         |                        |      |
| 3100 | Mains voltage                          |                        |      |
| 3130 | Phase failure                          | Mains Loss             | A064 |
| 3200 | Internal voltage                       |                        |      |
| 3210 | Internal overvoltage                   | OverVoltage            | A048 |
| 3220 | Internal undervoltage                  | UnderVoltage           | A047 |
| 4000 | <b>Temperature</b>                     | PT100 Channel 1 Fault  | A105 |
|      |  | PT100 Channel 2 Fault  | A106 |
|      |  | PT100 Channel 3 Fault  | A107 |
|      |  | PT100 Channel 4 Fault  | A108 |
| 4100 | Ambient                                |                        |      |
| 4110 | Excess ambient temperature             | Amb.Overtemp.          | A109 |
| 4300 | Drive temperature                      |                        |      |
| 4310 | Excess drive temperature               | Drive OverHeated       | A074 |
|      |  | HeatSink Overheated    | A094 |
| 5000 | <b>Device hardware</b>                 |                        |      |
| 5111 | U1 = supply +/- 15 V                   | ±15V Loss              | A087 |
| 5200 | Control                                | Torque Off Not Safe    | A140 |
| 5210 | Measurement control                    | ADC Not Tuned          | A088 |
| 5220 | Computing circuit                      |                        |      |
| 5300 | Operating unit                         | Parm Lost Chk          | A072 |
|      |  | Parm Lost COM1         | A073 |
|      |  | MMI Trouble            | A078 |
|      |  | KeyPad WatchDog        | A081 |
|      |  | Parm Lost COM2         | A089 |
|      |  | Parm Lost COM3         | A090 |
| 5400 | Power section                          | Fan Fault              | A096 |
|      |  | 2nd Sensor Fault       | A099 |
| 5440 | Contactors                             |                        |      |
| 5441 | Contactactor 1 = manufacturer specific | Bypass Circuit Fault   | A045 |
| 5442 | Contactactor 2 = manufacturer specific | Bypass Connector Fault | A046 |
| 5443 | Contactactor 3 = manufacturer specific | Bypass Circuit Open    | A093 |
| 5500 | Data storage                           |                        |      |
| 5510 | RAM                                    | RAM Fault              | A049 |

| Code | Meaning                      | Sinus Penta Fault           | #    |
|------|------------------------------|-----------------------------|------|
| 6000 | <b>Device software</b>       |                             |      |
| 6010 | Software reset (Watchdog)    |                             |      |
| 6100 | Internal software            | False Interrupt             | A043 |
|      |                              | Generic Motorola            | A063 |
|      |                              | 1ms Interrupt OverTime      | A071 |
| 6200 | User software                | User Fault                  | A040 |
| 6300 | Data record                  |                             |      |
| 6301 | Data record No. 1            | SW Version KO               | A092 |
| 6302 | Data record No. 2            | Optional Board not in       | A054 |
| 6303 | Data record No. 3            | Illegal XMDI in DGI         | A042 |
| 6304 | Data record No. 4            | Illegal XMDI in DGO         | A052 |
| 6305 | Data record No. 5            | Illegal XMDI in MPL         | A057 |
| 6306 | Data record No. 6            | FOC No Encoder              | A079 |
| 6307 | Data record No. 7            | Illegal Encoder Cfg         | A082 |
| 6308 | Data record No. 8            | Illegal Motor Selected      | A098 |
| 6309 | Data record No. 9            | MDI6 Illegal Configuration  | A100 |
| 630A | Data record No. 10           | MDI8 Illegal Configuration  | A101 |
| 7000 | <b>Supplementary modules</b> |                             |      |
| 7100 | Power                        |                             |      |
| 7110 | Brake chopper                | Braking Resistor Overload   | A091 |
| 7120 | Motor                        | Motor Not Connected         | A097 |
| 7300 | Sensor                       | PTC Alarm                   | A055 |
|      |                              | PTC Short Circuit           | A056 |
|      |                              | REF < 4mA                   | A066 |
|      |                              | AIN1 < 4mA                  | A067 |
|      |                              | AIN2 < 4mA                  | A068 |
|      |                              | XAIN5 < 4mA                 | A069 |
|      |                              | REF > 20mA                  | A102 |
|      |                              | AIN1 > 20mA                 | A103 |
|      |                              | AIN2 > 20mA                 | A104 |
|      |                              | XAIN5 > 20mA                | A086 |
| 7301 | Tacho fault                  |                             |      |
|      |                              | Tracking Error              | A080 |
|      |                              | Encoder Fault               | A059 |
|      |                              | ABS Encoder Fault           | A131 |
| 7310 | Speed                        | Speed Alarm                 | A076 |
| 7500 | Communication                | Ser WatchDog                | A061 |
|      |                              | SR1 WatchDog                | A062 |
|      |                              | Fbs WatchDog                | A070 |
|      |                              | Illegal Drive Profile Board | A095 |
| 8000 | <b>Monitoring</b>            |                             |      |
| 8300 | Torque control               |                             |      |
| 8311 | Excess torque                | Motor OverHeated            | A075 |
| 9000 | <b>External malfunction</b>  | External Alarm 1            | A083 |
|      |                              | External Alarm 2            | A084 |
|      |                              | External Alarm 3            | A085 |

## 58.5. Warnings

---

**Warning** messages are displayed on the display/keypad. They are flashing messages that usually appear in line 1 or 2 of the first three lines of the display.



**NOTE** Warnings are neither protections nor alarms, and are not stored to the fault list.

Some warnings simply state what's happening or suggest what to do when using the keypad. However, most of the warning messages are **Coded warnings**: they are displayed with letter **“W”** followed by two **digits** stating which warning is active at that moment. Example:

|   |   |   |   |   |   |   |   |   |   |   |   |   |
|---|---|---|---|---|---|---|---|---|---|---|---|---|
| W | 3 | 2 | O | P | E | N | E | N | A | B | L | E |
|---|---|---|---|---|---|---|---|---|---|---|---|---|

Warning messages are detailed in the following section.

## 58.6. Warning List

Table 130: Warning list

| Warning | Alarm Message      | Description   |
|---------|--------------------|---|
| W03     | SEARCHING...       | The user interface is searching the data of the next page to display.   |
| W04     | DATA READ KO       | Software warnings concerning data reading.  |
| W06     | HOME SAVED         | The page displayed has been saved as the home page displayed at power on.   |
| W07     | DOWNLOADING        | The keypad is <b>writing</b> to the drive the WORK zone parameters saved on its own flash memory.   |
| W08     | UPLOADING          | The keypad is <b>reading</b> from the drive the WORK zone parameters that will be saved on its own flash memory.  |
| W09     | DOWNLOAD OK        | Parameters were successfully downloaded ( <b>written</b> ) from the keypad to the drive.  |
| W11     | UPLOAD OK          | Parameters were successfully uploaded ( <b>read</b> ) from the drive to the keypad.   |
| W12     | UPLOAD KO          | The keypad interrupted parameter upload to the drive.<br>Parameter <b>reading</b> has failed.   |
| W13     | NO DOWNLOAD        | A Download procedure was queried, but no parameter is saved to the flash memory.  |
| W16     | PLEASE WAIT...     | Wait until the system completes the operation required.   |
| W17     | SAVE IMPOSSIBLE    | Parameter save is not allowed.  |
| W18     | PARAMETERS LOST    | The keypad interrupted parameter download to the drive. Parameter <b>writing</b> has failed. As a result, not all parameters have been updated (parameter inconsistency).   |
| W19     | NO PARAMETERS LOAD | UPLOAD impossible.  |
| W20     | NOT NOW            | The required function is not available at the moment.   |
| W21     | CONTROL ON         | The required function is inhibited because the drive is running: <b>ENABLE-A</b> and <b>ENABLE-B</b> are active.  |
| W23     | DOWNLOAD VER. KO   | Download failed because parameters saved to keypad memory relate to a SW version or product ID incompatible with the drive SW version or product ID.  |
| W24     | VERIFY DATA        | Download preliminary operation underway, the system is checking the integrity and compatibility of the parameters saved in the keypad memory.   |
| W28     | OPEN START         | Open and close the <b>START</b> signal to start the drive.  |
| W31     | ENCODER OK         | Encoder tuning procedure finished: the encoder is correctly connected.  |
| W32     | OPEN ENABLE        | Open and close the <b>ENABLE-A</b> and <b>ENABLE-B</b> signals to enable the drive.   |
| W33     | WRITE IMPOSSIBLE   | Writing procedure impossible.   |
| W34     | ILLEGAL DATA       | Illegal value entered, operation failed.  |
| W35     | NO WRITE CONTROL   | Writing procedure impossible because Control is active and the drive is running.  |
| W36     | ILLEGAL ADDRESS    | Illegal address entered, operation failed.  |
| W37     | ENABLE LOCKED      | The drive is disabled and does not acknowledge the <b>ENABLE-A</b> and <b>ENABLE-B</b> commands because it is writing a <b>Cxxx</b> parameter.<br> <b>CAUTION: The drive will start up as soon as writing is over!!!</b> |
| W38     | LOCKED             | Editing mode cannot be accessed because parameter modification is disabled: <b>P000</b> is different from <b>P002</b> .   |
| W39     | KEYPAD DISABLED    | Editing mode cannot be accessed because the keypad is disabled.   |
| W40     | FAN FAULT          | Fan locked or disconnected or faulty.   |
| W41     | SW VERSION KO      | Download impossible because of different SW Versions.   |
| W42     | IDP KO             | Download impossible because of different IDPs (Identification Products).  |
| W43     | PIN KO             | Download impossible because of different PINs (Part Identification Numbers).  |
| W44     | CURRENT CLASS KO   | Download impossible because of different current classes.   |
| W45     | VOLTAGE CLASS KO   | Download impossible because of different voltage classes.   |
| W46     | DOWNLOAD KO        | Download impossible (generic cause).  |
| W48     | OT Time over       | The preset threshold for the drive Operation Time has been exceeded.  |
| W49     | ST Time over       | The preset threshold for the drive Supply Time has been exceeded.   |
| W50     | NTC Fault          | NTC sensor for heatsink temperature disconnected or faulty.   |

## 58.7. State List

Table 131: State list

| Number | State              | Description  |
|--------|--------------------|--|
| 0      | ALARM!!!           | Alarm tripped  |
| 1      | STARTING UP        | The drive is starting up   |
| 2      | MAINS LOSS         | Mains loss   |
| 3      | TUNING             | The drive is tuning  |
| 4      | SPEED SEARCHING    | Searching for motor speed  |
| 5      | DCB at START       | DC Braking at start  |
| 6      | DCB at STOP        | DC Braking at stop   |
| 7      | DCB HOLD           | DC current for Hold function   |
| 8      | MANUAL DCB         | Manual DC Braking  |
| 9      | LIMIT WHILE ACCEL. | Current/torque limit while accelerating  |
| 10     | LIMIT WHILE DECEL. | Current/torque limit while decelerating  |
| 11     | LIMIT AT ST. SPD   | Current/torque limit at constant rpm   |
| 12     | BRAKING            | Braking module startup or deceleration ramp extension  |
| 13     | RUN AT ST. SPEED   | Drive running at speed set point   |
| 14     | ACCELERATING       | Drive running with motor in acceleration stage   |
| 15     | DECELERATING       | Drive running with motor in deceleration stage   |
| 16     | INVERTER OK        | Drive on Stand-by with no alarms tripped   |
| 17     | FLUXING            | Motor fluxing stage  |
| 18     | FLUXED MOTOR       | Motor fluxed   |
| 19     | FIRE MODE RUN      | Constant rpm in Fire Mode  |
| 20     | FIRE MODE ACC.     | Acceleration in Fire Mode  |
| 21     | FIRE MODE DEC.     | Deceleration in Fire Mode  |
| 22     | INVERTER OK*       | Drive on Stand-by with no alarms tripped;<br>void warranty due to alarm trip in Fire Mode  |
| 25     | SPARE              | Board in Spare mode  |
| 27     | WAIT NO ENABLE     | Waiting for opening <b>ENABLE-A</b> and <b>ENABLE-B</b> commands   |
| 28     | WAIT NO START      | Waiting for opening <b>START</b> command   |
| 29     | PIDOUT min DISAB   | Drive disabled due to PID output < Min.  |
| 30     | REF min DISABLED   | Drive disabled due to REF < Min.   |
| 31     | IFD WAIT REF.      | Drive enabled with IFD control<br>waiting for reference in order to start  |
| 32     | IFD WAIT START     | Drive enabled with IFD control<br>waiting for <b>START</b> in order to start   |
| 33     | DISABLE NO START   | When fluxing, the RUN command was not given within the max. time set in <b>C183</b> . The drive is kept disabled until the RUN command is given. |

## 59. CUSTOM PARAMETERS

In the table below, you can write down settings that are different from the default values.

| PAR.-Meaning                       | Default values | Modified values | PAR.-Meaning                          | Default Values      | Modified values |
|------------------------------------|----------------|-----------------|---------------------------------------|---------------------|-----------------|
| <b>P00x Access Level</b>           |                |                 |                                       |                     |                 |
| P001-AcsLev                        | 0: Basic       |                 | P003-ModCmode                         | 1:[StandBy+Fluxing] |                 |
| <b>Product</b>                     |                |                 |                                       |                     |                 |
| P263-Lang                          | 1: ENGLISH     |                 |                                       |                     |                 |
| <b>P26x Display</b>                |                |                 |                                       |                     |                 |
| P264-ModNav                        | 0: Menu        |                 | P264a-ModNavMenu                      | 1: Yes              |                 |
| P264b-ModMenu                      | 0: Standard    |                 | P265-FirstPage                        | 3: [Start Up]       |                 |
| P266-kpd_type                      | 1: Active Ref. |                 | P267-umis1_PID                        | 0: Disable          |                 |
| P267a- Custom PID unit of measures | [%]            |                 |                                       |                     |                 |
| P268-Measure n.1 Status Page       | M004           |                 | P268y-Scaling Measure n.1 Status Page | 100.00%             |                 |
| P268a-Measure n.2 Status Page      | M000           |                 | P268z-Scaling Measure n.2 Status Page | 100.00%             |                 |
| P268b-Measure n.1 Keypad Page      | M006           |                 | P268c-Measure n.2 Keypad Page         | M026                |                 |
| P268d-Measure n.3 Keypad Page      | M004           |                 | P268e-Measure n.4 Keypad Page         | M000                |                 |
| P269-DisabKey1                     | 0: No          |                 | P269a-DisabKey2                       | 0: No               |                 |
| P269b-EscKeyFunc                   | 0: No          |                 |                                       |                     |                 |
| <b>P00x-P03x Ramps</b>             |                |                 |                                       |                     |                 |
| P009-Tup1                          | [*]            |                 | P010-Tdn1                             | [*]                 |                 |
| P012-Tup2                          | [*]            |                 | P013-Tdn2                             | [*]                 |                 |
| P014-Un.Meas1-2                    | [*]            |                 | P015-Tup3                             | [*]                 |                 |
| P016-Tdn3                          | [*]            |                 | P018-Tup4                             | [*]                 |                 |
| P019-Tdn4                          | [*]            |                 | P020-Un.Meas3-4                       | [*]                 |                 |
| P021a-Rnd.Sel1                     | 1: On          |                 | P021b-Rnd.Sel2                        | 1: On               |                 |
| P021c-Rnd.Sel3                     | 1: On          |                 | P021d-Rnd.Sel4                        | 1: On               |                 |
| P022-RndStartAcc                   | [*]            |                 | P023-RndStopAcc.                      | [*]                 |                 |
| P024-RndStartDec                   | [*]            |                 | P025-RndStopDec                       | [*]                 |                 |
| P026-T Tup                         | 5.00 s         |                 | P027-T Tdn                            | 5.00 s              |                 |
| P028-T Un.Mea                      | 1: 0.1 s       |                 | P029-J Tup                            | 1 s                 |                 |
| P030-J Tdn                         | 1 s            |                 | P031-SpdAccReset                      | 1: Yes              |                 |
| P032-TupFireM                      | [*]            |                 | P033-TdnFireM                         | [*]                 |                 |
| <b>P05x-P07x Reference</b>         |                |                 |                                       |                     |                 |
| P050-REF                           | 3: 0-10V       |                 | P051-REFMIN                           | 0.0 V               |                 |
| P051a-REFMIN_%                     | 100%           |                 | P052-REFMAX                           | 10.0 V              |                 |
| P052a-REFMAX_%                     | 100%           |                 | P053-REFOFFS                          | 0.000 V             |                 |
| P054-TauFilt REF                   | 5 ms           |                 | P055-AIN1                             | 2: 4-20mA           |                 |
| P056-AIN1MIN                       | 4.0 mA         |                 | P056a-AIN1MIN_%                       | 100%                |                 |
| P057-AIN1MAX                       | 20.0 mA        |                 | P057a-AIN1MAX_%                       | 100%                |                 |
| P058-AIN1OFFS                      | 0.000 mA       |                 | P059-TauFilt AIN1                     | 5 ms                |                 |
| P060-AIN2                          | 2: 4-20mA      |                 | P061-AIN2MIN                          | 4.0 mA              |                 |
| P061a-AIN2MIN_%                    | 100%           |                 | P062-AIN2MAX                          | 20.0 mA             |                 |
| P062a-AIN2MAX_%                    | 100%           |                 | P063-AIN2OFFS                         | 0.000 mA            |                 |
| P064-TauFilt AIN2                  | 5 ms           |                 | P065-SpdDisab                         | 0 rpm               |                 |
| P066-SpdDisabTime                  | 0 s            |                 | P067-U/D Ramp                         | Square              |                 |
| P068-U/D Mem                       | 1: Yes         |                 | P068a-U/D1-StopRes                    | 0: No               |                 |
| P068b-U/D2-StopRes                 | 0: No          |                 | P068c-U/D1SwSRes                      | 0: No               |                 |
| P068d-U/D2SwSRes                   | 0: No          |                 | P069-U/D Range                        | 1: Unipolar         |                 |
| P070-Jog Ref                       | 0%             |                 | P071-PulseMin                         | 10000 Hz            |                 |
| P071a-PulseMin_%                   | 100%           |                 | P072-PulseMax                         | 100000 Hz           |                 |
| P072a-PulseMax_%                   | 100%           |                 | P073-EncMin                           | 0 rpm               |                 |
| P073a-EncMin_%                     | 100%           |                 | P074-EncMax                           | 1500 rpm            |                 |
| P074a-EncMax_%                     | 100%           |                 |                                       |                     |                 |

| PAR.-Meaning                        | Default values | Modified values | PAR.-Meaning         | Default values | Modified values |
|-------------------------------------|----------------|-----------------|----------------------|----------------|-----------------|
| <b>P08x-P10x Multispeeds</b>        |                |                 |                      |                |                 |
| P080-Mspd.use                       | 0:Preset Speed |                 | P081-Spd1            | 0.00 rpm       |                 |
| P083-Spd2                           | 0.00 rpm       |                 | P085-Spd3            | 0.00 rpm       |                 |
| P087-Spd4                           | 0.00 rpm       |                 | P088-Spd5            | 0.00 rpm       |                 |
| P089-Spd6                           | 0.00 rpm       |                 | P090-Spd7            | 0.00 rpm       |                 |
| P091-Spd8                           | 0.00 rpm       |                 | P092-Spd9            | 0.00 rpm       |                 |
| P093-Spd10                          | 0.00 rpm       |                 | P094-Spd11           | 0.00 rpm       |                 |
| P095-Spd12                          | 0.00 rpm       |                 | P096-Spd13           | 0.00 rpm       |                 |
| P097-Spd14                          | 0.00 rpm       |                 | P098-Spd15           | 0.00 rpm       |                 |
| P099-FireM_Spd                      | 750.00 rpm     |                 | P100-Un.Meas         | 0: 0.01 rpm    |                 |
| <b>P08x-P09x PID Multireference</b> |                |                 |                      |                |                 |
| P080a-Mref.use PID                  | 0:Preset Ref   |                 | P081a-Ref 1 PID      | 0.00           |                 |
| P082a-Ref 2 PID                     | 0.00           |                 | P083a-Ref 3 PID      | 0.00           |                 |
| P084a-Ref 4 PID                     | 0.00           |                 | P085a-Ref 5 PID      | 0.00           |                 |
| P086a-Ref 6 PID                     | 0.00           |                 | P087a-Ref 7 PID      | 0.00           |                 |
| P099a-FireM_Ref PID                 | 0.00           |                 |                      |                |                 |
| <b>P10x Prohibit Speeds</b>         |                |                 |                      |                |                 |
| P105-Velbp1                         | 0 rpm          |                 | P106-Velbp2          | 0 rpm          |                 |
| P107-Velbp3                         | 0 rpm          |                 | P108-Bwbps           | 0 rpm          |                 |
| <b>P11x-P12x % Var. Ref.</b>        |                |                 |                      |                |                 |
| P115-VarPerc1                       | 0.0 %          |                 | P116-VarPerc2        | 0.0 %          |                 |
| P117-VarPerc3                       | 0.0 %          |                 | P118-VarPerc4        | 0.0 %          |                 |
| P119-VarPerc5                       | 0.0 %          |                 | P120-VarPerc6        | 0.0 %          |                 |
| P121-VarPerc7                       | 0.0 %          |                 |                      |                |                 |
| <b>P12x-P15x Speed Loop</b>         |                |                 |                      |                |                 |
| P125-Ti min M1                      | 0.500 s        |                 | P126-Ti max M1       | 0.500 s        |                 |
| P128-Kp min M1                      | 10.00          |                 | P129-Kp max M1       | 10.00          |                 |
| P130-Err.min M1                     | 1.00 %         |                 | P131-Err.max M1      | 1.00 %         |                 |
| P135-Ti min M2                      | 0.500 s        |                 | P136-Ti max M2       | 0.500 s        |                 |
| P138-Kp min M2                      | 10.00          |                 | P139-Kp max M2       | 10.00          |                 |
| P140-Err.min M2                     | 1.00 %         |                 | P141-Err.max M2      | 1.00 %         |                 |
| P145-Ti min M3                      | 0.500 s        |                 | P146-Ti max M3       | 0.500 s        |                 |
| P148-Kp min M3                      | 10.00          |                 | P149-Kp max M3       | 10.00          |                 |
| P150-Err.min M3                     | 1.00 %         |                 | P151-Err.max M3      | 1.00 %         |                 |
| P152-curr_symm.                     | 0 %            |                 | P153-Tauw            | 10 ms          |                 |
| <b>P15x-P17x FOC Regulator</b>      |                |                 |                      |                |                 |
| P155-Curr_Kp M1                     | 3.00           |                 | P156-Curr_Ti M1      | 20.0 ms        |                 |
| P158-Flux_Kp M1                     | 0.00           |                 | P159-Flux_Ti M1      | 33 ms          |                 |
| P162-Curr_Kp M2                     | 3.00           |                 | P163-Curr_Ti M2      | 20.0 ms        |                 |
| P165-Flux_Kp M2                     | 0.00           |                 | P166-Flux_Ti M2      | 33 ms          |                 |
| P169-Curr_Kp M3                     | 3.00           |                 | P170-Curr_Ti M3      | 20.0 ms        |                 |
| P172-Flux_Kp M3                     | 0.00           |                 | P173-Flux_Ti M3      | 33 ms          |                 |
| <b>P175xx VTC Regulator</b>         |                |                 |                      |                |                 |
| P175h1-FluxBoost_M1                 | 0.0 %          |                 | P175i1-BoostThLow_M1 | 10.0 %         |                 |
| P175j1-BoostThHigh_M1               | 30.0 %         |                 | P175r1-Kp_id_M1      | 800.0          |                 |
| P175s1-Tau_iq_M1                    | [Disabled]     |                 | P175t1-Kp_iq_M1      | 320.0          |                 |
| P175u1-Tau_iq_M1                    | 50 ms          |                 | P175v1-Kpsi_M1       | 50.0           |                 |
| P175h2-FluxBoost_M2                 | 0.0 %          |                 | P175i2-BoostThLow_M2 | 10.0 %         |                 |
| P175j2-BoostThHigh_M2               | 30.0 %         |                 | P175r2-Kp_id_M2      | 800.0          |                 |
| P175s2-Tau_iq_M2                    | [Disabled]     |                 | P175t2-Kp_iq_M2      | 320.0          |                 |
| P175u2-Tau_iq_M2                    | 50 ms          |                 | P175v2-Kpsi_M2       | 50.0           |                 |
| P175h3-FluxBoost_M3                 | 0.0 %          |                 | P175i3-BoostThLow_M3 | 10.0 %         |                 |
| P175j3-BoostThHigh_M3               | 30.0 %         |                 | P175r3-Kp_id_M3      | 800.0          |                 |
| P175s3-Tau_iq_M3                    | [Disabled]     |                 | P175t3-Kp_iq_M3      | 320.0          |                 |
| P175u3-Tau_iq_M3                    | 50 ms          |                 | P175v3-Kpsi_M3       | 50.0           |                 |
| P175k-ExtraFlux                     | 110.0 %        |                 | P175n-i0TMinPerc     | 15.0 %         |                 |
| P175o-TauFluxR                      | 300 ms         |                 | P175p-TauLambda      | 250 ms         |                 |
| P175w-VtcCtrlAtStop                 | Speed          |                 |                      |                |                 |

| PAR.-Meaning                    | Default values | Modified values | PAR.-Meaning      | Default values  | Modified values |
|---------------------------------|----------------|-----------------|-------------------|-----------------|-----------------|
| <b>P17x-P21x Analog Outputs</b> |                |                 |                   |                 |                 |
| P176-AO1 Mode                   | 1: +/-10V      |                 | P177-AO1 Sel      | 1: Motor Speed  |                 |
| P178-AO1 Min                    | -1500.000 rpm  |                 | P179-AO1 Max      | 1500.000 rpm    |                 |
| P180-AO1 Offset                 | 0.000 V        |                 | P181-AO1 Filt     | 0.000 s         |                 |
| P182-AO1 Out_min                | -10.0 V        |                 | P183-AO1 Out_max  | 10.0 V          |                 |
| P184-AO2 Mode                   | 1: +/-10V      |                 | P185-AO2 Sel      | 2: Speed Ref.   |                 |
| P186-AO2 Min                    | -1500.000 rpm  |                 | P187-AO2 Max      | 1500.000 rpm    |                 |
| P188-AO2 Offset                 | 0.000 V        |                 | P189-AO2 Filt     | 0.000 s         |                 |
| P190-AO2 Out_min                | -10.0 V        |                 | P191-AO2 Out_max  | 10.0 V          |                 |
| P192-AO3 Mode                   | 1: +/-10V      |                 | P193-AO3 Sel      | 5:Motor Current |                 |
| P194-AO3 Min                    | 0.000 A        |                 | P195-AO3 Max      | 36.000 A        |                 |
| P196-AO3 Offset                 | 0.000 V        |                 | P197-AO3 Filt     | 0.000 s         |                 |
| P198-AO3 Out_min                | -10.0 V        |                 | P199-AO3 Out_max  | 10.0 V          |                 |
| P200-PulsOut Mode               | 0: Disabled    |                 | P201-PlsOut Sel   | 1: Motor Speed  |                 |
| P202-Pls Out Min                | 0 rpm          |                 | P203-Pls Out Max  | 0 rpm           |                 |
| P204-Pls Out Fmax               | 10.00 kHz      |                 | P205-Pls Out Fmin | 100.00 kHz      |                 |
| P206-Pls Out Filt               | 0.000 s        |                 | P207-AO1Gain      |                 |                 |
| P208-AO2Gain                    |                |                 | P209-AO3Gain      | RESERVED        |                 |
| P210-AO1Address                 | RESERVED       |                 | P211-AO2Address   |                 |                 |
| P212-AO3Address                 |                |                 | P213-Sin Amp      | 100.0 %         |                 |
| P214-Sin Freq                   | 1.00 Hz        |                 | P215-Saw Freq     | 1.000 Hz        |                 |

| PAR.-Meaning                           | Default Values       | Modified values | PAR.-Meaning        | Default Values       | Modified values |
|--|----------------------|-----------------|---------------------|----------------------|-----------------|
| <b>P21x-P22x Timers</b>                |                      |                 |                     |                      |                 |
| P216-T1 delay On                       | 0.0 s                |                 | P217-T1 delay Off   | 0.0 s                |                 |
| P218-T2 delay On                       | 0.0 s                |                 | P219-T2 delay Off   | 0.0 s                |                 |
| P220-T3 delay On                       | 0.0 s                |                 | P221-T3 delay Off   | 0.0 s                |                 |
| P222-T4 delay On                       | 0.0 s                |                 | P223-T4 delay Off   | 0.0 s                |                 |
| P224-T5 delay On                       | 0.0 s                |                 | P225-T5 delay Off   | 0.0 s                |                 |
| P226a-Timer MDI1                       | 0                    |                 | P226b-Timer MDI2    | 0                    |                 |
| P226c-Timer MDI3                       | 0                    |                 | P226d-Timer MDI4    | 0                    |                 |
| P227a-Timer MDI5                       | 0                    |                 | P227b-Timer MDI6    | 0                    |                 |
| P227c-Timer MDI7                       | 0                    |                 | P227d-Timer MDI8    | 0                    |                 |
| P228a-Timer MDO1                       | 0                    |                 | P228b-Timer MDO2    | 0                    |                 |
| P228c-Timer MDO3                       | 0                    |                 | P228d-Timer MDO4    | 0                    |                 |
| P229a-Timer MPL1                       | 0                    |                 | P229b-Timer MPL2    | 0                    |                 |
| P229c-Timer MPL3                       | 0                    |                 | P229d-Timer MPL4    | 0                    |                 |
| <b>P23x VTC DEAD-TIME compensation</b> |                      |                 |                     |                      |                 |
| P230-DTcompSel                         | 2: compensation 2    |                 | P231-lthPosDTc      | [*]                  |                 |
| P232-lthNegDTc                         | [*]                  |                 | P233-DtPosDTc       | [*]                  |                 |
| P234-DtNegDTc                          | [*]                  |                 |                     |                      |                 |
| <b>P23x-P26x PID Parameters</b>        |                      |                 |                     |                      |                 |
| P236-PID Out Max                       | 100.00 %             |                 | P237-PID Out Min    | 100.00 %             |                 |
| P237a-Wake Up Mode                     | 0: Disabled          |                 | P237b-Wake Up Level | 0.00 %               |                 |
| P238-Integ Max                         | 100.00 %             |                 | P239-Der Max        | 100.00 %             |                 |
| P240-PID Kp                            | 1.000                |                 | P241-PID KpMult     | 0: 1                 |                 |
| P242-PID Ti(Tc)                        | 500 Tc               |                 | P243-PID Td(Tc)     | 0 mTc                |                 |
| P244-PID Tc                            | 5 ms                 |                 | P245-PID Ref Min    | 0.00 %               |                 |
| P246-PID Ref Max                       | 100.00 %             |                 | P247-PID Fdbk Min   | 0.00 %               |                 |
| P248-PID Fdbk Max                      | 100.00 %             |                 | P249-PID Tup        | 0.00 s               |                 |
| P250-PID Tdn                           | 0.00 s               |                 | P251-PID U.Mea.     | 1: 0.1 s             |                 |
| P252-Rnd start                         | 50 %                 |                 | P253-Rnd stop       | 50 %                 |                 |
| P254-Thresh Int                        | 0.0 % Refmax         |                 | P255-Disab Time     | Disabled             |                 |
| P256-Trate Lim                         | 1 ms                 |                 | P257-GainScale      | 1.000                |                 |
| P260-GainAWUP                          | 1.00                 |                 |                     |                      |                 |
| <b>P27x-P30x Digital Outputs</b>       |                      |                 |                     |                      |                 |
| P270-Out1Mode                          | 3: Analog            |                 | P271-Out1Sel1       | A71: Speed           |                 |
| P272-Out1Sel2                          | A71: Speed           |                 | P273-Out1 Test1     | 0: >                 |                 |
| P274-Out1 Test2                        | 3: ≤                 |                 | P275-D01 ValTst1    | 50.000 rpm           |                 |
| P276-D01 ValTst2                       | 10.000 rpm           |                 | P277-Out1Func       | 1: (A) Set (B) Reset |                 |
| P277a-Out1Sel1                         | D0: Disable          |                 | P277b-Out1Func      | 0: f(A,B) OR (C)     |                 |
| P278-Out1Logic                         | 1: True              |                 | P279-Out2Mode       | 6: Brake             |                 |
| P280-Out2Sel1                          | A81: Torque output   |                 | P281-Out2Sel2       | A71: Speed           |                 |
| P282-Out2 Test1                        | 0: >                 |                 | P283-Out2 Test2     | 3: ≤                 |                 |
| P284-D02 ValTst1                       | 20.000 %             |                 | P285-D02 ValTst2    | 50.000 rpm           |                 |
| P286-Out2Func                          | 1: (A) Set (B) Reset |                 | P286a-Out2Sel1      | D0: Disable          |                 |
| P286b-Out2Func                         | 0: f(A,B) OR (C)     |                 | P287-Out2Logic      | 1: True              |                 |
| P288-Out3Mode                          | 1: Digital           |                 | P289-Out3Sel1       | D3: Inverter Alarm   |                 |
| P290-Out3Sel2                          | D3: Inverter Alarm   |                 | P291-Out3 Test1     | 0: >                 |                 |
| P292-Out3 Test2                        | 0: >                 |                 | P293-D03 ValTst1    | 0.000                |                 |
| P294-D03 ValTst2                       | 0.000                |                 | P295-Out3Func       | 0: (A) OR (B)        |                 |
| P295a-Out3Sel1                         | D0: Disable          |                 | P295b-Out3Func      | 0: f(A,B) OR (C)     |                 |
| P296-Out3Logic                         | 0: False             |                 | P297-Out4Mode       | 1: Digital           |                 |
| P298-Out4Sel1                          | D1: Inverter Run Ok  |                 | P299-Out4Sel2       | D1: Inverter Run Ok  |                 |
| P300-Out4 Test1                        | 0: >                 |                 | P301-Out4 Test2     | 0: >                 |                 |
| P302-D04 ValTst1                       | 0.000                |                 | P303-D04 ValTst2    | 0.000                |                 |
| P304-Out4Func                          | 0: (A) OR (B)        |                 | P304a-Out4Sel1      | D0: Disable          |                 |
| P304b-Out4Func                         | 0: f(A,B) OR (C)     |                 | P305-Out4Logic      | 1: True              |                 |

| PAR.-Meaning                         | Default Values   | Modified values | PAR.-Meaning        | Default Values   | Modified values |
|--------------------------------------|------------------|-----------------|---------------------|------------------|-----------------|
| <b>P306-P317 Aux Digital Outputs</b> |                  |                 |                     |                  |                 |
| P306-Out1Sel                         | D0: Disable      |                 | P307-Out1Logic      | 1: True          |                 |
| P308-Out2Sel                         | D0: Disable      |                 | P309-Out2Logic      | 1: True          |                 |
| P310-Out3Sel                         | D0: Disable      |                 | P311-Out3Logic      | 1: True          |                 |
| P312-Out4Sel                         | D0: Disable      |                 | P313-Out4Logic      | 1: True          |                 |
| P314-Out5Sel                         | D0: Disable      |                 | P315-Out5Logic      | 1: True          |                 |
| P316-Out6Sel                         | D0: Disable      |                 | P317-Out6Logic      | 1: True          |                 |
| <b>P32x PT100 Settings</b>           |                  |                 |                     |                  |                 |
| P320-Mea1 Type                       | 0:Disable        |                 | P321-Offset Mea1    | 0                |                 |
| P322-Mea2 Type                       | 0:Disable        |                 | P323-Offset Mea2    | 0                |                 |
| P324-Mea3 Type                       | 0:Disable        |                 | P325-Offset Mea3    | 0                |                 |
| P326-Mea4 Type                       | 0:Disable        |                 | P327-Offset Mea4    | 0                |                 |
| <b>P33x Fieldbus Parameters</b>      |                  |                 |                     |                  |                 |
| P330-fbs_meas3                       | M012 Torq.Out.%  |                 | P331-fbs_meas4      | M022 PID Out%    |                 |
| <b>P35x-P38x MPL</b>                 |                  |                 |                     |                  |                 |
| P350-Out1Mode                        | 0: Disable       |                 | P351-Out1Sel1       | D0: Disable      |                 |
| P352-Out1Sel2                        | D0: Disable      |                 | P353-Out1 Test1     | 0: >             |                 |
| P354-Out1 Test2                      | 0: >             |                 | P355-D01 ValTst1    | 0                |                 |
| P356-D01 ValTst2                     | 0                |                 | P357-Out1Func       | 0: (A) OR (B)    |                 |
| P357a-Out1Sel1                       | D0: Disable      |                 | P357b-Out1Func      | 0: f(A,B) OR (C) |                 |
| P358-Out1Logic                       | 1: True          |                 | P359-Out2Mode       | 0: Disable       |                 |
| P360-Out2Sel1                        | D0: Disable      |                 | P361-Out2Sel2       | D0: Disable      |                 |
| P362-Out2 Test1                      | 0: >             |                 | P363-Out2 Test2     | 0: >             |                 |
| P364-D02 ValTst1                     | 0                |                 | P365-D02 ValTst2    | 0                |                 |
| P366-Out2Func                        | 0: (A) OR (B)    |                 | P366a-Out2Sel1      | D0: Disable      |                 |
| P366b-Out2Func                       | 0: f(A,B) OR (C) |                 | P367-Out2Logic      | 1: True          |                 |
| P368-Out3Mode                        | 0: Disable       |                 | P369-Out3Sel1       | D0: Disable      |                 |
| P370-Out3Sel2                        | D0: Disable      |                 | P371-Out3 Test1     | 0: >             |                 |
| P372-Out3 Test2                      | 0: >             |                 | P373-D03 ValTst1    | 0                |                 |
| P374-D03 ValTst2                     | 0                |                 | P375-Out3Func       | 0: (A) OR (B)    |                 |
| P375a-Out3Sel1                       | D0: Disable      |                 | P375b-Out3Func      | 0: f(A,B) OR (C) |                 |
| P376-Out3Logic                       | 1: True          |                 | P377-Out4Mode       | 0: Disable       |                 |
| P378-Out4Sel1                        | D0: Disable      |                 | P379-Out4Sel2       | D0: Disable      |                 |
| P380-Out4 Test1                      | 0: >             |                 | P381-Out4 Test2     | 0: >             |                 |
| P382-D04 ValTst1                     | 0                |                 | P383-D04 ValTst2    | 0                |                 |
| P384-Out4Func                        | 0: (A) OR (B)    |                 | P384a-Out4Sel1      | D0: Disable      |                 |
| P384b-Out4Func                       | 0: f(A,B) OR (C) |                 | P385-Out4Logic      | 1: True          |                 |
| <b>P39x Auxiliary Reference</b>      |                  |                 |                     |                  |                 |
| P390-XAIN4                           | 3: 0-10V         |                 | P391-XAIN4MIN       | 0.0 V            |                 |
| P391a-XAIN4MIN %                     | 100%             |                 | P392-XAIN4MAX       | 10.0 V           |                 |
| P392a-XAIN4MAX %                     | 100%             |                 | P393-XAIN4OFFS      | 0.000 V          |                 |
| P394-TauFilt XAIN4                   | 100 ms           |                 | P395-XAIN5          | 2: 4-20mA        |                 |
| P396-XAIN5MIN                        | 4.0 mA           |                 | P396a-XAIN5MIN %    | 100%             |                 |
| P397-XAIN5MAX                        | 20.0 mA          |                 | P397a-XAIN5MAX %    | 100%             |                 |
| P398-XAIN5OFFS                       | 0.000 mA         |                 | P399-TauFilt XAIN5  | 100 ms           |                 |
| <b>P43x-P46x PID2 Parameters</b>     |                  |                 |                     |                  |                 |
| P436-PID2 Out Max                    | 100.00 %         |                 | P437-PID2 Out Min   | 100.00 %         |                 |
| P437a-Wake Up Mode                   | 0: Disabled      |                 | P437b-Wake Up Level | 0.00 %           |                 |
| P438-Integ Max                       | 100.00 %         |                 | P439-Der Max        | 100.00 %         |                 |
| P440-PID2 Kp                         | 1.000            |                 | P441-PID2 KpMult    | 0: 1             |                 |
| P442-PID2 Ti(Tc)                     | 500 Tc           |                 | P443-PID2 Td(Tc)    | 0 mTc            |                 |
| P444-PID2 Tc                         | 5 ms             |                 | P445-PID2 Ref Min   | 0.00 %           |                 |
| P446-PID2 Ref Max                    | 100.00 %         |                 | P447-PID2 Fdbk Min  | 0.00 %           |                 |
| P448-PID2 Fdbk Max                   | 100.00 %         |                 | P449-PID2 Tup       | 0.00 s           |                 |
| P450-PID2 Tdn                        | 0.00 s           |                 | P451-PID2 U.Mea.    | 1: 0.1 s         |                 |
| P452-Rnd start                       | 50 %             |                 | P453-Rnd stop       | 50 %             |                 |
| P454-Thresh Int                      | 0.0 % Refmax     |                 | P455-Disab Time     | Disabled         |                 |
| P456-Trate Lim                       | 1 ms             |                 | P457-GainScale      | 1.000            |                 |
| P460-GainAWUP                        | 1.00             |                 |                     |                  |                 |

| PAR.-Meaning                      | Default values | Modified values | PAR.-Meaning           | Default values | Modified values |
|-----------------------------------|----------------|-----------------|------------------------|----------------|-----------------|
| <b>C00x-C00x Carrier Freq</b>     |                |                 |                        |                |                 |
| C001-Minimun Carrier              | [*]            |                 | C002-Maximum Carrier   | [*]            |                 |
| C003- Pulse Number                | 1: 24          |                 | C004-Silent Modulation | [*]            |                 |
| <b>C00x-C04x Motor Control M1</b> |                |                 |                        |                |                 |
| C008-VmainsNom                    | [**]           |                 | C009-Mot.Numb.         | 1              |                 |
| C010-Ctrl.Type M1                 | 0: IFD         |                 | C011-RefMode M1        | 0: Speed       |                 |
| C012-EncEnab M1                   | 0: No          |                 | C013-v_f_mode1         | [*]            |                 |
| C014-Phase Rot. Mot1              | 0: No          |                 | C015-Fmot M1           | 50.0 Hz        |                 |
| C016-n mot M1                     | 1420 rpm       |                 | C017-Pmot M1           | [*]            |                 |
| C018-lmot M1                      | [*]            |                 | C019-Vmot M1           | [**]           |                 |
| C020-P0 M1                        | 0.0 %          |                 | C021-i0 M1             | 0 %            |                 |
| C022-Rstat M1                     | [*]            |                 | C023-Ld M1             | [*]            |                 |
| C024-Lm M1                        | 250.00 mH      |                 | C025-TauRot M1         | 0 ms           |                 |
| C026-vdcFiltM1                    | 0ms            |                 | C028-nmin M1           | 0 rpm          |                 |
| C029-nmax M1                      | 1500 rpm       |                 | C030-spddeflux M1      | 90 %           |                 |
| C031-nsa M1                       | Disabled       |                 | C032-red_Trq1          | 30.0 %         |                 |
| C033-spd_redTrq1                  | 20 %           |                 | C034-Preboost M1       | [*]            |                 |
| C035-Boost0 M1                    | [*]            |                 | C035a- FrqBst0 M1      | 5%             |                 |
| C036-Boost M1                     | [*]            |                 | C037-FrqBst            | [*]            |                 |
| C038-AutoBst                      | [*]            |                 | C039-SlipComp. M1      | Disabled       |                 |
| C040-DV_M1                        | Disabled       |                 | C041-TFLM1             | [*]            |                 |
| C042-Vout Sat M1                  | 100%           |                 |                        |                |                 |
| <b>C04x-C05x Limits M1</b>        |                |                 |                        |                |                 |
| C043-lacclim M1                   | 150%           |                 | C044-Irunlim M1        | 150%           |                 |
| C045-Ideclim M1                   | [*]            |                 | C046-defilimRed M1     | 0: Disabled    |                 |
| C047-Tmin M1                      | 0.0 %          |                 | C048-Tmax M1           | 120%           |                 |
|                                   |                |                 | C050-fRedLimAcc M1     | 0: Enabled     |                 |
| <b>C05x-C08x Motor Control M2</b> |                |                 |                        |                |                 |
| C053-Ctrl.Type M2                 |                | 0: IFD          | C054-RefMode M2        |                | 0: Speed        |
| C055-EncEnab M2                   | 0: No          |                 | C056-v_f_mode2         | [*]            |                 |
| C057-Phase Rot. Mot2              | 0: No          |                 | C058-Fmot M2           | 50.0 Hz        |                 |
| C059-n mot M2                     | 1420 rpm       |                 | C060-Pmot M2           | [*]            |                 |
| C061-lmot M2                      | [*]            |                 | C062-Vmot M2           | [**]           |                 |
| C063-P0 M2                        | 0.0 %          |                 | C064-i0 M2             | 0 %            |                 |
| C065-Rstat M2                     | [*]            |                 | C066-Ld M2             | [*]            |                 |
| C067-Lm M2                        | 250.00 mH      |                 | C068-TauRot M2         | 0 ms           |                 |
| C069-vdcFiltM2                    | 0ms            |                 | C071-nmin M2           | 0 rpm          |                 |
| C072-nmax M2                      | 1500 rpm       |                 | C073-spddeflux M2      | 90 %           |                 |
| C074-nsa M2                       | Disabled       |                 | C075-red_Trq2          | 30.0 %         |                 |
| C076-spd_redTrq2                  | 20 %           |                 | C077-Preboost M2       | [*]            |                 |
| C078-Boost0 M2                    | [*]            |                 | C078a-FrqBst0 M2       | 5%             |                 |
| C079-Boost M2                     | [*]            |                 | C080-FrqBst M2         | [*]            |                 |
| C081-AutoBst                      | [*]            |                 | C082-SlipComp. M2      | Disabled       |                 |
| C083-DV_M2                        | Disabled       |                 | C084-TFLM2             | [*]            |                 |
| C085-Vout Sat M2                  | 100%           |                 |                        |                |                 |
| <b>C08x-C09x Limits M2</b>        |                |                 |                        |                |                 |
| C086-lacclim M2                   | 150%           |                 | C087-Irunlim M2        | 150%           |                 |
| C088-Ideclim M2                   | [*]            |                 | C089-defilimRed M2     | 0: Disabled    |                 |
| C090-Tmin M2                      | 0.0 %          |                 | C091-Tmax M2           | 120%           |                 |
|                                   |                |                 | C093- fRedLimAcc M2    | 0: Enabled     |                 |

| PAR.-Meaning                      | Default Values       | Modified values | PAR.-Meaning           | Default Values           | Modified values |
|-----------------------------------|----------------------|-----------------|------------------------|--------------------------|-----------------|
| <b>C09x-C12x Motor Control M3</b> |                      |                 |                        |                          |                 |
| C096-Ctrl.Type M3                 | 0: IFD               |                 | C097-RefMode M3        | 0: Speed                 |                 |
| C098-EncEnab M3                   | 0: No                |                 | C099-v_f_mode3         | [*]                      |                 |
| C100-Phase Rot. Mot3              | 0: No                |                 | C101-Fmot M3           | 50.0 Hz                  |                 |
| C102-n mot M3                     | 1420 rpm             |                 | C103-Pmot M3           | [*]                      |                 |
| C104-lmot M3                      | [*]                  |                 | C105-Vmot M3           | [**]                     |                 |
| C106-P0 M3                        | 0.0 %                |                 | C107-i0 M3             | 0 %                      |                 |
| C108-Rstat M3                     | [*]                  |                 | C109-Ld M3             | [*]                      |                 |
| C110-Lm M3                        | 250.00 mH            |                 | C111-TauRot M3         | 0 ms                     |                 |
| C112-vdcFiltM3                    | 0ms                  |                 | C114-nmin M3           | 0 rpm                    |                 |
| C115-nmax M3                      | 1500 rpm             |                 | C116-spddeflux M3      | 90 %                     |                 |
| C117-nsa M3                       | Disabled             |                 | C118-red_Trq3          | 30.0 %                   |                 |
| C119-spd_redTrq3                  | 20 %                 |                 | C120-Preboost M3       | [*]                      |                 |
| C121-Boost0 M3                    | [*]                  |                 | C121a-FrqBst0 M3       | 5%                       |                 |
| C122-Boost M3                     | [*]                  |                 | C123-FrqBst M3         | [*]                      |                 |
| C124-AutoBst                      | [*]                  |                 | C125-SlipComp. M3      | Disabled                 |                 |
| C126-DV_M3                        | Disabled             |                 | C127-TFLM3             | [*]                      |                 |
| C128-Vout Sat M3                  | 100%                 |                 |                        |                          |                 |
| <b>C12x-C13x Limits M3</b>        |                      |                 |                        |                          |                 |
| C129-lacclim M3                   | 150%                 |                 | C130-Irunlim M3        | 150%                     |                 |
| C131-Ideclim M3                   | [*]                  |                 | C132-defilimRed M3     | 0: Disabled              |                 |
| C133-Tmin M3                      | 0.0 %                |                 | C134-Tmax M3           | 120%                     |                 |
|                                   |                      |                 | C136- fRedLimAcc M3    | 0: Enabled               |                 |
| <b>C14x Control Method</b>        |                      |                 |                        |                          |                 |
| C140-Sel Comm 1                   | 1: Terminals         |                 | C141-Sel Comm 2        | 1: Terminals             |                 |
| C142-Sel Comm 3                   | 0: Disabled          |                 | C143-Sel InRef 1       | 1: REF                   |                 |
| C144-Sel InRef 2                  | 2: AIN1              |                 | C145-Sel InRef 3       | 0: Disabled              |                 |
| C146-Sel InRef 4                  | 0: Disabled          |                 | C147-Sel T lim         | 0: Disabled              |                 |
| C148-RemLoc_mode                  | 0: StandBy + Fluxing |                 |                        |                          |                 |
| <b>C15x-C18x Digital Inputs</b>   |                      |                 |                        |                          |                 |
| C149-Start                        | 1: MDI1              |                 | C149a-StartB           | 0: None                  |                 |
| C150-Stop                         | 0: None              |                 | C150a-StopB            | 0: None                  |                 |
| C151-Rev                          | 0: None              |                 | C151a-RevB             | 0: None                  |                 |
| C152-Enable SW                    | 0: None              |                 | C153-Disable           | 0: None                  |                 |
| C154-DisabReset                   | 0: No                |                 | C155-Mltsp 0           | 4: MDI4                  |                 |
| C156-Mltsp 1                      | 5: MDI5              |                 | C157-Mltsp 2           | 0: None                  |                 |
| C158-Mltsp 3                      | 0: None              |                 | C159-Cw-CCw            | 8: MDI8                  |                 |
| C160-DCB                          | 0: None              |                 | C161-Up                | 0: None                  |                 |
| C162-Down                         | 0: None              |                 | C163-U/D Reset         | 0: None                  |                 |
| C164-ExtAlrm 1                    | 0: None              |                 | C164a-ExtAlr1Delay     | 0 ms                     |                 |
| C165-ExtAlrm 2                    | 0: None              |                 | C165a-ExtAlr2Delay     | 0 ms                     |                 |
| C166-ExtAlrm 3                    | 0: None              |                 | C166a-ExtAlr3Delay     | 0 ms                     |                 |
| C167-MltRmp 0                     | 0: None              |                 | C168-MltRmp 1          | 0: None                  |                 |
| C169-Jog                          | 0: None              |                 | C170-Master/Slave      | 0: None                  |                 |
| C171-PID disab.                   | 0: None              |                 | C171a-PID sel. control | 0: Disabled              |                 |
| C172-Keypad lock                  | 0: None              |                 | C173-2nd Mot.          | 0: None                  |                 |
| C174-3rd Mot.                     | 0: None              |                 | C175-PercSpd 0         | 0: None                  |                 |
| C176-PercSpd 1                    | 0: None              |                 | C177-PercSpd 2         | 0: None                  |                 |
| C178-PIDud_res                    | 0: None              |                 | C179-SourceSel         | 0: MDI6                  |                 |
| C180-Loc/Rem                      | 0: MDI7              |                 | C180a-Loc/RemType      | 2:<br>Pushbutton+Storage |                 |
| C181-Safe Start                   | 0: Disabled          |                 | C182-MultiProg         | 0: Disabled              |                 |
| C183-Tflux_dis                    | AlwaysON             |                 | C184-StartFlux         | 0: No                    |                 |
| C184a-TrqRedFluxing               | 0: No                |                 | C185-StartFrWheel      | 0: Dec. Ramp             |                 |
| C186-FireMode                     | 0: None              |                 | C187-DisabExtTlim      | 0: None                  |                 |
| C188a-MrefPID 1                   | 0: None              |                 | C188b-MrefPID 2        | 0: None                  |                 |
| C188c-MrefPID 3                   | 0: None              |                 |                        |                          |                 |

| PAR.-Meaning                             | Default Values    | Modified values | PAR.-Meaning              | Default Values  | Modified values |
|--|-------------------|-----------------|---------------------------|-----------------|-----------------|
| <b>C18x-C19x Encoder/Frequency Input</b> |                   |                 |                           |                 |                 |
| C189-UseEnc                              |                   | 0: A / B Unused |                           |                 |                 |
| C191-pulsEncB                            | 1024              |                 | C190-pulsEncA             | 1024            |                 |
| C193-SpdErr                              | 300 rpm           |                 | C192-SpdAlrTime           | 5.00 s          |                 |
| C195-tauFiltFdbk                         | 5.0 ms            |                 | C194-TrackAlrEn           | 1: Enable       |                 |
| C197-nCH ENCA                            | 0: 2Ch. Quad      |                 | C196-tauFiltRef           | 5.0 ms          |                 |
| C199-EncSign                             | 0: Fdbk.NO Ref.NO |                 | C198-nCH ENCB.            | 0: 2Ch. Quad    |                 |
| <b>C21x Braking Unit</b>                 |                   |                 |                           |                 |                 |
| C210-Enab/Spd BrakeOn                    | [*]               |                 | C211-BrakeTon             | 2.00 s          |                 |
| C212-BrkDutyCycle                        | 10 %              |                 | C213-FreqBoost            | 0%              |                 |
| C213a-KpVdcTrqRed                        | 0.020             |                 | C213b-KiVdcTrqRed         | 0.010           |                 |
| C213c-VdcTrqRedOvfxRef                   | 100.0%            |                 | C213d-VdcTrqRedFluxRed    | 0.0%            |                 |
| <b>C21x-C22x DC Braking</b>              |                   |                 |                           |                 |                 |
| C215-Enab dcb stop                       | 0: No             |                 | C216-Enab dcb start       | 0: No           |                 |
| C217-Tdcb stop                           | 0.5 s             |                 | C218-Tdcb start           | 0.5 s           |                 |
| C219-dcb speed                           | 50 rpm            |                 | C219a-TWRamp              | 500 ms          |                 |
| C220-l dcb                               | 100 %             |                 | C220a-TauIDCB             | 300 ms          |                 |
| C220b-KpIDCB                             | 20                |                 | C220c-TauilDCB            | 100 ms          |                 |
| C221-l dcb hold                          | 0 %               |                 | C222-Tdefl M1             | [*]             |                 |
| C223-Tdefl M2                            | [*]               |                 | C224-Tdefl M3             | [*]             |                 |
| <b>C22x-C23x Power Down</b>              |                   |                 |                           |                 |                 |
| C225-pwd type                            | 3: Alarm          |                 | C226-Tpdd                 | 10 ms           |                 |
| C227-Tpddec                              | 20 s              |                 | C228-Pddecboost           | 0.10 %          |                 |
| C229-Pddcder                             | 1                 |                 | C230-Vpddel               | [**]            |                 |
| C231-Kpvdclc                             | 0.050             |                 | C232-Kivdclc              | 0.500s          |                 |
| C234-stopmode                            | 0: Stop           |                 | C235-stoplev              | 0 rpm           |                 |
| <b>C24x Speed Searching</b>              |                   |                 |                           |                 |                 |
| C245-Enab SpdSch                         | 0: No             |                 | C246-tssd                 | 1 s             |                 |
| C247-SpsRate                             | 10 %              |                 | C248-ls                   | 75 %            |                 |
| C249-SpsSpd                              | 0: Last Speed     |                 | C250-SpdSch_En            | 0:Disable       |                 |
| <b>C25x AutoReset</b>                    |                   |                 |                           |                 |                 |
| C255-nPulsRes                            | Disable           |                 | C256-T ResCyc             | 300 s           |                 |
| C257-PowOnRes                            | 0: No             |                 | C258-UvMIStore            | 0: No           |                 |
| <b>C26x-C27x Thermal Protection</b>      |                   |                 |                           |                 |                 |
| C264-FanTemp                             | 50 °C             |                 | C265-ThermProt M1         | 3: Yes B        |                 |
| C266-ThermCurr M1                        | 105 %             |                 | C267-ThermConstM1         | 720s            |                 |
| C268-ThermProt M2                        | 3: Yes B          |                 | C269-ThermCurr M2         | 105 %           |                 |
| C270-ThermConstM2                        | 720s              |                 | C271-ThermProt M3         | 3: Yes B        |                 |
| C272-ThermCurr M3                        | 105 %             |                 | C273-ThermConstM3         | 720s            |                 |
| C274-PTC ThermProt                       | 0:Disable         |                 |                           |                 |                 |
| <b>C27x Maintenance</b>                  |                   |                 |                           |                 |                 |
| C276-Set OP Time                         | 0h                |                 | C276-Set SP Time          | 0h              |                 |
| <b>C28x-C29x PID Configuration</b>       |                   |                 |                           |                 |                 |
| C285-Sel InPID 1                         | 2: AIN1           |                 | C286-Sel InPID 2          | 0: Disabled     |                 |
| C287-Sel InPID 3                         | 0: Disabled       |                 | C288-Sel Fdbk 1 PID       | 3: AIN2/PTC     |                 |
| C289-Sel Fdbk 2 PID                      | 0: Disable        |                 | C290-Sel Fdbk 3 PID       | 0: Disable      |                 |
| C291-PID Mode                            | 0: Disable        |                 | C291a-PID Control mode    | 0: Standard SUM |                 |
| C291b-PID Mode                           | 0: Disable        |                 | C292-Der Mode             | 0: Measure      |                 |
| C293-PID Struct                          | 0: No             |                 | C294-PID Act              | 1: Reference    |                 |
| <b>C30x Crane</b>                        |                   |                 |                           |                 |                 |
| C300-StartTrq ref.pos.                   | 0.0 %             |                 | C301-t_StartTrq ref.pos.  | 0 ms            |                 |
| C300a-StartTrq ref.neg.                  | 0.0 %             |                 | C301a-t_StartTrq ref.neg. | 0 ms            |                 |
| C302-Brk_On                              | 0: None           |                 | C303-Brk_Off_on_track_err | 1: Yes          |                 |

| PAR.-Meaning                 | Default Values | Modified values | PAR.-Meaning        | Default Values | Modified values |
|------------------------------|----------------|-----------------|---------------------|----------------|-----------------|
| <b>C31x Date and Time</b>    |                |                 |                     |                |                 |
| C310-ModWeekday              | 1: Monday      |                 | C311-ModDay         | 1              |                 |
| C312-ModMonth                | 1: January     |                 | C313-ModYear        | 0              |                 |
| C314-ModHour                 | 0              |                 | C315-ModMin         | 0              |                 |
| C316-Modify Date             |                |                 |                     |                |                 |
| <b>C33x-C35x Timed Flags</b> |                |                 |                     |                |                 |
| C330-TFL1: T on h            | 0              |                 | C331-TFL1: T on m   | 0              |                 |
| C332-TFL1: T on s            | 0              |                 | C333-TFL1: T off h  | 0              |                 |
| C334-TFL1: T off m           | 0              |                 | C335-TFL1: T off s  | 0              |                 |
| C336-TFL1: WeekDays          | 0              |                 | C337-TFL2: T on h   | 0              |                 |
| C338-TFL2: T on m            | 0              |                 | C339-TFL2: T on s   | 0              |                 |
| C340-TFL2: T off h           | 0              |                 | C341-TFL2: T off m  | 0              |                 |
| C342-TFL2: T off s           | 0              |                 | C343-TFL2: WeekDays | 0              |                 |
| C344-TFL3: T on h            | 0              |                 | C345-TFL3: T on m   | 0              |                 |
| C346-TFL3: T on s            | 0              |                 | C347-TFL3: T off h  | 0              |                 |
| C348-TFL3: T off m           | 0              |                 | C349-TFL3: T off s  | 0              |                 |
| C350-TFL3: WeekDays          | 0              |                 | C351-TFL4: T on h   | 0              |                 |
| C352-TFL4: T on m            | 0              |                 | C353-TFL4: T on s   | 0              |                 |
| C354-TFL4: T off h           | 0              |                 | C355-TFL4: T off m  | 0              |                 |
| C356-TFL4: T off s           | 0              |                 | C357-TFL4: WeekDays | 0              |                 |

| PAR.-Meaning                         | Default Values          | Modified values | PAR.-Meaning            | Default Values    | Modified values |
|--------------------------------------|-------------------------|-----------------|-------------------------|-------------------|-----------------|
| <b>R00x-R01x Serial Link</b>         |                         |                 |                         |                   |                 |
| R001-com_slaveaddr                   | 1                       |                 | R002-com_answdelay      | 5 ms              |                 |
| R003-sc0_baudrate                    | 38400 bps               |                 | R004-com_4time_delay    | 2 ms              |                 |
| R005-ser_wdg_time                    | 0.0 s                   |                 | R006-parity_sc0         | 1: No, 2 Stop Bit |                 |
| R008-cm1_slaveaddr                   | 1                       |                 | R009-cm1_answdelay      | 5 ms              |                 |
| R010-sc1_baudrate                    | 38400 bps               |                 | R011-cm1_4time_delay    | 2 ms              |                 |
| R012-sr1_wdg_time                    | 0.0 s                   |                 | R013-parity_sc1         | 1: No, 2 Stop Bit |                 |
| <b>R01x Fieldbus Configuration</b>   |                         |                 |                         |                   |                 |
| R016-fbs_wdg_time                    | 0 ms                    |                 | R017a-AO1_fb_sel        | 0: No             |                 |
| R017b-AO2_fb_sel                     | 0: No                   |                 | R017c-AO3_fb_sel        | 0: No             |                 |
| <b>R02x Expansion Board Settings</b> |                         |                 |                         |                   |                 |
| R021-Data Logger Setting             | 1: NO                   |                 | R023- I/O Board setting | 0:None            |                 |
| <b>R02x-R04x PROFIdrive Settings</b> |                         |                 |                         |                   |                 |
| R025-SlaveAddr                       | 1                       |                 | R026-PZD3_O_Addr        | 1: Digital Inputs |                 |
| R027-PZD4_O_Addr                     | 0: not used             |                 | R028-PZD5_O_Addr        | 0: not used       |                 |
| R029-PZD6_O_Addr                     | 0: not used             |                 | R030-PZD7_O_Addr        | 0: not used       |                 |
| R031-PZD8_O_Addr                     | 0: not used             |                 | R032-PZD9_O_Addr        | 0: not used       |                 |
| R033-PZD10_O_Addr                    | 0: not used             |                 | R034-PZD3_I_Addr        | 0: not used       |                 |
| R035-PZD4_I_Addr                     | 0: not used             |                 | R036-PZD5_I_Addr        | 0: not used       |                 |
| R037-PZD6_I_Addr                     | 0: not used             |                 | R038-PZD7_I_Addr        | 0: not used       |                 |
| R039-PZD8_I_Addr                     | 0: not used             |                 | R040-PZD9_I_Addr        | 0: not used       |                 |
| R041-PZD3_I_Addr                     | 0: not used             |                 | R044-DP com.mode        | 0: DP V0          |                 |
| R045-DP sel.                         | 1: VENDOR SPECIFIC<br>1 |                 |                         |                   |                 |
| <b>R05x Daylight Saving Time</b>     |                         |                 |                         |                   |                 |
| R050-DSTOn WDMM                      | 5703                    |                 | R051-DSTOn HHMM         | 200               |                 |
| R052-DSTOff WDMM                     | 5710                    |                 | R053-DSTOff HHMM        | 200               |                 |
| <b>R11x Data Logger</b>              |                         |                 |                         |                   |                 |
| R115-PIN card SIM                    | "0000"                  |                 | R116-Preset Connections | 0: Disable        |                 |

**Key:**

[\*] Parameter depending on the current size.

[\*\*] Parameter depending on the voltage class.

**60. INDEX**

|              |     |
|--------------|-----|
| 2            |     |
| 2-ZONE ..... | 185 |

**A**

|   |                 |
|---|-----------------|
| ALARM CODES LIST .....                          | 438; 456        |
| ALARMS AND WARNINGS .....                       | 436             |
| ALTERNATIVE COMMAND AND REFERENCE SOURCES ..... | 31; 305         |
| ANALOG AND FREQUENCY OUTPUTS .....              | 145             |
| ANTI-WINDUP .....                               | 176             |
| APPLICATION .....                               | 81              |
| AUTORESET .....                                 | 373             |
| AUTOTUNE .....                                  | 42; 44; 48; 255 |
| AUX REFERENCES .....                            | 250             |
| AUXILIARY DIGITAL OUTPUTS .....                 | 217             |

**B**

|                    |     |
|--------------------|-----|
| BRIDGE CRANE ..... | 398 |
|--------------------|-----|

**C**

|  |     |
|--|-----|
| CARRIER FREQUENCY .....                        | 259 |
| CHANGEOVER FROM REMOTE TO LOCAL COMMAND .....  | 311 |
| COMMAND SOURCES .....                          | 301 |
| CONTROL METHOD .....                           | 300 |
| CONTROLLED STOP IN CASE OF POWER FAILURE ..... | 30  |
| CURRENT BALANCING .....                        | 134 |
| CURRENT LOOP .....                             | 49  |
| CW/CCW INPUT .....                             | 327 |

**D**

|   |         |
|---|---------|
| DATA LOGGER .....                                     | 71; 432 |
| DAYLIGHT SAVING TIME .....                            | 430     |
| DC BRAKING .....                                      | 30; 352 |
| DC BRAKING AT START AND NON-CONDENSING FUNCTION ..... | 352     |
| DC BRAKING AT STOP .....                              | 354     |
| DC BRAKING COMMAND SENT FROM TERMINAL BOARD .....     | 355     |
| DCB INPUT .....                                       | 327     |
| DIGITAL INPUTS .....                                  | 312     |
| DIGITAL OUTPUT MODE .....                             | 188     |
| DIGITAL OUTPUTS .....                                 | 187     |
| DIGITAL PID REGULATOR .....                           | 31      |
| DISABLE INPUT .....                                   | 325     |
| DISABLE LOC/REM FWD/REV KEYS .....                    | 91      |
| DISABLE RESET ALARMS ON MDI3 .....                    | 325     |
| DISPLAY/KEYPAD .....                                  | 18      |
| DOWNLOAD/UPLOAD FROM THE KEYPAD .....                 | 25      |
| DRIVECOM .....  | 456     |
| DRY RUN .....   | 233     |

**E**

|  |     |
|--|-----|
| EEPROM .....   | 434 |
| ELECTRICAL SPECIFICATIONS OF THE CONNECTED MOTOR ..... | 264 |
| ENABLE .....   | 315 |
| ENABLE-A AND ENABLE-B .....                            | 2   |
| ENABLE-SW INPUT .....                                  | 324 |
| ENCODER TEST .....                                     | 47  |
| ENCODER TUNE .....                                     | 47  |
| ENCODER/FREQUENCY INPUTS .....                         | 339 |

## EQUIVALENT CIRCUIT OF THE ASYNCHRONOUS

|                             |          |
|-----------------------------|----------|
| MACHINE .....               | 265      |
| ES836 .....                 | 339      |
| ES847 .....                 | 250; 305 |
| ES851 .....                 | 71; 432  |
| ES913 .....                 | 339      |
| EXTERNAL ALARM INPUTS ..... | 328      |
| EXTERNAL TORQUE LIMIT ..... | 37       |

**F**

|                              |         |
|------------------------------|---------|
| FAULT LIST .....             | 75      |
| FEEDBACK                     |         |
| SPEED .....                  | 47      |
| FEEDBACK FROM ENCODER .....  | 38; 343 |
| FIELDBUS .....               | 418     |
| FIRE MODE .....              | 32; 79  |
| FIRE MODE ENABLE INPUT ..... | 337     |
| FIRST STARTUP .....          | 42      |
| FLUXING AT ACTIVATION .....  | 336     |
| FLUXING MAX. TIME .....      | 336     |
| FOC .....                    | 47; 263 |
| FOC CURRENT REGULATOR .....  | 139     |
| FOC FLUX REGULATOR .....     | 140     |
| FREQUENCY OUTPUT .....       | 147     |
| FUNCTIONING TIMES .....      | 69      |

**I**

|                             |          |
|-----------------------------|----------|
| I/O OPTIONAL BOARD .....    | 250; 305 |
| IFD .....                   | 42; 263  |
| INPUTS FOR REFERENCES ..... | 105      |
| IPEAK .....                 | 296      |

**J**

|                 |     |
|-----------------|-----|
| JOG .....       | 121 |
| JOG INPUT ..... | 330 |

**K**

|                         |     |
|-------------------------|-----|
| KEYPAD .....            | 85  |
| KEYPAD LOCK INPUT ..... | 332 |

**L**

|                     |         |
|---------------------|---------|
| LANGUAGE .....      | 79      |
| LEDS .....          | 27      |
| LIMITS .....        | 296     |
| LOC/REM .....       | 26; 306 |
| LOC/REM INPUT ..... | 335     |
| LOCAL MODE .....    | 86      |

**M**

|                                     |            |
|-------------------------------------|------------|
| MAIN SPEED/TORQUE REFERENCE .....   | 29         |
| MAINTENANCE .....                   | 382        |
| MAXIMUM OUTPUT FREQUENCY .....      | 81         |
| MDI MULTIPROGRAMMING ENABLE .....   | 336        |
| MENU TREE .....                     | 19         |
| METHOD OF ZIEGLER AND NICHOLS ..... | 171        |
| MOTOR CONTROL .....                 | 263        |
| MOTOR SEL INPUT .....               | 332        |
| MOTOR THERMAL PROTECTION .....      | 30; 375    |
| MOTOR TUNE .....                    | 42; 44; 47 |
| MPL .....                           | 226        |
| MULTIMOTOR .....                    | 30         |
| MULTIRAMP INPUTS .....              | 329        |
| MULTISPEED .....                    | 124        |

MULTISPEED INPUTS ..... 326; 338

**N**

NAVIGATION ..... 21

**O**

OPERATION TIME COUNTER ..... 70

OUTPUT FREQUENCY ..... 260

**P**

PARAMETER MODIFICATION ..... 22

PASSWORD ..... 16; 83

PID CONFIGURATION ..... 383

PID DISABLE INPUT ..... 331

PID FEEDBACK REFERENCE ..... 29

PID PARAMETERS ..... 170

PID REFERENCE ..... 29

PID UP/DOWN RESET INPUT ..... 334

PID/PID2 UNITS OF MEASURE ..... 89

PID2 PARAMETERS ..... 185

PIPE FILL ..... 235

POWER DOWN ..... 30; 361

POWER OFF LIST ..... 77

PROFIDRIVE ..... 427

PROHIBIT SPEEDS ..... 31; 127; 130

PT100 ..... 68; 221

PTC ..... 376

**R**

REAL TIME CLOCK (RTC) ..... 401

REFERENCE FROM ENCODER ..... 39; 343

REFERENCE VARIATION PERCENT ..... 127; 132

REMOTE/LOCAL ..... 306

RESET ..... 317

RESET UP/DOWN INPUT ..... 328

RESISTOR BRAKING ..... 3; 347

REVERSE B INPUT ..... 323

REVERSE INPUT ..... 322

ROOT PAGE ..... 85

ROUNDING OFF ..... 95

**S**

S RAMPS ..... 94

SERIAL LINKS ..... 414

SERIAL NUMBER ..... 82

SLAVE INPUT ..... 330

SLIP COMPENSATION ..... 30

SOURCE SELECTION INPUT ..... 334

SPEED LOOP ..... 134

SPEED RAMPS ..... 93

SPEED REGULATOR ..... 48

SPEED SEARCHING ..... 30; 367

SPEED VAR. INPUTS ..... 333

SPEED/TORQUE LIMIT REFERENCE ..... 29

SPEED/TORQUE REFERENCE SOURCES ..... 303

START ..... 314

START B INPUT ..... 321

START INPUT ..... 320

START-UP ..... 40

STATE LIST ..... 460

STOP B INPUT ..... 322

STOP INPUT ..... 321

STOP MODE ..... 337

SUPPLY TIME COUNTER ..... 70

SW VERSIONS ..... 81

**T**

TIMERS ..... 162

TORQUE CONTROL ..... 264; 269; 274

TORQUE LIMIT SOURCE ..... 306

TORQUE LIMIT SOURCE REF. DISABLE INPUT ..... 337

TORQUE RAMPS ..... 96

TYPE OF LOC/REM CONTACT ..... 335

**U**

UP AND DOWN INPUTS ..... 327

UP/DOWN ..... 121

USER LEVEL ..... 83

**V**

VIRTUAL DIGITAL OUTPUTS ..... 226

VOLTAGE/FREQUENCY PATTERN ..... 30; 266

VTC ..... 2; 3; 44; 263

VTC CURRENT CONTROLLER ..... 143

VTC CURRENT REGULATOR ..... 142; 143

**W**

WARNING LIST ..... 459

WATCHDOG ..... 414

**X**

XAIN4 ..... 250

XAIN5 ..... 250